Operation Manual

TH7105/7110/7120
Programmable AC Power Source
V1.0.6@2019.6

Tonghui Electronic Co.,Ltd.

www.tonghui.com.cn

Contents

Chapter 1 Introduction	1
1.1 Introduction of the Instrument	1
1.2 Working Condition.....	2
1.2.1 Power Connection ✂	2
1.2.2 Environment Temperature and humidity.....	2
1.2.3 Precautions for usage	2
1.2.4 Warm-up.....	3
1.3 Safety and Symbols.....	3
1.3.1 Signs and Symbols	3
1.3.2 Laws and regulations	4
Chapter 2 Introduction.....	5
2.1 Introduction to Front Panel	5
2.2 Introduction to Rear Panel	5
2.3 Display Zoon	6
2.4 Basic Operation	7
2.4.1 Manual mode	7
2.4.1 Programmable Mode.....	8
2.5 Boot Instructions	8
Chapter 3 Basic Operations and Description.....	10
3.1 <Measurement Display>.....	10
3.1.1 Pending measurement status.....	10
3.1.2 Test Status Instruction.....	15
3.2 <MANU SETUP>	17
3.2.1 Memory Setting.....	17
3.2.2 Common Setting.....	20
3.3 <Programmable Mode>.....	24
3.3.1 Sequence Setting	24
3.3.2 Common Setting	33
3.4 <System Setting>	37

3.4.1	System Environment.....	37
3.4.2	System Communication.....	39
3.4.3	System Tool	41
Chapter 4 File Management.....		43
4.1	Internal File.....	43
4.1.1	Description.....	43
4.1.2	Operation.....	43
4.2	External File	44
4.2.1	Description.....	44
4.2.2	Operation.....	45
Chapter 5 Function Introduction.....		47
5.1	Function Structure Introduction.....	47
5.2	Programmable Mode Output Function	48
5.3	Surge Drop Function	50
5.4	Dimmer Mode Function	52
5.5	Result Display Function	53
5.6	Protection Function	55
5.7	Remote Signal Output Function	56
5.8	Remote Control Function	57
Chapter 6 Communication Interface.....		59
6.1	RS232 Interface.....	59
6.1.1	Description.....	59
6.1.2	Operation.....	60
6.2	USB Virtual Serial Port	61
6.2.1	Description.....	61
6.2.2	Driver Installation	61
6.3	SCPI Communication Commands	62
6.3.1	Command Types	62
6.3.2	Command Syntax.....	63
6.3.3	Common Commands	65

6.3.4	DISPlay Subsystem Commands.....	66
6.3.5	:FUNCTion Subsystem Commands	67
6.3.6	FETCH Subsystem Commands	89
6.3.7	SYSTem Subsystem Commands	91
6.4	MODBUS Communication Commands	97
6.4.1	MODBUS Protocol	97
6.4.2	MODBUS Write Commands.....	99
6.4.3	MODBUS Read Commands.....	131
Chapter 7 Technical Specifications.....		166
7.1	Product Specifications	166
7.1.1	AC Input	166
7.1.2	AC Output	166
7.1.3	Setup.....	166
7.1.4	Measurement	167
7.1.5	Convention	167
7.1.6	Dimension.....	168
7.2	Supplementary features.....	168
Chapter 8 Warranty.....		169
Chapter 9 Appendix.....		170
9.1	Error Message.....	170
9.2	SCPI Commands.....	170
9.2.1	DISP Commands.....	170
9.2.2	FUNC Commands.....	171
9.2.3	SYST Commands	177
9.2.4	FETCH Commands.....	178
9.3	MODBUS Commands.....	178
9.4	Manual Amendment Description	182

Declaration

The descriptions contained in this manual may not cover all information about this instrument. Introductions to the improvements of the instrument in performance, function, internal structure, outer appearance, accessories, packing material, etc. are subject to change without notice. If you find any inconformity of this manual with our instruments, please contact us for further consultation by the address listed on the cover.

Chapter 1 Introduction

Thank you for purchasing and using of our products. If you have questions after reading this manual, please contact your local distributor or call our company's engineers directly for further consultation.

1.1 Introduction of the Instrument

TH7100 series is a family of single-phased programmable AC power supply which is able to simulate a variety of normal and abnormal AC input conditions, and do the measurement of some important parameters. The main features and benefits of the instrument are listed below:

- 24-bit color, 4.3-inch LCD display
- Chinese and English operating interface
- Support output switch control
- Voltage (V), Current (I), Power (P), Peak Current (A_p), Crest Factor (CF), and Power Factor (PF) can be displayed simultaneously
- Starting phase angle ($0\sim359^\circ$), ending phase angle ($0\sim359^\circ$)
- Support surge/drop, and dimming mode function
- Support front and rear panel output
- Memory capacity
Manual mode: 50 sets
Programmable mode: 50 sets, 9 steps/set
- Intelligent temperature-controlled fan, two stages fan speed
- Start up with user's setting
- Support timing function
- Support RS232 (SCPI and MODBUS protocol), and USB COM.
- Support remote signal output function (PASS、FAIL、PROCESSING)
- Support remote control input function (includes output switch and input control of 7 memory groups)
- Support over setting current protection (HI-A), over voltage protection (OVP), low-voltage protection (LVP), over current protection (OCP), over power protection (OPP), over temperature protection (OTP)

Th7100 series single-phase programmable AC power supply includes the following models:

Model	Voltage	Current	Power
TH7105	300V	4.2A	500W
TH7110	300V	8.4A	1000W
TH7120	300V	16.8A	2000W

Table 1-1 Main Parameters of Various Models

1.2 Working Condition

1.2.1 Power Connection

- 1) Power supply: 100~120Vac or 198~242Vac
- 2) Power supply frequencies: 47~63Hz
- 3) Power range: $\geq 80\text{VA}$
- 4) The power input line L, zero-line N and ground-line E should be the same as the power plug of this instrument. Remove the protection cover on the rear panel before use of the instrument, the detailed wire connection diagram is shown in figure 1-1:

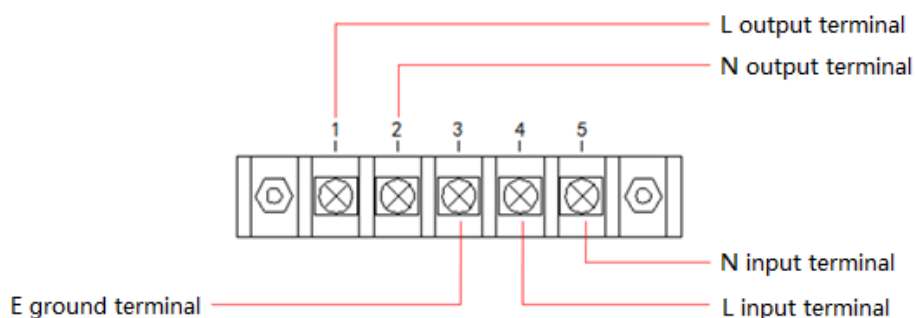

Figure 1-1

1.2.2 Environment Temperature and humidity

TH7100 series programmable AC power supply is only allowed to be used indoors and in low-condensation areas. The general environmental requirements of this instrument are shown in table 1-2. The fan speed changes intelligently with the radiator temperature. When the radiator temperature reaches 60 °C, the fan accelerates. When the radiator temperature reaches 130 °C, the instrument shuts off the output.

Environment Condition	Requirements
Operating Temperature	0°C~40°C
Operating Humidity	20%~80% (non-condensation)
Storage Temperature	-20°C~70°C
Operating Altitude	$\leq 2000\text{m}$
Pollution	Pollution level2
Safety	Safety class II

Figure 1-2

1.2.3 Precautions for usage

- 1) Please do not use the tester in dusty, vibrative, direct sunlight and corrosive gases and other adverse environments.







- 2) Please do not use damaged equipment. Before use of the instrument, please check if there are any cracks on the shell.
- 3) Please connect the device with the provided cable. Before operating the instrument, make sure the AC power supply is well grounded.
- 4) Before connecting to the device, check all the security labels on the device.
- 5) Please use wire with rated load. The capacity of all load wires must be able to withstand the maximum short-circuit output current of the power supply without overheating. If there are multiple loads, each pair of load wires must be able to safely carry the full load rated short-circuit output current of the power supply.
- 6) Please do not install replacement parts or make any unauthorized modification of the instrument.
- 7) Please do not use the device when the cover is removed or loose.
- 8) It is strictly prohibited to use this instrument on life support system or any other equipment with safety requirements.
- 9) Keep the instrument well ventilated to avoid overheating. Do not block the ventilation hole of the equipment to avoid internal temperature rising affecting the accuracy.
- 10) Please use dry cloth to clean the shell of the equipment. Do not clean the inside of the instrument.
- 11) Please do not switch the instrument frequently to avoid loss of stored data.
- 12) The instrument has been carefully designed to reduce clutter due to AC power input. However, it should still be used under low noise conditions. If that is inevitable, please install the power filter.
- 13) When the instrument is not used for a long time, please put it in the original box or similar box and stored in a ventilated room with temperature of 5°C~40°C and relative humidity less than 85% RH. Do not store the instrument in a corrosive atmosphere containing harmful impurities and should avoid direct sunlight.

1.2.4 Warm-up

For accurate measurement, the warm-up time should not be less than 30 minutes.

1.3 Safety and Symbols

1.3.1 Signs and Symbols

	ON (power switch closed)		Protective grounding terminal
	OFF (power switch open)		Ground terminal
	Warning sign		Power line ground

	Shock hazard sign		
---	-------------------	--	--

Table 1-3

1.3.2 Laws and regulations



CE label indicates that the instrument complies with all relevant European laws (a year indicates the year in which the design was approved).

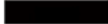

 This device complies with the marking requirements of WEEE directive (2002/96/EC), and this additional product label states that this appliance/electronic product should not be discarded in household waste. According to the WEEE directive annex I classification of the equipment, the instrument belongs to “monitor” products.

Chapter 2 Introduction

The content of this chapter is just a general description. It mainly introduces the front and rear panel, display area, boot interface and basic operation. Please refer to chapter 3 for detailed introduction.

2.1 Introduction to Front Panel

TH7100 series programmable AC power supply front panel is shown in figure 2-1.

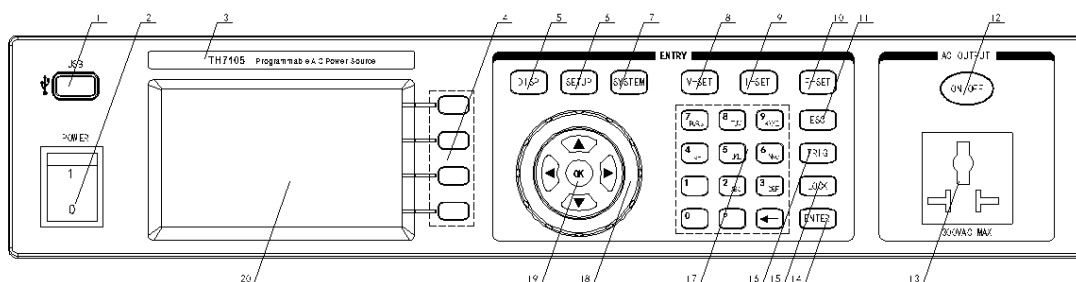

Figure 2-1 Front panel

Index	Name	Function
1	U disc interface	Read or store data
2	Power switch	Power switch
3	Trademark and models	Instrument trademark and models
4	Function buttons	Screen-labeled function keys
5	DISP	Quickly switch to measurement display page
6	SETUP	Quickly switch to measurement setting page
7	SYSTEM	Quickly switch to system setting page
8	V-SET	Voltage setting
9	I-SET	Current setting
10	F-SET	Frequency setting
11	ESC	Exit or cancel
12	ON/OFF	Output switch
13	Power Output Socket	Power output Socket
14	ENTER	Enter button
15	LOCK	Keyboard lock button
16	TRIG	Surge/drop manual trigger button
17	Number pad and delete button	Number input and delete
18	knob	Adjust the setting value or move the cursor
19	Arrow key and OK button	Move the cursor and enter
20	LCD display	Screen display

2.2 Introduction to Rear Panel

TH7100 series programmable AC power supply rear panel is shown in figure 2-2.

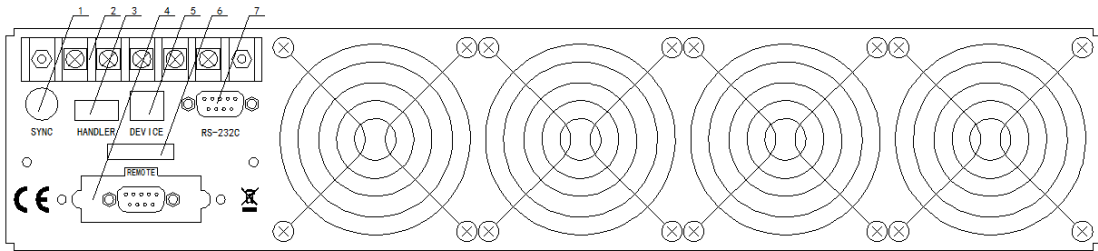

Figure 2-2

Index	Name	Function
1	Synchronism Signal Socket	When output is enabled, it will output a 10V voltage signal from the socket at the same time.
2	Power Input Output	Power terminal and power output terminal
3	Signal Output Terminal	Output signals of PASS, FAIL, and PROCESSING for automation devices.
4	Remote Control interface	Control output switches, and choose to execute memory groups M1, M2 to M7.
5	USB COM Interface	Through this port, TH7100 series instrument can be controlled by external controller, and realize online communication with computer
6	Nameplate	Production date, instrument number, manufacturer.
7	RS232 Serial Interface	RS232 serial communication interface, used for online communication with computer.

2.3 Display Zoon

The TH7100 series programmable ac power supply has a 24-bit color 4.3-inch color LCD screen with a resolution of 480×272. The content displayed on the screen is shown in figure 2-3.

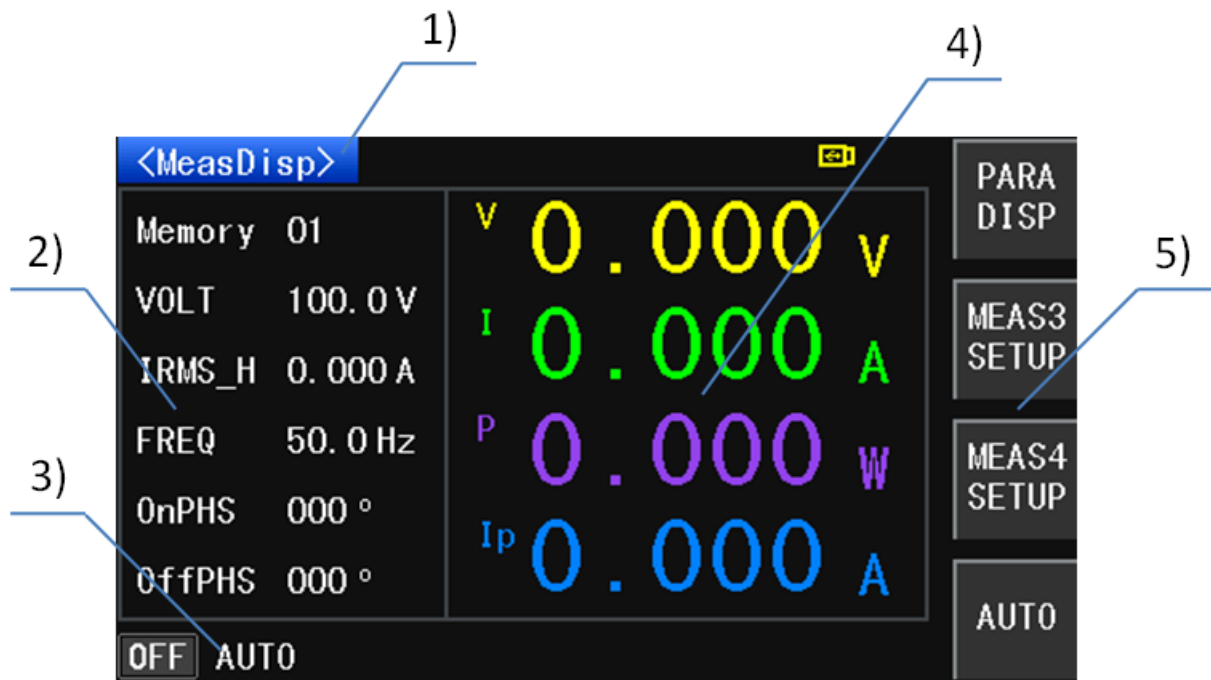

Figure 2-3 display description

1) Main menu zone

This area indicates the name of the current page

2) Parameters setup zone

This area is used to modify the test parameters

3) Status zone

This area is used to display various prompt information and various status information during system testing.

4) Measurement result display zone

This area shows the parameter results of the test. The parameter display 1 indicates the output voltage value, the parameter display 2 indicates the output current value, the parameter display 3 indicates the output power value, and the parameter display 4 indicates the peak current value.

5) Soft key zone

This area is used to display the function menu corresponding to the cursor area.

2.4 Basic Operation

2.4.1 Manual mode

- 1) Set the output mode: Press the **SETUP** button, then press the **MANU SETUP** function button.
- 2) Set the voltage output mode: Make use of the direction key to move the cursor to the V mode, and then use the soft key to select AUTO or HIGH voltage.
- 3) Set the output voltage: Press the direction key **▲** or **▼** to move the cursor to VOLT setting, and set the output voltage by the numeric keys and **ENTER** key.
- 4) Set the output frequency: Press the direction key **▲** or **▼** to move the cursor to FREQ setting, and set the

output frequency by the numeric keys and **ENTER** key.

5) Test output: Press the **DISP** button, then press the **ON/OFF** button to output.

2.4.1 Programmable Mode

1) Set the output mode: press the **SETUP** key, then press the **PROG SETUP** function key

2) Set the sequence setting parameters: Press the direction key **▲** or **▼** to move the cursor to set the parameters such as set voltage, voltage mode, frequency, step connection, delay time, dwell time and so on.

3) Setting steps: Press the arrow keys **▲** or **▼** to move the cursor to the parameter step. Use the numeric keys and the **ENTER** key to set the step number, then follow step 2) to set the parameters under the step number.

4) Repeat steps 2) and 3) to set the required steps.

5) Test output: Press the **DISP** button, then press the **ON/OFF** button to output.

2.5 Boot Instructions

Press the power switch in the lower left corner of the front panel of the instrument to turn the instrument on and display the boot screen. Figure 2-4 shows the boot screen of the TH7100 series programmable AC power supply. The boot screen includes some product information such as the trademark, instrument model and software version number of Tonghui Company.

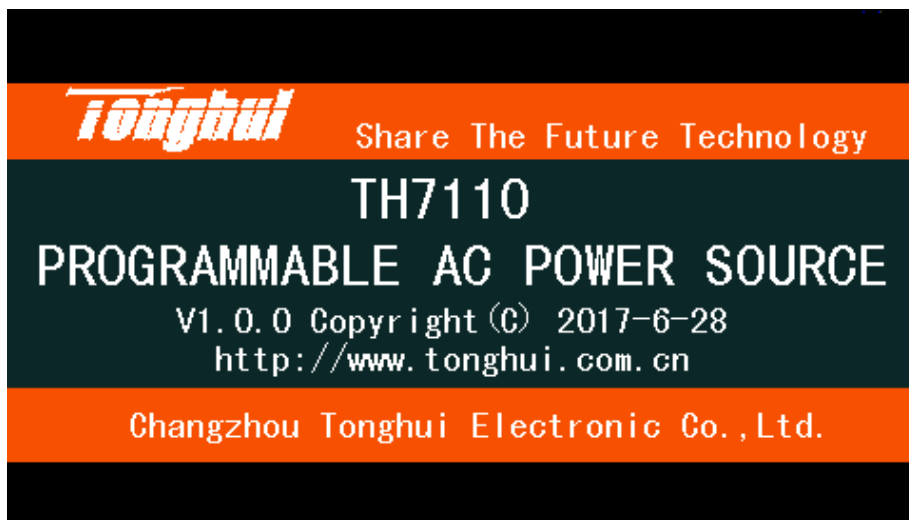
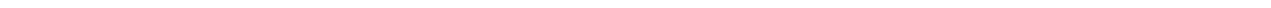

Figure 2-4 Start Up Screen

If the user has turned on the password protection function, then the instrument will request to enter the power-on password. Enter the power-on password according to the screen display. This series of products is not set with the power-on password when leaving the factory, users can reset the power-on password according to their needs during use. For details, see Password on the <System Settings> page.



Chapter 3 Basic Operations and Description

This chapter mainly introduces the description and operation of the setting parameters under the <Measurement Display> page, the description and operation of the soft key area buttons, and the description of the status area; Description and operation of setting parameters under <Manual mode> page; Description and operation of setting parameters under <Programmable mode> page; Description and operation of parameters under <System setting> page; Description and operation under <Internal file>, <External file> page.

3.1 <Measurement Display>

3.1.1 Pending measurement status

Press the **DISP** menu button, when the test mode is manual mode, the <Measurement Display> page is shown in Figure 3-1:

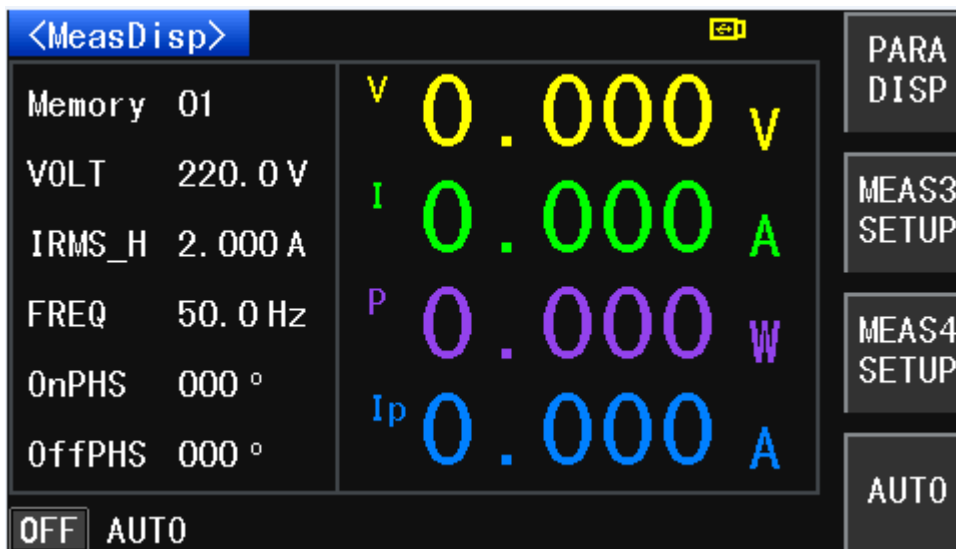

Figure 3-1 Manual mode <measurement display> page

When the test mode is programmable, the <Measurement Display> page is shown in Figure 3-2:

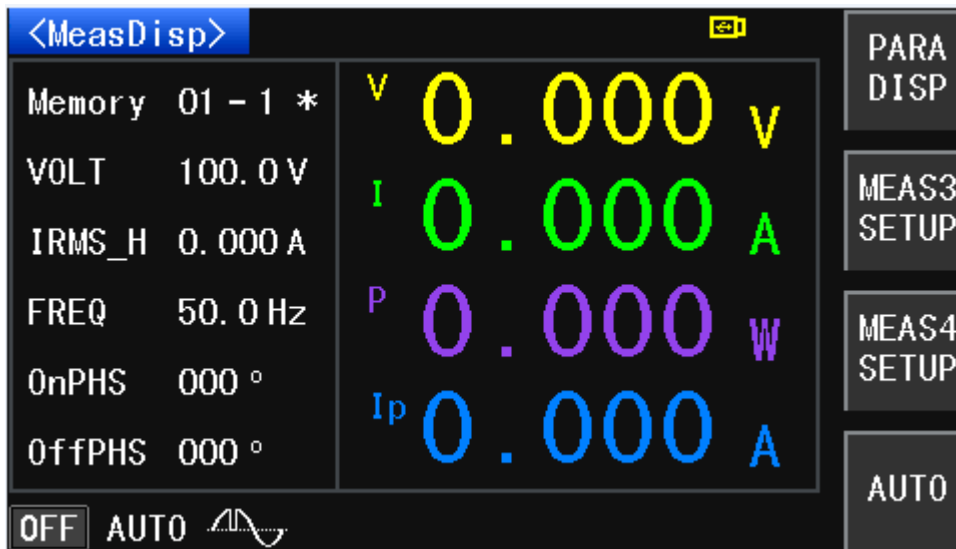

Figure 3-2 Programmable Mode <Measurement Display> page

3.1.1.1 Parameter setting description and operation

■ Memory

1) Description

In manual mode, this parameter value indicates memory group number, and there are 1~50 memory groups in total. In the programmable mode, the first number indicates the memory group number, and there are 1~50 memory groups in total; The second value indicates the step number, a total of 1 to 9 steps. The * after the value indicates that the step connection is turned on. If there is no * after this value, the step connection is turned off.

2) Operation

Press the ▼ key or **knob** to move the cursor to this parameter option, change the value via the front panel numeric keys, then press **ENTER** or **OK** to confirm. When changing the value with the numeric keys, if you do not want to change the parameter value or press the wrong numeric key, you can cancel it by pressing **←** key or **ESC** key.

■ Voltage (VOLT)

1) Description

This parameter represents the output voltage setting, and the voltage setting range is 0.0~300.0V. In manual mode, this parameter can be quickly changed by V-SET button. In programmable mode measurement display page, this parameter cannot be changed.

2) Operation

Press the ▼ key or **knob** to move the cursor to this parameter option, change the value by front panel numeric keys, then press **ENTER** or **OK** button to confirm. When changing the value with the numeric keys, if you do not want to change the parameter value or press the wrong numeric key, you can cancel it by pressing the **←** key or **ESC** key.

■ Current (IRMS_H)

1) Description

This parameter represents the current upper limit setting. When the setting voltage is not greater than 150V, the range is 0.000~8.400A; When the setting voltage is greater than 150V, the setting range is 0.000~4.200A. When set to 0.000, the current upper limit function is turned off. In manual mode, this parameter can be changed quickly by **I-SET** button. This parameter cannot be changed under the programmable mode measurement display page.

2) Operation

Press the **▼** key or **knob** to move the cursor to this parameter option, change the value via the front panel numeric keys, then press **ENTER** or **OK** to confirm. When changing the value with the numeric keys, if you do not want to change the parameter value or press the wrong numeric key, you can cancel it by pressing the **←** key or **ESC** key.

■ Frequency (FREQ)

1) Description

This parameter represents the output frequency setting, and its setting range is 45.0~500Hz. In manual mode, this parameter can be changed quickly by F-SET button. This parameter cannot be changed under the programmable mode measurement display page.

2) Operation

Press the **▼** key or **knob** to move the cursor to this parameter option, change the value via the front panel numeric keys, then press **ENTER** or **OK** to confirm. When changing the value with the numeric keys, if you do not want to change the parameter value or press the wrong number key, you can cancel it by pressing the **←** key or **ESC** key.

■ Initial Phase Angle (ONPHS)

1) Description

This parameter represents the initial phase angle of the output waveform and ranges from 0 to 359° . This parameter cannot be changed under the programmable mode measurement display page.

2) Operation







Press the **▼** key or **knob** to move the cursor to this parameter option, change the value via the front panel numeric keys, then press **ENTER** or **OK** to confirm. When changing the value with the numeric keys, if you do not want to change the parameter value or press the wrong numeric key, you can cancel it by pressing the **←** key or **ESC** key.

■ Ending Phase Angle(OFFPHS)

1) Description

This parameter represents the ending phase angle of the output waveform, which ranges from 0 to 359° . This parameter cannot be changed under the programmable mode measurement display page.

2) Operation

Press the  key or  to move the cursor to this parameter option, change the value via the front panel numeric keys, then press  or  to confirm. When changing the value with the numeric keys, if you do not want to change the parameter value or press the wrong numeric key, you can cancel it by pressing the  key or  key.

3.1.1.2 Soft keypad description and operation

■ Parameter Display (PARA DISP)

1) Description

This softkey is used to switch the output parameter display. As shown in Figure 3-3:



Figure 3-3

2) Operation

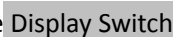
Under the <Measurement Display> page, press the  button of the soft key area to switch the output parameter display.

■ MESA3 SETUP

1) Description

This soft-key is used to configure the parameters required for MESA3, press this soft-key to select the power (PWR)、peak current (APK)、power factor (PF)、crest factor (CF). Please refer to figure 3-4

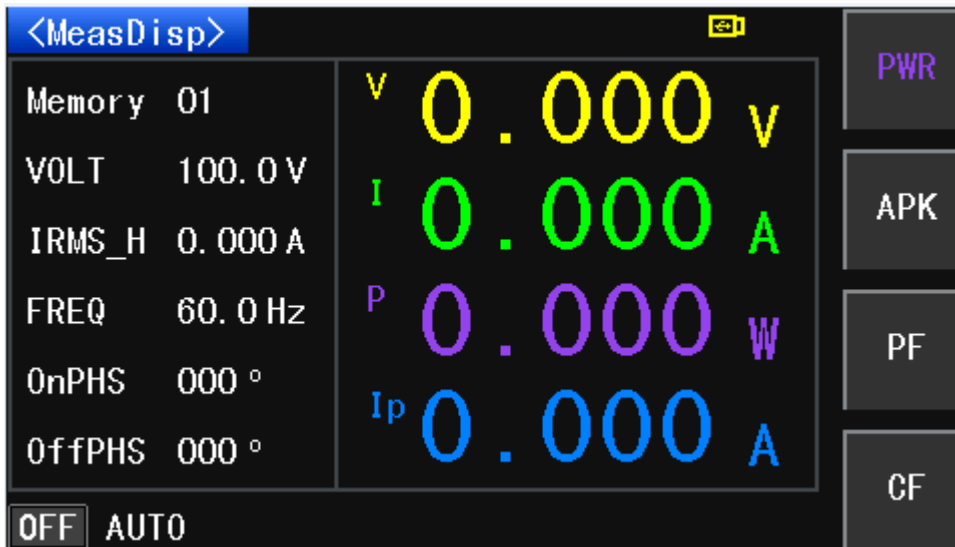

Figure 3-4 MESA3 Key

2) Operation

Under the <Measurement Display> page, press the MESA3 key of the soft key area, then press the PWR or APK or PF or CF as needed to switch output parameters of MESA 3.

■ MESA4 SETUP

1) Description

This soft-key is used to configure the parameters required for MESA4, press this soft-key to select the power (PWR)、peak current (APK)、power factor (PF)、crest factor (CF). Please refer to figure 3-5.

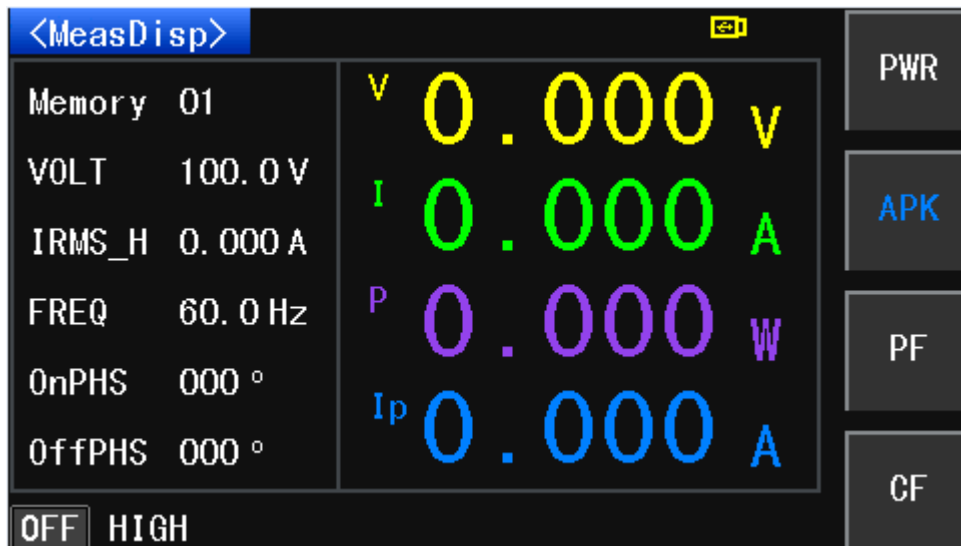

Figure 3-5 MESA4 Key

2) Operation

Press the key or knob to move the cursor to this parameter option, the soft-key zone displays the function menu for this parameter, which can be changed by turning the soft-key ON or OFF.

■ AUTO

1) Description

This key is the voltage mode setting key, which can be set to “AUTO” or “HIGH”. When the voltage mode is set to “AUTO”, it will automatically judge whether the voltage is high or low based on the setting voltage. When the voltage mode is set to “HIGH”, the voltage will be set to HIGH (i.e. the range of 0~300V).

2) Operation

In <Measurement Display> page, press AUTO soft key to switch between “AUTO” and “HIGH”.

3.1.1.3 State Zoon Description

- OFF: Output is not enabled
- AUTO: Voltage mode is in “AUTO”
- : Surge/drop function is enabled

3.1.2 Test Status Instruction

In <MeasDisp> page, press **ON/OFF** button to enable output. When the test mode is in MANU SETUP mode, the <MeasDisp> page is shown in figure 3-6:



Figure 3-6 MANU SETUP Mode <MeasDisp> Page

When the test mode is in PROG SETUP, the <MeasDisp> page is shown in figure 3-7:



Figure 3-7 PROG SETUP Mode <MeasDisp> Page

3.1.2.1 Soft key Instruction and Operation

■ PARA DISP

1) Description

This soft key is used to switch display of output parameters. When pressed, all output parameters are displayed.

2) Operation

Under <MeasDisp> page, press the PARA DISP soft key to switch the display of output parameters.

■ AUTO

1) Description

This key is the voltage mode setting key, which can be set to "AUTO" or "HIGH". When the voltage mode is set to "AUTO", it will automatically judge whether the voltage is high or low based on the setting voltage. When the voltage mode is set to "HIGH", the voltage will be set to HIGH (i.e. the range of 0~300V).

2) Operation

In <Measurement Display> page, press AUTO soft key to switch between "AUTO" and "HIGH"

■ DATA HOLD

1) Description

This key keeps the output constant.

2) Operation

Under <MeasDisp> page, press DATA HOLD soft key to keep output constant. Press this key again, the output will change according to real situation.

3.1.2.2 State Zoon Description

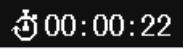
- ON: Output is enabled
- AUTO: Voltage mode is in “AUTO”, it will automatically judge whether the voltage is high or low based on the setting voltage.
- : Surge/drop function is enabled. The icon turns green when the instrument is testing.
-  00:00:22: It indicates the testing time. If the time is set, the time will countdown, and when it reaches 00:00:00, the output will be disabled automatically.

3.2 <MANU SETUP>

3.2.1 Memory Setting

3.2.1.1 Description and Operation

1) Description

In MANU SETUP mode, the instrument is a pure power supply, users are able to set memory sequence, voltage, voltage mode, frequency, current upper limit, current lower limit, SD voltage, SD site, SD time, SD Connection and other parameters show in figure 3-8:

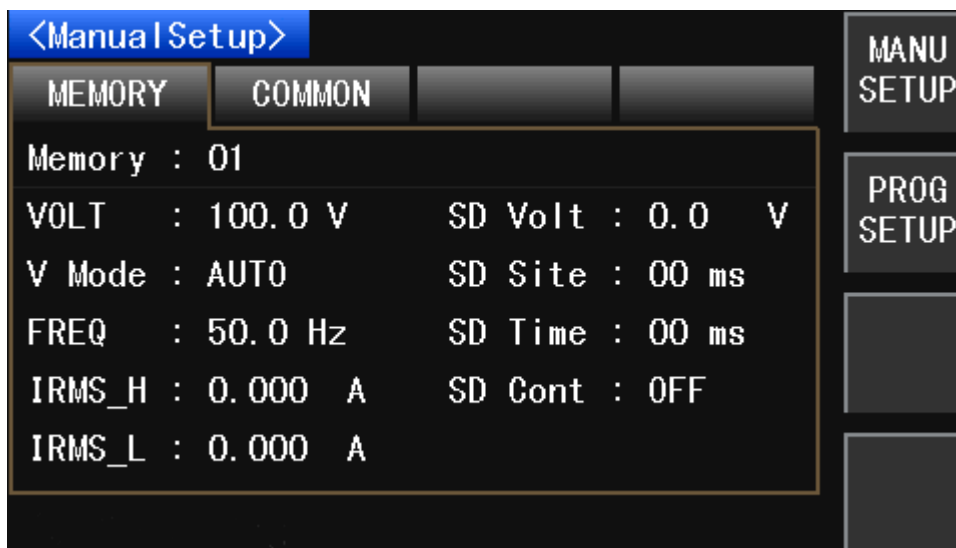

Figure 3-8

2) Operation

Press **SETUP** button in the front panel, then press MANU SETUP soft key to enter Memory setting page. Make use of the knob or arrow buttons to move the cursor to the desired place and do the parameter setting.

3.2.1.2 Parameter Setting Instruction and Operation

■ Memory

1) Description

In manual mode, this parameter value indicates memory group number, and there are 1~50 memory groups in total.

3) Operation

Press the **▼** key or **knob** to move the cursor to this parameter option, change the value via the front panel numeric keys, then press **ENTER** or **OK** to confirm. When changing the value with the numeric keys, if you do not want to change the parameter value or press the wrong numeric key, you can cancel it by pressing **←** key or **ESC** key.

■ Voltage (VOLT)

1) Description

This parameter represents the output voltage setting, and the voltage setting range is 0.0~300.0V.

3) Operation

Press the **▼** key or **knob** to move the cursor to this parameter option, change the value by front panel numeric keys, then press **ENTER** or **OK** button to confirm. When changing the value with the numeric keys, if you do not want to change the parameter value or press the wrong numeric key, you can cancel it by pressing the **←** key or **ESC** key.

■ Voltage Mode (V-Mode)

1) Description

This parameter is used to set the voltage output mode, which can be set to "AUTO" or "HIGH". When the voltage mode is set to "AUTO", the set voltage value will automatically determine whether the voltage is high (i.e. the range of 150.1~300V) or low (i.e. the range of 0~150V). When the voltage mode is set to "HIGH", the voltage will be set to HIGH (i.e. the range of 0~300V).

4) Operation







Press the **▼** key or **knob** to move the cursor to this parameter option, change the value with soft keys.

■ Frequency (FREQ)

1) Description

This parameter is used to set output frequency, and its setting range is 45.0~500Hz. When the frequency is less than 100Hz, the resolution is 0.1Hz. When the frequency is greater or equal to 100Hz, the resolution is 1Hz.

2) Operation







Press the  key or  to move the cursor to this parameter option, change the value via the front panel numeric keys, then press  or  to confirm. If you do not want to change the parameter value or press the wrong numeric keys, you can cancel it by pressing the  key or  key.

■ Current Upper Limit(IRMS_H)

1) Description

This parameter is used to set current upper limit. When the setting voltage is not greater than 150V, the range is 0.000~8.400A; When the setting voltage is greater than 150V, the setting range is 0.000~4.200A. When set to 0.000, the current upper limit function is turned off. When output current is greater than 0.000, there will be an alarm, "HI-A" will be displayed, and output will be turned off.

2) Operation







Make use of  key or the  to move the cursor to this parameter option, change the value via the front panel numeric keys, then press  or  to confirm. If you do not want to change the parameter value or press the wrong numeric key, you can cancel it by pressing the  key or  key.

■ Current lower Limit(IRMS_L)

1) Description

This parameter is used to set current lower limit. When the setting voltage is not greater than 150V, the range is 0.000~8.400A; When the setting voltage is greater than 150V, the setting range is 0.000~4.200A. When the "PLC ONoff" is turned on which is accessed from <SysSetup> then "SysCom", and output current is not less than current lower limit, "PASS" will be displayed while the output is completed.

2) Operation







Make use of  key or the  to move the cursor to this parameter option, change the value via the front panel numeric keys, then press  or  to confirm. If you do not want to change the parameter value or press the wrong numeric key, you can cancel it by pressing the  key or  key.

■ SD Volt

1) Description

This parameter is used to set surge/drop, and its setting range is 0.0~300V. When the parameter value is greater than the setting voltage, it is a surge wave, when it is less than the setting voltage, it is a drop wave. This parameter will be displayed when the Surge/Drop option from COMMON page under <Setup> page is turned on. For details, please refer to Surge/Drop function instruction.

2) Operation







Make use of  key or the  to move the cursor to this parameter option, change the value via the front panel numeric keys, then press  or  to confirm. If you do not want to change the parameter value or press the wrong numeric key, you can cancel it by pressing the  key or  key.

■ SD Site

1) Description

This parameter represents the position where the Surge/Drop appears, which can be calculated by the time between this position and the 0 phase point. This parameter is displayed when the Surge/Drop option in <Setup> COMMON page is turned on. When the “SD Cont” is turned on, the range is 0~20ms. When “SD Cont” is turned off, the range is 0~99ms. For details, please refer to Surge/Drop function instruction.

2) Operation







Make use of  key or the  to move the cursor to this parameter option, change the value via the front panel numeric keys, then press  or  to confirm. If you do not want to change the parameter value or press the wrong numeric key, you can cancel it by pressing the  key or  key.

■ SD Time

1) Description



This parameter indicates the waveform width of the surge or drop. This parameter is displayed when the Surge/Drop option in <Setup> COMMON page is turned on. When the parameter SD connection (SD Cont) is turned on, its setting range is 0~20ms; when the parameter SD connection (SD Cont) is turned off, its setting range is 0~99ms. For details, please refer to Surge/Drop function instruction.

2) Operation



Make use of  key or the  to move the cursor to this parameter option, change the value via the front panel numeric keys, then press  or  to confirm. If you do not want to change the parameter value or press the wrong numeric key, you can cancel it by pressing the  key or  key.

■ SD Cont

1) Description

This parameter indicates whether the Surge or Drop is triggered automatically or manually. When this parameter is set to “ON”, press  button, the system will execute the trigger action continuously, sending a Surge or Drop wave every 100ms. When this parameter is set to “OFF”, press  button, the instrument will execute trigger action every time when pressing  button. This parameter is displayed when the Surge/Drop option in <Setup> COMMON page is turned on. For details, please refer to Surge/Drop function instruction.

2) Operation

Make use of  key or the  to move the cursor to this parameter option, then the soft key zoon will display the corresponding function menu, change the value with soft keys.

3.2.2 Common Setting

3.2.2.1 Description and Operation

1) Description

Users can set the high voltage limit, low voltage limit, high frequency limit, low frequency limit, starting angle, ending angle, test result, surge drop, over-current fold, dimming mode, timer and other

parameters under the COMMON setting in <Setup> page. These parameter items are common to all memory sequences under the MEMORY setting. As shown in Figure 3-9:

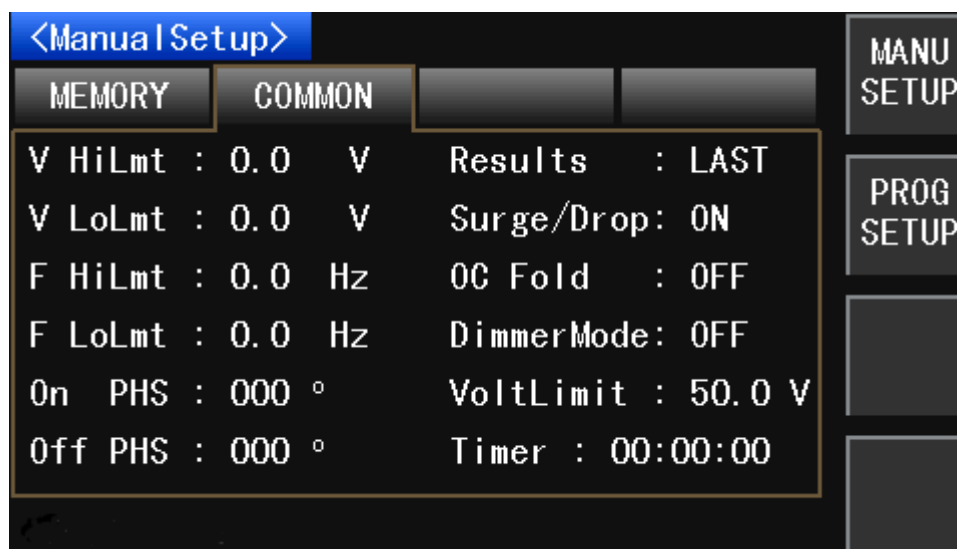

Figure3-9 General Setting<Manual Mode>

2) Operation

Press SETUP key, select <Manual Mode>, then make use of the knob and the ► button to move the cursor to the COMMON option.

3.2.2.2 Parameters Setting Description and Operation

■ V HiLmt

1) Description

This parameter is used to set the high limit of output voltage. Its range is 0.0~300.0V.

2) Operation

Make use of the ▼ key or the knob to move the cursor to this parameter option, then change it through the front panel numeric keys, then press ENTER or OK to confirm the change. If you do not want to change the parameter value or press the wrong numeric key, you can cancel it by pressing the ← key or ESC key.

■ V LoLmt

1) Description

This parameter is used to set the low limit of output voltage. Its range is 0.0~300.0V.

2) Operation







Make use of the ▼ key or the knob to move the cursor to this parameter option, then change it through the front panel numeric keys, then press ENTER or OK to confirm the change. If you do not want to change the parameter value or press the wrong numeric key, you can cancel it by pressing the ← key or ESC key.

■ F HiLmt

1) Description

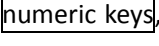
This parameter is used to set the high limit of output frequency. Its range is 45.0~500.0Hz.

2) Operation







Make use of the  key or the  to move the cursor to this parameter option, then change it through the front panel , then press  or  to confirm the change. If you do not want to change the parameter value or press the wrong numeric key, you can cancel it by pressing the  key or  key.

■ F LoLmt

1) Description

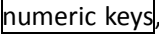
This parameter is used to set the low limit of output frequency. Its range is 45.0~500.0Hz

2) Operation







Make use of the  key or the  to move the cursor to this parameter option, then change it through the front panel , then press  or  to confirm the change. If you do not want to change the parameter value or press the wrong numeric key, you can cancel it by pressing the  key or  key.

■ On PHS

1) Description

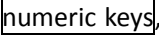
This parameter is used to set the starting phase angle of output waveform. Its range is 0~359° .

2) Operation







Make use of the  key or the  to move the cursor to this parameter option, then change it through the front panel , then press  or  to confirm the change. If you do not want to change the parameter value or press the wrong numeric key, you can cancel it by pressing the  key or  key.

■ Off PHS

1) Description

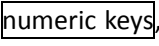
This parameter is used to set the ending phase angle of output waveform, its range is 0~359° .

2) Operation



Make use of the  key or the  to move the cursor to this parameter option, then change it through the front panel , then press  or  to confirm the change. If you do not want to change the parameter value or press the wrong numeric key, you can cancel it by pressing the  key or  key.

■ Results

1) Description

This parameter is used to set the status of the display page of the last test result, there are three modes: "LAST", "ALL" and "P/F". When set to "LAST", the display will show the final test result after the test is over; When set to "ALL", the display will show all test results after the test is over; When set to "P/F", the display will show "PASS" or "FAIL" after the test is over. In the manual mode, when the voltage output value and the frequency value are in the range of the high voltage limit, the low voltage limit, the high frequency limit, and the low frequency limit, "PASS" is displayed at the end of the test; If it is not within the range, "FAIL" is displayed, out of range is displayed, and shows the parameter values that are out of range. For details, please refer to result display function.

2) Operation



Make use of the  key or the  to move the cursor to this parameter option, the soft-key zone displays the function menu of this parameter, this parameter can be changed by the soft-key **LAST**, **ALL** or **P/F**.

■ Surge/Drop

1) Description

This parameter is used to set whether to enable the Surge/Drop function. When this parameter is set to "ON", the MEMORY page will display "SD Volt", "SD Site", "SD Time", "SD Cont"; When this parameter is set to "OFF", these parameters are not displayed. For details, please refer to Surge/Drop function.

2) Operation



Make use of the  key or the  to move the cursor to this parameter option, the soft-key zone displays the function menu for this parameter, this parameter can be changed via the soft-key **ON** or **OFF**.

■ OC Fold

1) Description

This parameter is used to set whether to enable the over-current fold function. When this parameter is set to "ON", the output voltage will decrease due to the load increased, the current output will be kept constant at current high limit. (Note: After this function is enabled, the current will output only if the output current is greater than the current high limit setting value.) When this parameter is set to "OFF", the over-current fold function is turned off.

2) Operation

Make use of the  key or the  to move the cursor to this parameter option, the soft-key zone displays the function menu of this parameter, this parameter can be changed via the soft-key **ON** or **OFF**.



■ Dimmer Mode

1) Description

This parameter is used to set the front dimmer mode or back dimmer mode. When the dimming mode is turned on, the surge/drop and SD count are enabled by default. In this mode, the manual mode MEMORY setting can only set parameters such as voltage, frequency, and SD voltage. For details, see

the dimming mode function.

2) Operation







Make use of the  key or the  to move the cursor to this parameter option, the soft-key zone displays the function menu of this parameter. This parameter can be changed to **OFF**, **Front**, or **BACK**.

■ Timer

1) Description

This parameter is used to set the output timing function. When the user sets the value of this parameter, the system will automatically shut down the output as the value countdown to 00:00:00. If the user does not set this parameter value, the time of the instrument output is displayed under the <MeasDisp> page.

2) Operation







Make use of the  key or the  to move the cursor to this parameter option, then change it with the front panel numeric keys, and finish with  or  keys to confirm the change. If you do not want to change the parameter value or press the wrong numeric key when changing with the numeric keys, you can cancel it by pressing the  key or  key.

■ VoltLiLmt

1) Description

This parameter is used to set the output voltage limit protection. This parameter is the absolute value of the difference between the output voltage and the set voltage. When the difference between real output voltage and the set voltage is lower or higher than VoltLiLmt, the output initiates over-voltage protection (OVP) or over-current protection (LVP) and the output is turned off.

2) Operation

Make use of the  key or the  to move the cursor to this parameter option, then change it with the front panel numeric keys, and finish with  or  keys to confirm the change. If you do not want to change the parameter value or press the wrong numeric key when changing with the numeric keys, you can cancel it by pressing the  key or  key.

3.3 <Programmable Mode>

3.3.1 Sequence Setting

3.3.1.1 Description and Operation

1) Description

In <ProgramSetup> MEMORY page, users can set the following parameters when the Surge/drop option in <ProgramSetup> COMMON page is turned on (figure 3-10, 3-11, and 3-12 below).

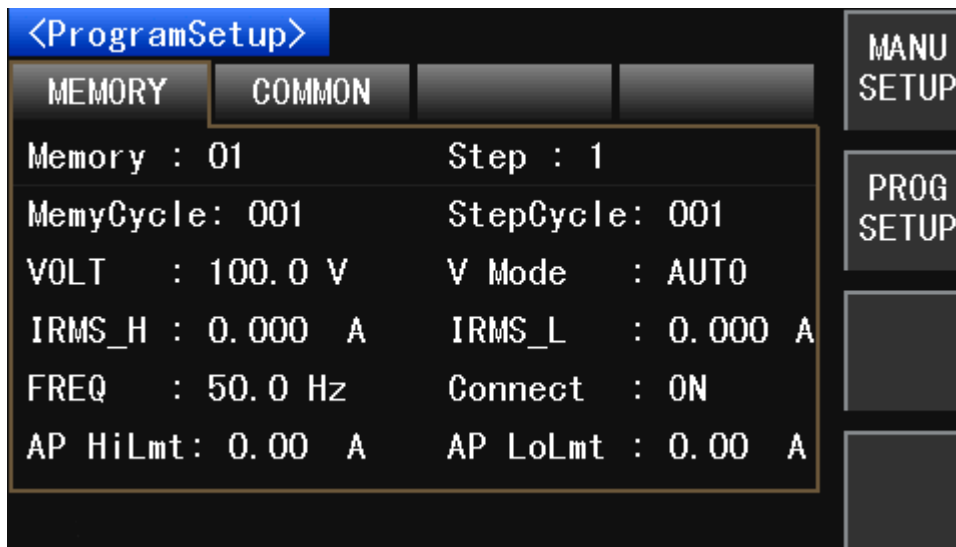

Figure 3-10 Sequence setting page 1 in <programmable mode>

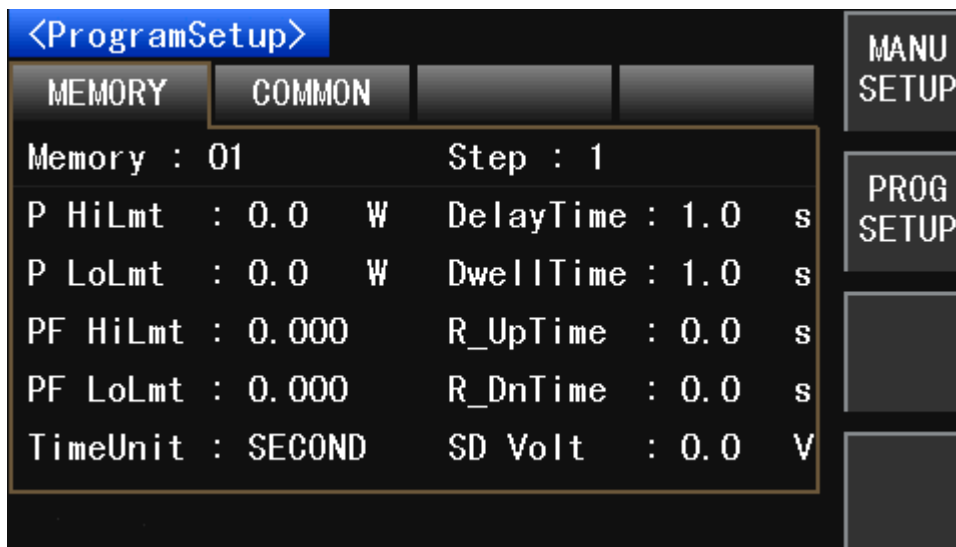

Figure 3-11 Sequence setting page 2 in <programmable mode>



Figure 3-12 Sequence setting page 3 in <programmable mode>

3) Operation

Press the **SETUP** button, then select **PROG SETUP** option. Make use of **arrow keys** or the **knob** or the **page up/page down** soft keys to switch to different pages.

3.3.1.2 Setting Parameters Description and Operation

■ Memory

1) Description

In the programmable mode, the parameter value indicates the memory group number, and there are 1~50 memory groups. See the programmable mode output function for details.

2) Operation

Make use of the **▼** key or the **knob** to move the cursor to this parameter option, then change it with the front panel numeric keys, and finish with **ENTER** or **OK** keys to confirm the change. If you do not want to change the parameter value or press the wrong numeric key when changing with the numeric keys, you can cancel it by pressing the **←** key or **ESC** key.

■ Memory Cycle

1) Description

In programmable mode, this parameter is used to set the number of cycles of the current memory setting. When this parameter is set to "000", it will keep testing until the user presses **ON/OFF** button or run into errors; when it is set to 1~999, it indicates the number of cycles of the current memory setting. See the programmable mode output function for details.

2) Operation

Make use of the **▼** key or the **knob** to move the cursor to this parameter option, then change it with the front panel numeric keys, and finish with **ENTER** or **OK** keys to confirm the change. If you do not want to change the parameter value or press the wrong numeric key when changing with the numeric keys, you can cancel it by pressing the **←** key or **ESC** key.

■ Step

1) Description

In programmable mode, this parameter represents the step number, which has 1~9 steps. See the programmable mode output function for details.

2) Operation

Make use of the **▼** key or the **knob** to move the cursor to this parameter option, then change it with the front panel numeric keys, and finish with **ENTER** or **OK** keys to confirm the change. If you do not want to change the parameter value or press the wrong numeric key when changing with the numeric keys, you can cancel it by pressing the **←** key or **ESC** key.

■ StepCycle

1) Description

In programmable mode, this parameter represents the number of cycle of the current step. When this parameter is "0", it will keep testing until the user presses the **ON/OFF** button or run into errors; When it is set to 1~999, it indicates the number of cycles of the current step. See the programmable mode output function for details.

2) Operation

Make use of the **▼** key or the **knob** to move the cursor to this parameter option, then change it with the front panel numeric keys, and finish with **ENTER** or **OK** keys to confirm the change. If you do not want to change the parameter value or press the wrong numeric key when changing with the numeric keys, you can cancel it by pressing the **←** key or **ESC** key.

■ VOLT

1) Description

This parameter is used to set the output voltage. The range is 0.0~300V.

2) Operation

Make use of the **▼** key or the **knob** to move the cursor to this parameter option, then change it with the front panel numeric keys, and finish with **ENTER** or **OK** keys to confirm the change. If you do not want to change the parameter value or press the wrong numeric key when changing with the numeric keys, you can cancel it by pressing the **←** key or **ESC** key.

■ V Mode

1) Description

This parameter is used to set the voltage output mode, and can be set to "AUTO" or "HIGH". When the voltage mode is set to "AUTO", the voltage is automatically judged according to the set voltage value to be high (i.e. 150.1~300V range) or low (i.e. 0~150V range). When the voltage mode is set to "HIGH", it means that the voltage is forced to set to high (i.e. 0 to 300V range).

2) Operation







Make use of the **▼** key or the **knob** to move the cursor to this parameter option, the soft-key area displays the function menu of this parameter. This parameter can be set to **AUTO** or **HIGH** with the corresponding soft keys.

■ IRMS_H

1) Description

The parameter represents the current upper limit setting. When the set voltage is not greater than 150V, the range is 0.000~8.400A; When the set voltage is greater than 150V, the setting range is 0.000~4.200A. When set to 0.000, the current upper limit function is turned off. When the output current is greater than this value, it will alarm and display "HI-A" and turn off the output.

2) Operation







Make use of the  key or the  to move the cursor to this parameter option, then change it with the front panel numeric keys, and finish with  or  keys to confirm the change. If you do not want to change the parameter value or press the wrong numeric key when changing with the numeric keys, you can cancel it by pressing the  key or  key.

■ IRMS_L

1) Description

The parameter represents the current lower limit setting. When the set voltage is not greater than 150V, the range is 0.000~8.400A; When the set voltage is greater than 150V, the range is 0.000~4.200A. When the "PLC Onoff" under <SysSetup> SysCom page is set to ON, and IRMS_L is not 0, if current output is less than IRMS_L, "FAIL" will be displayed after the output ends; If the output current is greater than or equal to IRMS_L, "PASS" will be displayed after the output ends. For details, see the result display function and remote control signal output function. When set to 0.000, the IRMS_L function is turned off.

2) Operation







Make use of the  key or the  to move the cursor to this parameter option, then change it with the front panel numeric keys, and finish with  or  keys to confirm the change. If you do not want to change the parameter value or press the wrong numeric key when changing with the numeric keys, you can cancel it by pressing the  key or  key.

■ FREQ

1) Description

This parameter is used to set the output frequency. The range is 45.0~500Hz. When the frequency is less than 100 Hz, the resolution is 0.1 Hz; when the frequency is not less than 100 Hz, the resolution is 1 Hz.

2) Operation

Make use of the  key or the  to move the cursor to this parameter option, then change it with the front panel numeric keys, and finish with  or  keys to confirm the change. If you do not want to change the parameter value or press the wrong numeric key when changing with the numeric keys, you can cancel it by pressing the  key or  key.



■ Connect

1) Description

This parameter is used to indicate whether the current step is connected to the current memory sequence. When the step connection of the 1st step of the memory 1 is set to "OFF", even pressing the  button will not enter the test; When the step connection of the 1st step of the memory 1 is set to "ON", the step connection of the 2nd step of the memory 1 is set to "OFF", the test is stopped after the test is passed in the 1st step of the memory 1; When the step connection of the 1st step of the memory 1 is set to "ON", the step connection of the 2nd step of the memory 1 is set to "ON", after the test is passed in the 1st step of the memory 1, the test will automatically proceed to the 2nd step. If the step connection is set to "ON", "*" will be displayed after "Memory" in <MeasDisp> page. The

factory settings from M1-1 to M50-9 have the same setting, and each step of the memory needs to be turned on, after the connection test is completed, the next memory can be executed. For example, in memory 1, only the step connection of step 1, step 2, step 3, and step 4 is set to "ON", and the step connection of step 1 of the memory 2 is set to "ON", only M1-1, M1- 2, M1-3, M1-4 are executed, M2-1 will not be executed, because the step connections of M1-5, M1-6, M1-7, M1-8, M1-9 are "OFF". See the programmable mode output function for details.

2) Operation







Make use of the  key or the  to move the cursor to this parameter option, the soft-key zone displays the function menu of this parameter. This parameter can be changed to **OFF**, **Front**, or **BACK**.

■ AP HiLmt

1) Description

This parameter is used to set the upper limit of the peak current. When the voltage mode is "AUTO" and the voltage is less than 150V, the range is 0.0~33.6A; when the voltage mode is "AUTO" and the voltage is greater than 150V or the voltage mode is "HIGH", the range is 0.0~16.8A. When this parameter is set to 0.0, this function is turned off.

2) Operation







Make use of the  key or the  to move the cursor to this parameter option, then change it with the front panel numeric keys, and finish with  or  keys to confirm the change. If you do not want to change the parameter value or press the wrong numeric key when changing with the numeric keys, you can cancel it by pressing the  key or  key.

■ AP LoLmt

1) Description

This parameter is used to set the lower limit of the peak current. When the voltage mode is "AUTO" and the voltage is less than 150V, the range is 0.0~33.6A; when the voltage mode is "AUTO" and the voltage is greater than 150V or the voltage mode is "HIGH", the range is 0.0~16.8A. When this parameter is set to 0.0, this function is turned off.

2) Operation



Make use of the  key or the  to move the cursor to this parameter option, then change it with the front panel numeric keys, and finish with  or  keys to confirm the change. If you do not want to change the parameter value or press the wrong numeric key when changing with the numeric keys, you can cancel it by pressing the  key or  key.

■ P HiLmt

1) Description

This parameter is used to set the upper limit of the output power. The range is from 0.0 to 1000W. When this parameter is set to 0.0, this function is turned off.

2) Operation

Make use of the  key or the  to move the cursor to this parameter option, then change it with

the front panel numeric keys, and finish with **ENTER** or **OK** keys to confirm the change. If you do not want to change the parameter value or press the wrong numeric key when changing with the numeric keys, you can cancel it by pressing the **←** key or **ESC** key.

■ P LoLmt

1) Description

This parameter is used to set the lower limit of the output power. The range is from 0.0 to 1000W. When this parameter is set to 0.0, this function is turned off.

2) Operation

Make use of the **▼** key or the **knob** to move the cursor to this parameter option, then change it with the front panel numeric keys, and finish with **ENTER** or **OK** keys to confirm the change. If you do not want to change the parameter value or press the wrong numeric key when changing with the numeric keys, you can cancel it by pressing the **←** key or **ESC** key.

■ PF HiLmt

1) Description

This parameter is used to set the upper limit of the power factor. The range is 0.000~1.000. When this parameter is set to 0.000, it means that this function is off.

2) Operation

Make use of the **▼** key or the **knob** to move the cursor to this parameter option, then change it with the front panel numeric keys, and finish with **ENTER** or **OK** keys to confirm the change. If you do not want to change the parameter value or press the wrong numeric key when changing with the numeric keys, you can cancel it by pressing the **←** key or **ESC** key.

■ PF LoLmt

1) Description

This parameter is used to set the low limit of the power factor. The range is 0.000~1.000. When this parameter is set to 0.000, it means that this function is off.

2) Operation



Make use of the **▼** key or the **knob** to move the cursor to this parameter option, then change it with the front panel numeric keys, and finish with **ENTER** or **OK** keys to confirm the change. If you do not want to change the parameter value or press the wrong numeric key when changing with the numeric keys, you can cancel it by pressing the **←** key or **ESC** key.

■ TimeUnit

1) Description

This parameter is used to change the parameter delay time and dwell time unit. You can select "SECOND", "MINUTE" or "HOUR" .

2) Operation







Make use of the  key or the  to move the cursor to this parameter option, the soft-key area displays the function menu of this parameter. This parameter can be changed by **SEC** , **MIN** or **HOURL** Soft keys.

■ DelayTime

1) Description

This parameter is used to set the delay determination time, which ranges from 0.1 to 999.9s.

2) Operation







Make use of the  key or the  to move the cursor to this parameter option, then change it with the front panel numeric keys, and finish with  or  keys to confirm the change. If you do not want to change the parameter value or press the wrong numeric key when changing with the numeric keys, you can cancel it by pressing the  key or  key.

■ DwellTime

1) Description

This parameter is used to set the test time, which ranges from 0.1 to 999.9s.

2) Operation







Make use of the  key or the  to move the cursor to this parameter option, then change it with the front panel numeric keys, and finish with  or  keys to confirm the change. If you do not want to change the parameter value or press the wrong numeric key when changing with the numeric keys, you can cancel it by pressing the  key or  key.

■ R_UpTime

1) Description

This parameter is used to set the rising time when the output voltage rises from 0V to the set voltage, and the range is 0.1~999.9s.

2) Operation





Make use of the  key or the  to move the cursor to this parameter option, then change it with the front panel numeric keys, and finish with  or  keys to confirm the change. If you do not want to change the parameter value or press the wrong numeric key when changing with the numeric keys, you can cancel it by pressing the  key or  key.



■ R_DnTime

1) Description

This parameter is used to set the falling time when the output voltage drops from the set voltage to 0V, and the range is 0.1~999.9s.

2) Operation

Make use of the  key or the  to move the cursor to this parameter option, then change it with the front panel numeric keys, and finish with  or  keys to confirm the change. If you do not







want to change the parameter value or press the wrong numeric key when changing with the numeric keys, you can cancel it by pressing the  key or  key.

■ SD Volt

1) Description

This parameter indicates the operating voltage of surge/drop, which ranges from 0.0 to 300V. When the parameter value is greater than the set voltage, it is a surge; when it is less than the set voltage, it is a drop. This parameter is displayed when the Surge/Drop option in <Setup> COMMON page is turned on. See the surge drop function for details.

2) Operation







Make use of the  key or the  to move the cursor to this parameter option, then change it with the front panel numeric keys, and finish with  or  keys to confirm the change. If you do not want to change the parameter value or press the wrong numeric key when changing with the numeric keys, you can cancel it by pressing the  key or  key.

■ SD Site

1) Description

This parameter represents the position where the Surge/Drop appears, which can be calculated by the time between this position and the 0 phase point. This parameter is displayed when the Surge/Drop option in <Setup> COMMON page is turned on. When the “SD Cont” is turned on, the range is 0~20ms. When “SD Cont” is turned off, the range is 0~99ms. For details, please refer to Surge/Drop function instruction.

2) Operation







Make use of the  key or the  to move the cursor to this parameter option, then change it with the front panel numeric keys, and finish with  or  keys to confirm the change. If you do not want to change the parameter value or press the wrong numeric key when changing with the numeric keys, you can cancel it by pressing the  key or  key.

■ SD Time

1) Description

This parameter indicates the waveform width of the surge or drop. This parameter is displayed when the Surge/Drop option of the menu bar's general setting is turned on. When the parameter SD connection (SD Cont) is turned on, its setting range is 0~20ms; when the parameter SD connection (SD Cont) is turned off, its setting range is 0~99ms. See the Surge/Drop function for details.

2) Operation

Make use of the  key or the  to move the cursor to this parameter option, then change it with the front panel numeric keys, and finish with  or  keys to confirm the change. If you do not want to change the parameter value or press the wrong numeric key when changing with the numeric keys, you can cancel it by pressing the  key or  key.

■ SD Cont

■ Description

This parameter indicates whether the Surge or Drop is triggered automatically or manually. When this parameter is set to "ON", press **ON/OFF** button, the system will execute the trigger action continuously, sending a Surge or Drop wave every 100ms. When this parameter is set to "OFF", press **ON/OFF** button, the instrument will execute trigger action every time when pressing **TRIG** button. This parameter is displayed when the Surge/Drop option in <ProgramSetup> COMMON page is turned on. For details, please refer to Surge/Drop function instruction.

■ Operation

Make use of **▼** key or the **knob** to move the cursor to this parameter option, then the soft key zone will display the corresponding function menu, change the value with soft keys.

3.3.2 Common Setting

3.3.2.1 Description and Operation

1) Description

Under the <ProgramSetup> COMMON page, users can set the parameters as shown in figure 3-13.

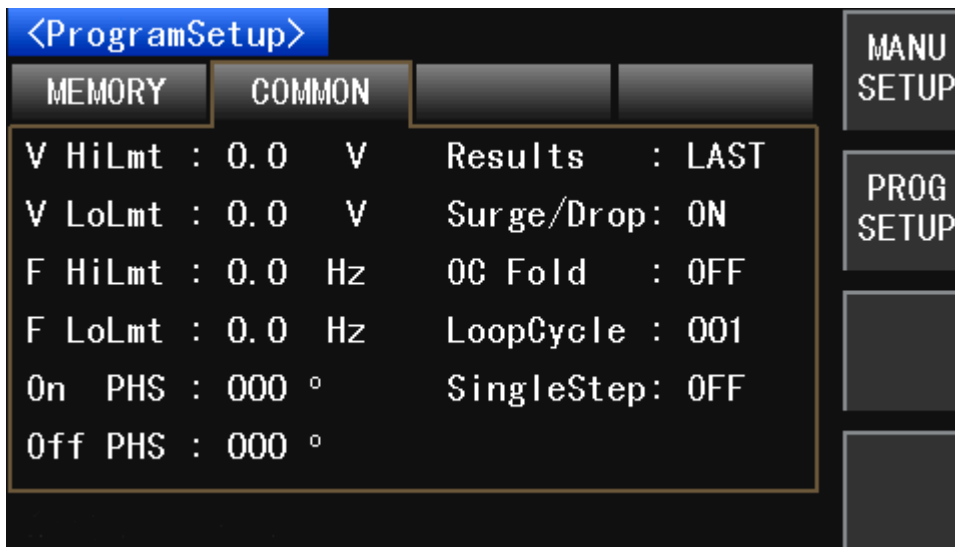

Figure 3-13 General Setting of <programmable mode>

2) Operation

Press **SETUP** button, then press the **PROG SETUP** button in the soft-key zone, then make use of **▼** button or the knob to switch to COMMON page.







3.3.2.2 Setting Parameters Description and Operation

■ V HiLmt

1) Description

This parameter is used to set the upper limit of the output voltage, which ranges from 0.0 to 300.0V.

2) Operation







Make use of the  key or the  to move the cursor to this parameter option, then change it with the front panel numeric keys, and finish with  or  keys to confirm the change. If you do not want to change the parameter value or press the wrong numeric key when changing with the numeric keys, you can cancel it by pressing the  key or  key.

■ V LoLmt

1) Description

This parameter is used to set the lower limit of the output voltage, which ranges from 0.0 to 300.0V.

2) Operation







Make use of the  key or the  to move the cursor to this parameter option, then change it with the front panel numeric keys, and finish with  or  keys to confirm the change. If you do not want to change the parameter value or press the wrong numeric key when changing with the numeric keys, you can cancel it by pressing the  key or  key.

■ F HiLmt

1) Description

This parameter is used to set the upper limit of the output frequency, which ranges from 45.0 to 500.0 Hz.

2) Operation







Make use of the  key or the  to move the cursor to this parameter option, then change it with the front panel numeric keys, and finish with  or  keys to confirm the change. If you do not want to change the parameter value or press the wrong numeric key when changing with the numeric keys, you can cancel it by pressing the  key or  key.

■ F LoLmt

1) Description

This parameter is used to set the lower limit of the output frequency, which ranges from 45.0 to 500.0 Hz.

2) Operation







Make use of the  key or the  to move the cursor to this parameter option, then change it with the front panel numeric keys, and finish with  or  keys to confirm the change. If you do not want to change the parameter value or press the wrong numeric key when changing with the numeric keys, you can cancel it by pressing the  key or  key.

■ ONPHS

1) Description

This parameter is used to set the starting angle phase of the output waveform, which ranges from 0 to 359° .

2) Operation







Make use of the  key or the  to move the cursor to this parameter option, then change it with the front panel numeric keys, and finish with  or  keys to confirm the change. If you do not want to change the parameter value or press the wrong numeric key when changing with the numeric keys, you can cancel it by pressing the  key or  key.

■ OFFPHS

1) Description

This parameter is used to set the ending angle phase of the output waveform, which ranges from 0 to 359° .

2) Operation





Make use of the  key or the  to move the cursor to this parameter option, then change it with the front panel numeric keys, and finish with  or  keys to confirm the change. If you do not want to change the parameter value or press the wrong numeric key when changing with the numeric keys, you can cancel it by pressing the  key or  key.

■ Results

1) Description

This parameter is used to set the status of the display page of the last test result, there are three modes: "LAST", "ALL" and "P/F". When set to "LAST", the display will show the final test result after the test is over; When set to "ALL", the display will show all test results after the test is over; When set to "P/F", the display will show "PASS" or "FAIL" after the test is over. In the manual mode, when the voltage output value and the frequency value are in the range of the high voltage limit, the low voltage limit, the high frequency limit, and the low frequency limit, "PASS" is displayed at the end of the test; If it is not within the range, "FAIL" is displayed, out of range is displayed, and shows the parameter values that are out of range. For details, please refer to result display function.

2) Operation



Make use of the  key or the  to move the cursor to this parameter option, the soft-key zone displays the function menu of this parameter, this parameter can be changed by the soft-key ,  or .

■ Surge/Drop

1) Description

This parameter is used to set whether to enable the Surge/Drop function. When this parameter is set to "ON", the MEMORY page will display "SD Volt", "SD Site", "SD Time", "SD Cont"; When this parameter is set to "OFF", these parameters are not displayed. For details, please refer to Surge/Drop function.

2) Operation

Make use of the  key or the  to move the cursor to this parameter option, the soft-key zone



displays the function menu for this parameter, this parameter can be changed via the soft-key **ON** or **OFF**.

■ OC Fold

1) Description

This parameter is used to set whether to enable the over-current fold function. When this parameter is set to "ON", the output voltage will decrease due to the load increased, the current output will be kept constant at current high limit. (Note: After this function is enabled, the current will output only if the output current is greater than the current high limit setting value.) When this parameter is set to "OFF", the over-current fold function is turned off.

2) Operation







Make use of the  key or the  to move the cursor to this parameter option, the soft-key zone displays the function menu of this parameter, this parameter can be changed via the soft-key **ON** or **OFF**.

■ LoopCycle

1) Description

This parameter indicates the total number of cycles for all memory sequences when the step connection is turned on. Set to "000", indicating continuous loop output of current memory sequence; Set to "001~999", indicating the memory sequence will be cycled several times based on your setting. See program setting function for details.

2) Operation

Make use of the  key or the  to move the cursor to this parameter option, then change it with the front panel numeric keys, and finish with  or  keys to confirm the change. If you do not want to change the parameter value or press the wrong numeric key when changing with the numeric keys, you can cancel it by pressing the  key or  key.

■ SingleStep

1) Description

This parameter is used to set whether to manually enter the next step. When this parameter is set to "ON", after the first step of test is finished you need to press the  button to execute the next step; When this parameter is set to "OFF", the next step will be automatically executed at the end of the 1st step of test.

2) Operation

Make use of the  key or the knob to move the cursor to this parameter option, the soft-key area displays the function menu of this parameter. This parameter can be changed by soft keys.

3.4 <System Setting>

3.4.1 System Environment

3.4.1.1 Description and Operation

1) Description

Under the SysEnv of <SysSetup>, users can set system language, pass beep, fail beep, password, alarm beep, key beep, time, date and other parameters. As shown in Figure 3-14.

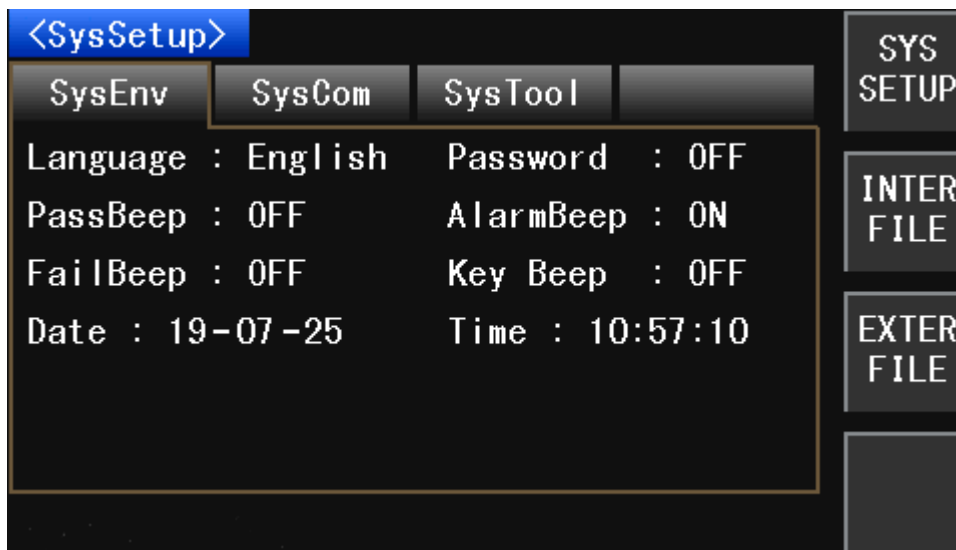

Figure 3-14 system environment of <System Setting>

2) Operation

Press the **SYSTEM** button to enter the system environment interface under <SysSetup> page by default. If you are not on this page, make use of **▼** button or the **knob** to move the cursor to the menu bar and then switch to this page.

3.4.1.2 Setting Parameters Description and Operation

■ Language

1) Description

This parameter is used to set the system language. You can choose English or Chinese.

2) Operation

Make use of the **▼** key or the knob to move the cursor to this parameter option, the soft-key area displays the function menu of this parameter. This parameter can be changed with soft keys.

■ PassWord

1) Description

This parameter is used to set the instrument password. The instrument is shipped without a password. When the password is turned on, re-boot the instrument requires a password. Please keep the password in mind.

2) Operation

Make use of the  key or the knob to move the cursor to this parameter option, the soft-key area displays the function menu of this parameter. This parameter can be changed with soft keys.

■ PassBeep

1) Description

This parameter is used to set the sound when the instrument passes the test.

2) operation

Make use of the  key or the knob to move the cursor to this parameter option, the soft-key area displays the function menu of this parameter. This parameter can be changed with soft keys.

■ FailBeep

1) Description

This parameter is used to set the sound when the instrument fails the test.

2) Operation

Make use of the  key or the knob to move the cursor to this parameter option, the soft-key area displays the function menu of this parameter. This parameter can be changed with soft keys.

■ Alarm Beep

1) Description

This parameter is used to set whether the alarm beep occurs when run into an abnormality during the test.

2) Operation

Make use of the  key or the knob to move the cursor to this parameter option, the soft-key area displays the function menu of this parameter. This parameter can be changed with soft keys.

■ Key Beep

1) Description

This parameter is used to set whether the key tone is enabled when pressing the front panel keys.

2) Operation







Make use of the  key or the knob to move the cursor to this parameter option, the soft-key area displays the function menu of this parameter. This parameter can be changed with soft keys.

■ Date

1) Description

This parameter is used to set the date of the system.

2) Operation







Make use of the  key or the  to move the cursor to this parameter option, then change it with the front panel numeric keys, and finish with  or  keys to confirm the change. If you do not want to change the parameter value or press the wrong numeric key when changing with the numeric keys, you can cancel it by pressing the  key or  key.

■ Time

1) Description

This parameter is used to set the time of the system.

2) Operation

Make use of the  key or the  to move the cursor to this parameter option, then change it with the front panel numeric keys, and finish with  or  keys to confirm the change. If you do not want to change the parameter value or press the wrong numeric key when changing with the numeric keys, you can cancel it by pressing  key or  key.

3.4.2 System Communication

3.4.2.1 Description and Operation

1) Description

Under the SysCom of <SysSetup>, users can set parameters such as bus mode, baud rate, bus address, and PLC On off. As shown in Figure 3-15.

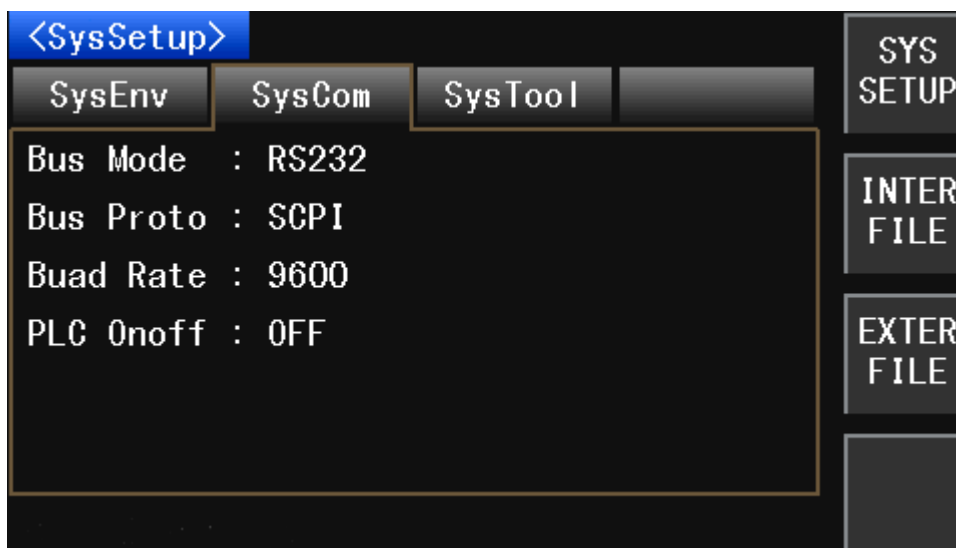

Figure 3-15 system communication of<System Setting>

2) Operation

Press the **SYSTEM** button, then press **▼** or use the **knob** to move the cursor to the menu bar, then switch to SysCom page with **arrow keys** or the **knob**.

3.4.2.2 Parameters Setting Description and Operation

■ Bus Mode

1) Description

This parameter is used to set the communication interface of the instrument. It provides two modes which are “RS232”, and “USBCOM”. When set to “RS232”, the RS232 interface is selected, and communication can be performed through the RS232 port on the rear panel of the instrument; When set to “USBCOM”, the USBCOM interface is selected and can be communicated via the USB port (USB DEVICE) on the rear panel of the instrument. See the bus interface chapter for details.

2) Operation

Make use of the **▼** key or the **knob** to move the cursor to this parameter option, the soft-key area displays the function menu of this parameter. This parameter can be changed with soft keys.

■ Bus Proto

1) Description

This parameter is used to set the protocol of the instrument RS232 communication interface. This parameter can be set to “SCPI” mode or “MODBUS” mode.

2) Operation

Make use of the **▼** key or the **knob** to move the cursor to this parameter option, the soft-key area displays the function menu of this parameter. This parameter can be changed with soft keys.

■ Baud Rate

1) Description

This parameter is used to set the baud rate of the RS232 interface of the instrument. There are a total of 8 baud rates to choose from, which are 4800, 9600, 14400, 19200, 38400, 57600, 96000, and 115200.

2) Operation

Make use of the **▼** key or the **knob** to move the cursor to this parameter option, the soft-key area displays the function menu of this parameter. This parameter can be changed with soft keys.

■ Bus Addr

1) Description

This parameter is used to set the address of the RS232 interface MODBUS protocol of the instrument. Can be set from 1 to 31.

2) Operation

Make use of the key or the knob to move the cursor to this parameter option, the soft-key area displays the function menu of this parameter. This parameter can be changed with soft keys.

■ PLC Onoff

1) Description

This parameter is used to set whether the remote control function is enabled. See the PLC function for details.

2) Operation

Make use of the key or the knob to move the cursor to this parameter option, the soft-key area displays the function menu of this parameter. This parameter can be changed with soft keys.

3.4.3 System Tool

3.4.3.1 Description and Operation

1) Description

Under the SysTool of <SysSetup>, users can set parameters such as last state on, factory reset, setup reset, and system upgrade. As shown in Figure 3-16.

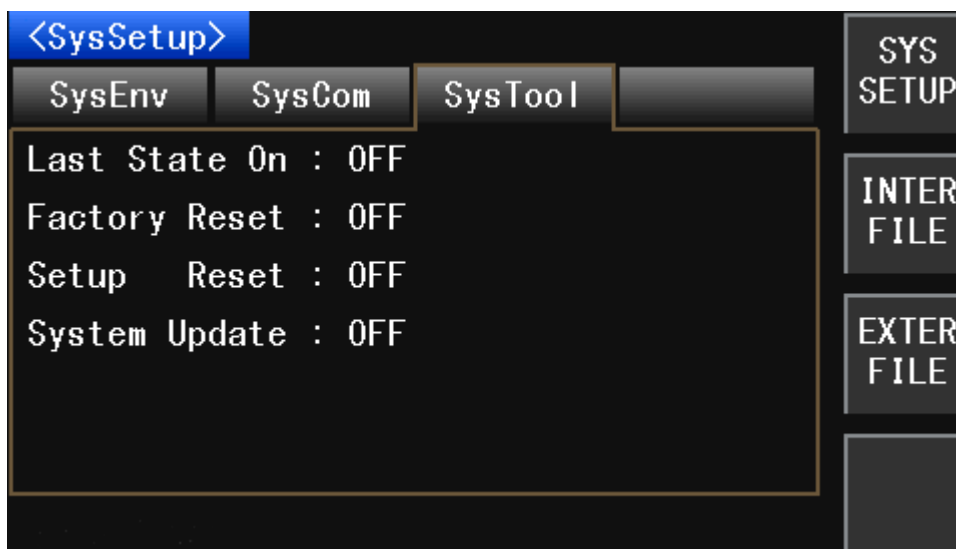

Figure3-16 System Tool of <System Setting>

2) Operation

Press the SYSTEM button, then press or use the knob to move the cursor to the menu bar, then switch to SysTool page with arrow keys or the knob.



3.4.3.2 Setting Parameters Description and Operation

■ Last State On

1) Description

This parameter indicates that the next time while user power on the instrument whether the system would keep the same parameter settings as it was the last time. When set to “ON”, keep the same parameter settings; when set to “OFF”, restore to default settings.

2) Operation



Make use of the  key or the  to move the cursor to this parameter option, the soft-key area displays the function menu of this parameter. This parameter can be changed with soft keys.

■ Factory Reset

1) Description

This parameter is used to restore the system to factory settings.

2) Operation



Make use of the  key or the  to move the cursor to this parameter option, the soft-key area displays the function menu of this parameter. This parameter can be changed with soft keys.

■ Setup Reset

1) Description

This parameter is used to restore all parameters under the instrument measurement settings to their default settings.

2) Operation



Make use of the  key or the  to move the cursor to this parameter option, the soft-key area displays the function menu of this parameter. This parameter can be changed with soft keys.

■ System Update

1) Description

This parameter is used for system upgrade. The system upgrade can be realized while connected with a U disk. The upgrade file is provided by the manufacturer.

2) Operation

Make use of the  key or the  to move the cursor to this parameter option, the soft-key area displays the function menu of this parameter. This parameter can be changed with soft keys.

Chapter 4 File Management

4.1 Internal File

4.1.1 Description

The TH7100 series programmable AC power supply can store all the parameters that set by the user into the internal non-volatile memory in the form of a file. When users need to use the same settings the next time, users do not need to reset the parameters, just load the corresponding file, you can get the same settings as last time. “I” is the short for **Internal**, which stands for the internal non-volatile memory. As shown in Figure 4-1.

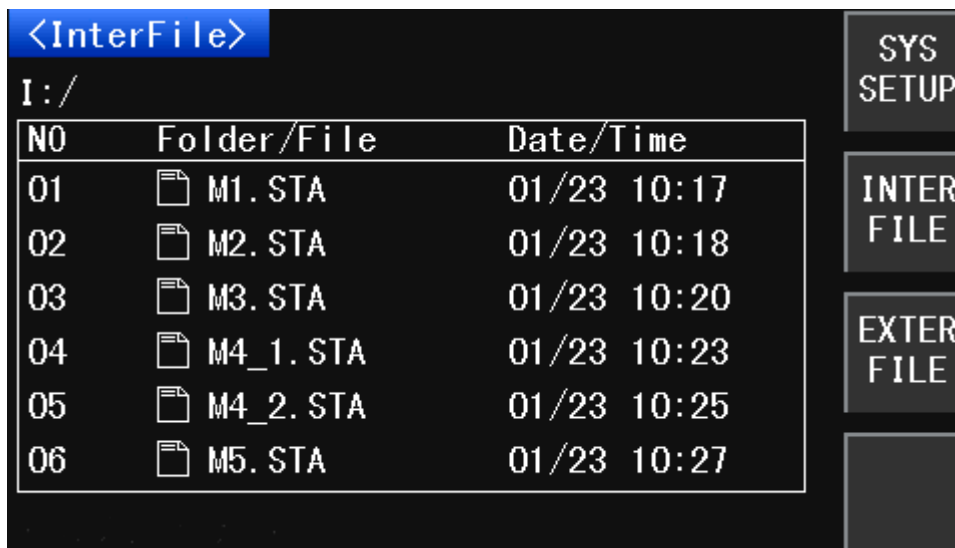

Figure 4-1 Internal File

4.1.2 Operation

Press the **SYSTEM** button, then press **INTER FILE** soft key to enter <InterFile> interface. This instrument can operate on 54 internal files. When the cursor is not in the title bar, press **◀** key or **▶** key to quickly return to the title bar.

■ Save

- 1) Move the **▼** key to the serial number of the empty file, then press the **save** button.
- 2) A character selection panel will pop up in the center of the screen, move the cursor to your desired place with **▲**, **▼**, **◀**, **▶** keys or the **knob**, then press **ADD CHAR** soft key to add characters to the file name in the prompt bar at the bottom of the screen. If you enter the wrong character, press the **BACK SPACE** soft key. If you do not need to save the file at this time, press **EXIT** button.

3) After the file name is entered, press **ENTER** or **OK** to save the file. If the entered file name is the same as the previous file name, a prompt will appear in the prompt bar at the bottom of the screen. If a user did not enter a file name, and pressed **ENTER** or **OK**, the default file name is UNNAMExx. STA (Note: xx represents the current file serial number).

■ **Load**

- 1) Press **▼** button to move the cursor to the file number to be loaded.
- 2) Press the **Load** key to load the file where the cursor is located.

■ **Copy to E:**

- 1) Press **▼** button to move the cursor to the file number to be copied.
- 2) Press the **Copy to E:** soft key to copy the file where the cursor is located to the U disk. If no U disk is plugged in the instrument, an error shall be prompt. In order to operate correctly, please insert a U disk into the front panel USB interface before copy the file.

■ **Delete**

- 1) Press **▼** button to move the cursor to the file number to be deleted.
- 2) Press the **DEL.** key to delete the file where the cursor is located.

4.2 External File

4.2.1 Description

The TH7100 series programmable AC power supply can store all the parameters that set by the user into the external memory in the form of a file, such as a U disk. When users need to use the same settings the next time, users do not need to reset the parameters, just load the corresponding file, you can get the same settings as last time. "E" is the short for **External**, which stands for the external memory. As shown in Figure 4-2.

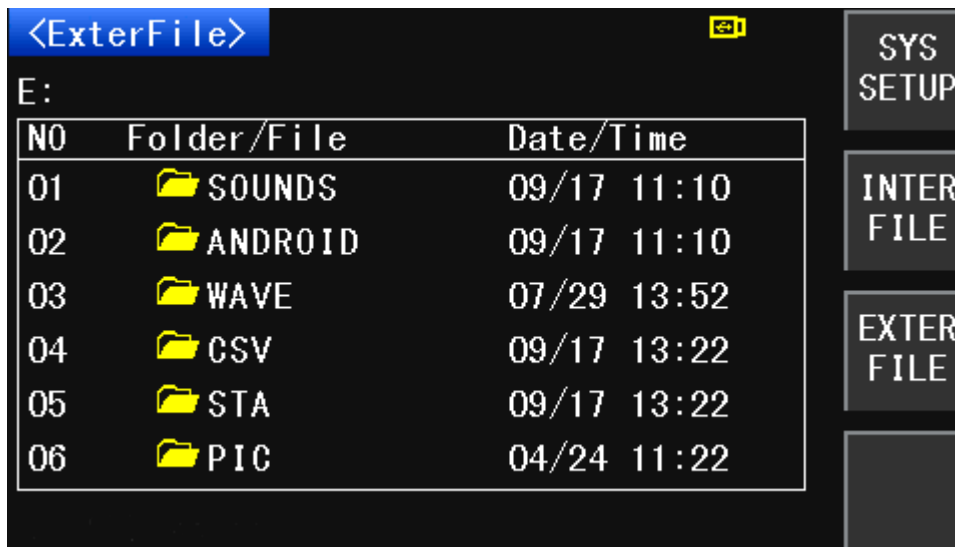

Figure 4-2 External File

The following points should be noted when using a U disk on TH7100 series programmable AC power supply:

- 1) Use a U disk with USB 2.0 interface.
- 2) The U disk file system should be FAT16 or FAT32, and formatted using the FAT16 or FAT32 standard; For U disk over 512M, users are advised to use FAT32 standard for formatting.
- 3) Before connecting the U disk to the TH7100 series instrument, it is recommended to back up the data on this U disk. Tonghui Company is not responsible for data loss in the USB disk when the USB disk is used with this instrument.

In order to efficiently save the instrument data to the USB flash drive, it is recommended not to have too many files or folders in the USB flash drive.

The file format and its use are described in the following table:





Type	Format	Callable	Use
Setting Saving(I U disk)	*.STA	yes	Save the instrument's parameter settings to the internal FLASH.
Setting Saving (E U disk)	*.STA	yes	Save the instrument's parameter settings to U disk
Data Saving (E U disk)	*.CSV	no	Save the test results to U disk

Table 4-1 U disk file type description

4.2.2 Operation

Press the **SYSTEM** key, then press **external file** key to enter the <external file> interface. The instrument can operate on 54 external files. When the cursor is not in the title bar, press the **←** key or **→** key to quickly return to the title bar.

■ Save

- 1) Move the  key to the serial number of the empty file, then press the **save** button.
- 2) A character selection panel will pop up in the center of the screen, move the cursor to your desired place with , , ,  keys or the **knob**, then press **ADD CHAR** soft key to add characters to the file name in the prompt bar at the bottom of the screen. If you enter the wrong character, press the **BACK SPACE** soft key. If you do not need to save the file at this time, press **EXIT** button.
- 3) After the file name is entered, press **ENTER** or **OK** to save the file. If the entered file name is the same as the previous file name, a prompt will appear in the prompt bar at the bottom of the screen. If a user did not enter a file name, and pressed **ENTER** or **OK**, the default file name is UNNAMExx.STA (Note: xx represents the current file serial number).

■ Load

- 1) Press  button to move the cursor to the file number to be loaded.
- 2) Press the **Load** key to load the file where the cursor is located.

■ Copy to I:

- 1) Press  button to move the cursor to the file number to be copied.
- 2) Press the **Copy to I:** soft key to copy the file where the cursor is located to the internal FLASH

■ Delete

- 1) Press  button to move the cursor to the file number to be deleted.
- 2) Press the **DEL.** key to delete the file where the cursor is located.

Chapter 5 Function Introduction

5.1 Function Structure Introduction

The TH7100 series programmable AC power supply supports manual mode and program control mode. Users can set the system parameters to select manual mode or program control mode. The function structure of the instrument is shown in Figure 5-1.

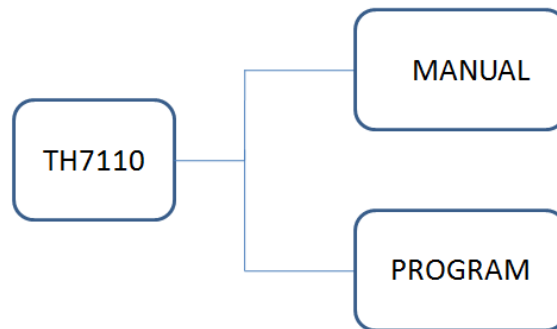

Figure 5-1 Function Structure

In manual mode, there are 50 memory sequences in total. Each memory sequence includes parameters such as voltage, voltage mode, frequency, current high limit, current low limit, SD voltage, SD site, SD time, and SD connection. The 50 memory sequences have common voltage high limit, voltage low limit, frequency high limit, frequency low limit, starting angle, ending angle, test result, surge drop, over current fold, dimmer mode, timer and other parameters. As shown in Figure 5-2.

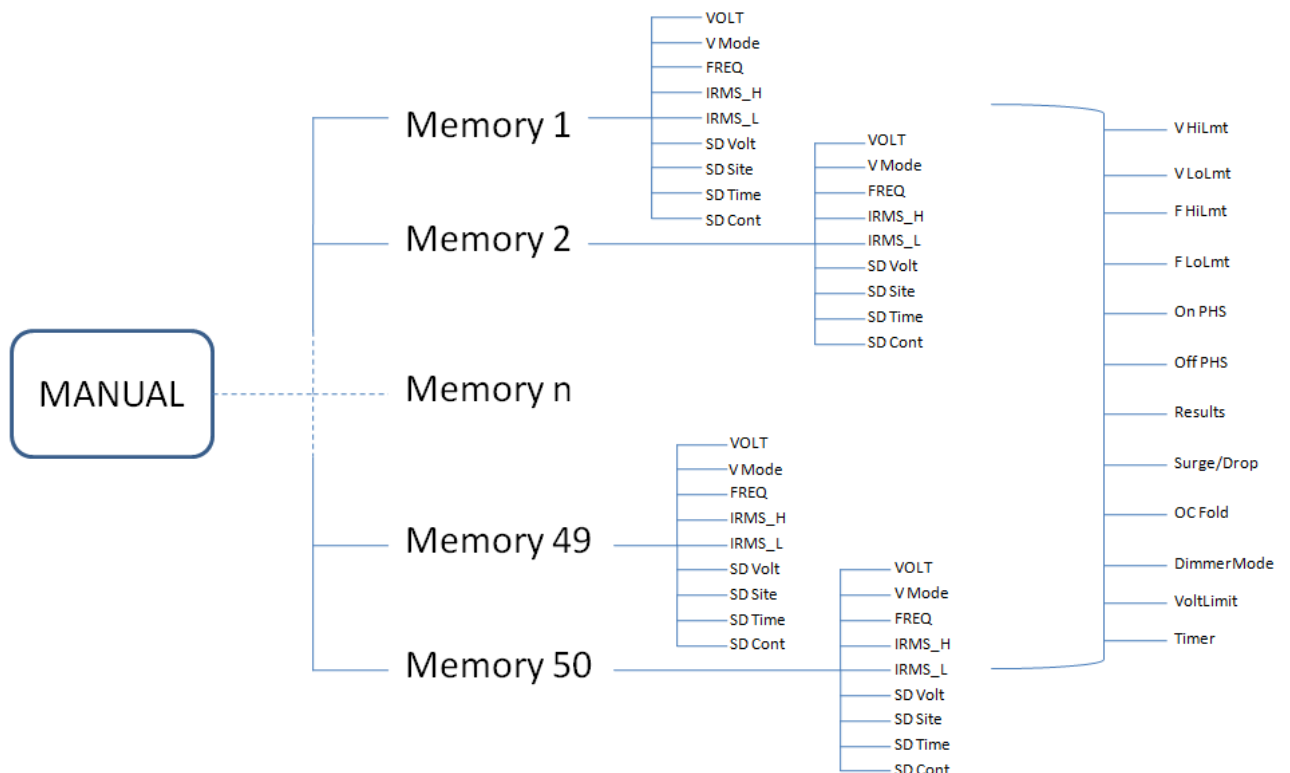

Figure 5-2 Manual Mode

In the programmable mode, there are 50 memory sequences, and each memory sequence includes 9 steps. Each step includes memory number, number of steps, voltage, voltage mode, current high limit, current low limit, frequency, step connection, high limit of pick current, low limit of peak current, power high limit, power low limit, PF high limit, PF low limit, time unit, delay time, dwell time, ramp up time, ramp down time, SD voltage, SD site, SD time, SD connection and other parameters. All the steps share the voltage high limit, voltage low limit, frequency high limit, frequency low limit, starting angle, ending angle, test result, surge drop, over current fold, loop cycle, step cycle and other parameters. As shown in Figure 5-3.

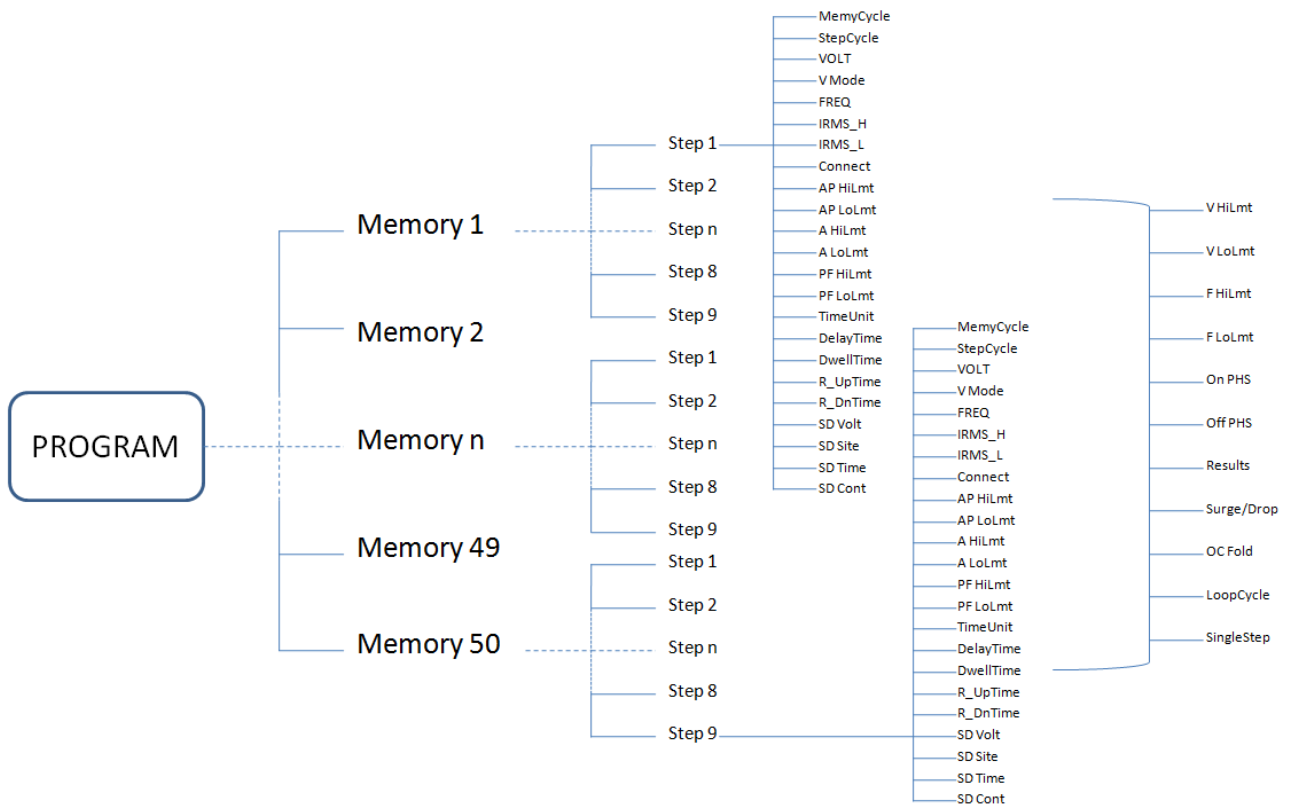

Figure 5-3 programmable Mode

5.2 Programmable Mode Output Function

The TH7100 series programmable AC power supply can set different parameters through each step to achieve powerful programmable output functions. TH7100 series instruments have the same factory default settings which is M1-1 to M50-9, the step connection of the 9 steps of each memory sequence need to be turned on, so that after these 9 step connection tests are completed, the next memory sequence can be performed. For example, in memory 1, only the step connection of step 1, step 2, step 3, and step 4 is set to "ON", and the step connection of step 1 of the memory 2 is set to "ON", only M1-1, M1- 2, M1-3, M1-4 are executed, M2-1 will not be executed, because the step connections of M1-5, M1-6, M1-7, M1-8, M1-9 are "OFF".

For example, when the LoopCycle is set to 2, MemoryCycle of memory M1 is set to 1.

M1-1:Connect=ON,StepCycle=2;

M1-2:Connect=ON,StepCycle=1;

M1-3:Connect=ON,StepCycle=2;

M1-4:Connect=ON,StepCycle=2;

M1-5:Connect=ON,StepCycle=3;

M1-6:Connect=ON,StepCycle=1;

Then the whole test process is as follows:

M1-1→M1-1→M1-2→M1-3→M1-3→M1-4→M1-4→M1-5→M1-5→M1-5→M1-6→

M1-1→M1-1→M1-2→M1-3→M1-3→M1-4→M1-4→M1-5→M1-5→M1-5→M1-6

when the LoopCycle is set to 2, MemoryCycle of memory M1 is set to 2.

M1-1:Connect=ON,StepCycle=2;

M1-2:Connect=ON,StepCycle=1;

M1-3:Connect=ON,StepCycle=2;

M1-4:Connect=ON,StepCycle=2;

M1-5:Connect=ON,StepCycle=3;

M1-6:Connect=ON,StepCycle=1;

M1-7:Connect=ON,StepCycle=3;

M1-8:Connect=ON,StepCycle=1;

M1-9:Connect=ON,StepCycle=2;

MemoryCycle of memory M2 is set to 3.

M2-1:Connect=ON,StepCycle=2;

M2-2:Connect=ON,StepCycle=3;

Then the whole test process is as follows:

M1-1→M1-1→M1-2→M1-3→M1-3→M1-4→M1-4→M1-5→M1-5→M1-5→M1-6→M1-7→M1-7→M1-7→
M1-8→M1-9→M1-9→

M1-1→M1-1→M1-2→M1-3→M1-3→M1-4→M1-4→M1-5→M1-5→M1-5→M1-6→M1-7→M1-7→M1-7→
M1-8→M1-9→M1-9→

M2-1→M2-1→M2-2→M2-2→M2-2→M2-1→M2-1→M2-2→M2-2→M2-2→M2-1→M2-1→M2-2→M2-2→
M2-2→

M1-1→M1-1→M1-2→M1-3→M1-3→M1-4→M1-4→M1-5→M1-5→M1-5→M1-6→M1-7→M1-7→M1-7→
M1-8→M1-9→M1-9→

M1-1→M1-1→M1-2→M1-3→M1-3→M1-4→M1-4→M1-5→M1-5→M1-5→M1-6→M1-7→M1-7→M1-7→
M1-8→M1-9→M1-9→

M2-1→M2-1→M2-2→M2-2→ M2-2→M2-1→M2-1→M2-2→M2-2→M2-2→

M2-1→M2-1→M2-2→M2-2→M2-2

5.3 Surge Drop Function

The TH7100 series programmable AC power supply can generate a surge/drop waveform by setting parameters of surge drop voltage, site, time, and connection.

■ SD Volt

This parameter indicates the operating voltage of the surge/drop, which ranges from 0.0 to 300V. When this parameter value is greater than the set voltage, it is a surge; when it is less than the set voltage, it is a drop. This parameter is displayed when the Surge/Drop option under the <ProgramSetup> COMMON page is turned on.

■ SD Site

This parameter represents the position where the Surge/Drop appears, which can be calculated by the time between this position and the 0 phase point. This parameter is displayed when the Surge/Drop option in <Setup> COMMON page is turned on. When the "SD Cont" is turned on, the range is 0~20ms; When "SD Cont" is turned off, the range is 0~99ms.

■ SD Time

This parameter indicates the waveform width of the surge or drop. This parameter is displayed when the Surge/Drop option in <Setup> COMMON page is turned on. When the parameter SD connection (SD Cont) is turned on, its setting range is 0~20ms; when the parameter SD connection (SD Cont) is turned off, its

setting range is 0~99ms.

■ SD Cont

This parameter indicates whether the Surge or Drop is triggered automatically or manually. When this parameter is set to "ON", press **ON/OFF** button, the system will execute the trigger action continuously, sending a Surge or Drop wave every 100ms. When this parameter is set to "OFF", press **ON/OFF** button, the instrument will execute trigger action every time when pressing **TRIG** button. This parameter is displayed when the Surge/Drop option in <ProgramSetup> COMMON page is turned on.

Assume that the output voltage is 100V, the output frequency is 50Hz, the SD voltage is 60V, the SD site is 25ms, and the SD time is 1ms. If the SD Cont function is set to "OFF", press **TRIG** button one time, the drop waveform is shown in figure 5-4.

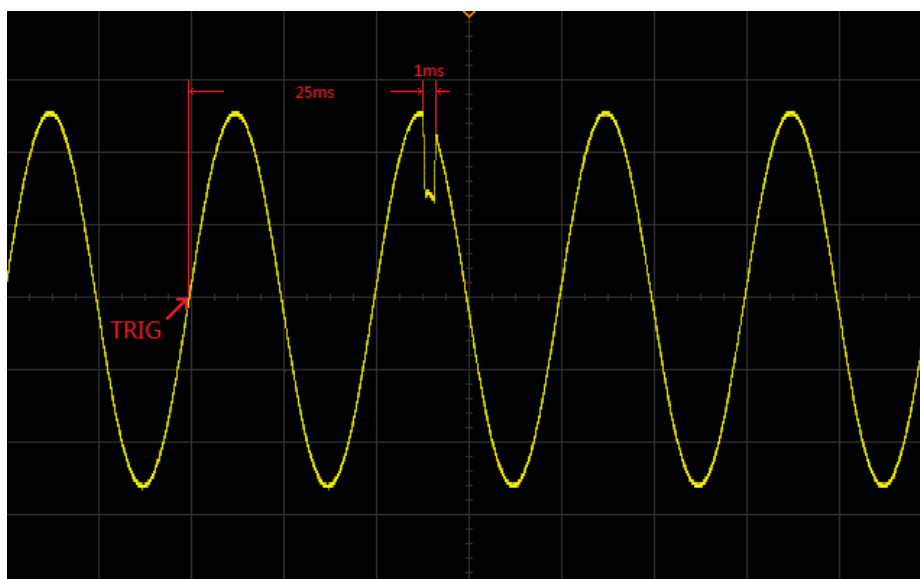

Figure 5-4 Manual Triggered Drop

Assume that the output voltage is 100V, the output frequency is 50Hz, the SD voltage is 50V, the SD site is 10ms, and the SD time is 10ms. If the SD Cont function is set to "ON", the system will continuously execute the trigger action, a surge/drop is generated every 100ms cycle or so. The surge/drop waveform is shown in Figure 5-5.

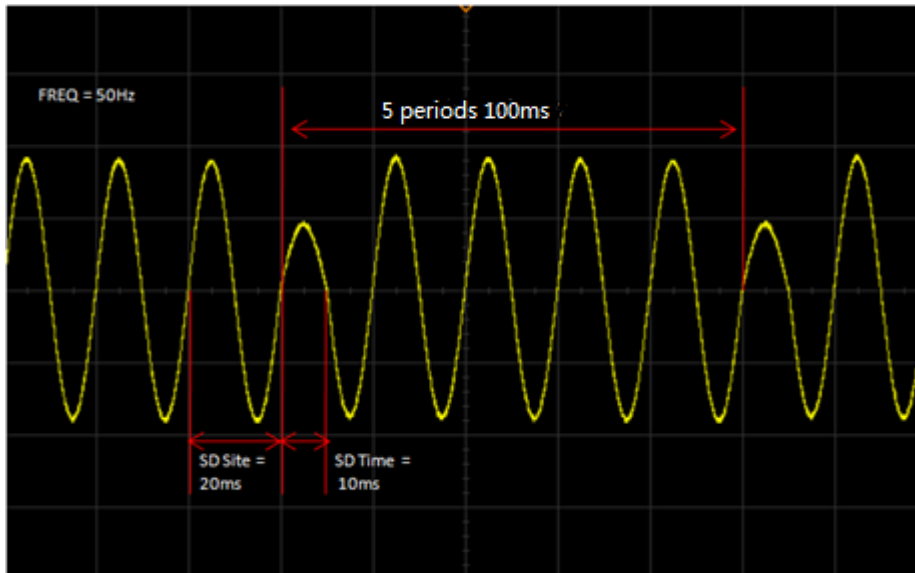

Figure 5-5 Auto Triggered Drop

5.4 Dimmer Mode Function

This parameter is used to set the front dimmer mode or back dimmer mode. When the dimming mode is turned on, the surge/drop and SD count are enabled by default. In this mode, the manual mode MEMORY setting can only set parameters such as voltage, frequency (45~100Hz), and SD voltage. The measurement display page cannot display the measurement results due to the special waveform, but the waveform can be exported through output interface. The front dimmer mode and back dimmer mode are shown in figure 5-6 and figure 5-7.

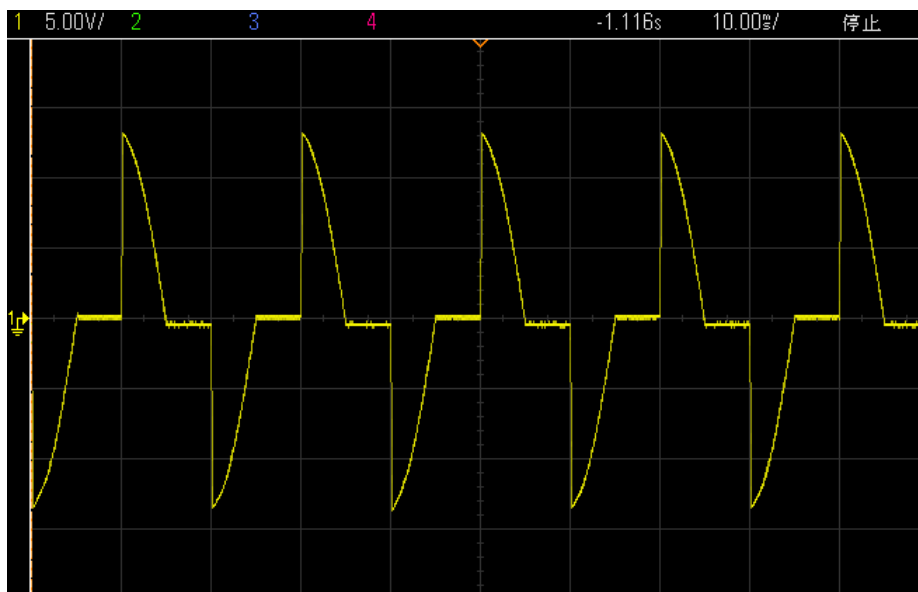

Figure 5-6 Front Dimmer Mode

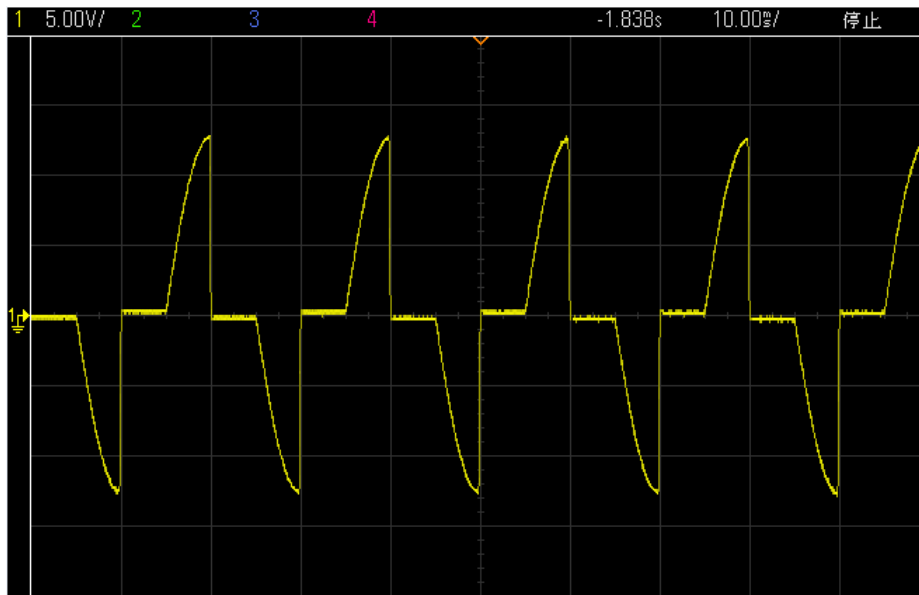

Figure 5-7 Back Dimmer Mode

5.5 Result Display Function

The TH7100 series programmable AC power supply provides four result display functions, which are "NONE", "LAST", "ALL", and "P/F". When set to "NONE", the screen will not display the test results after the test is completed. As shown in figure 5-8.

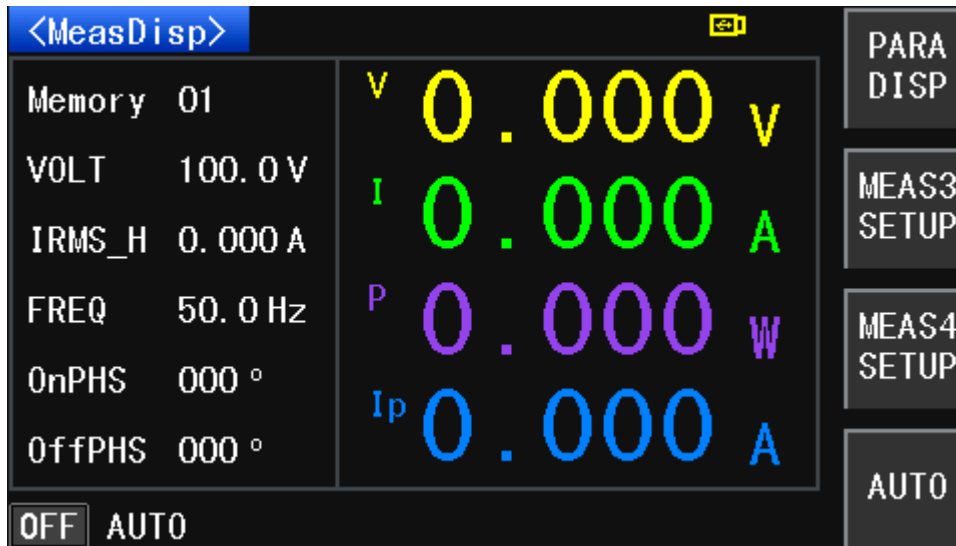

Figure 5-8 The test result is "NONE" display

When set to "LAST", the screen will display the final test result after the test is completed. As shown in Figure 5-9.

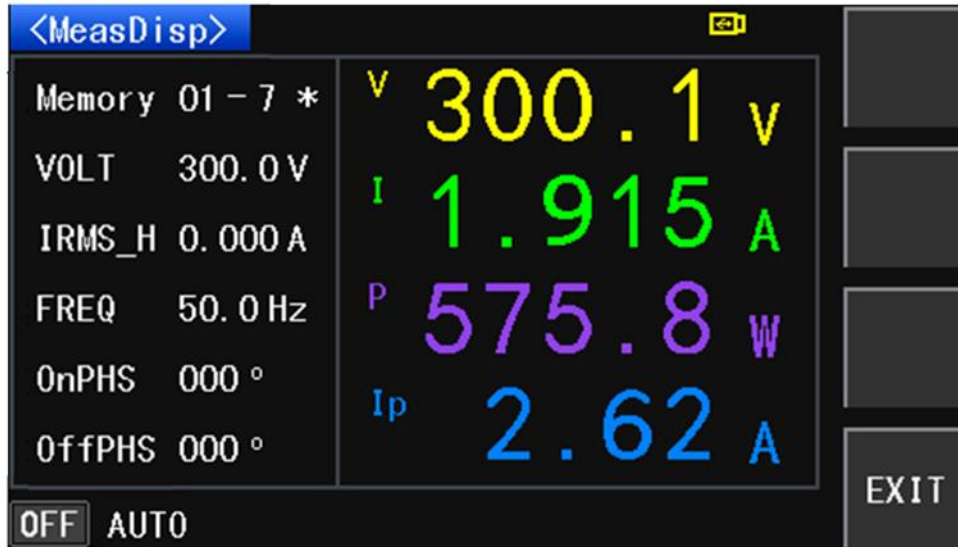

Figure 5-9 The test result is "LAST" display

When set to "ALL", press the **test result** key after the test is finished, all the test results will be displayed. Users can save the test results to a USB flash drive for backup. As shown in figure 5-10.



Figure 5-10 The test result is "ALL" display

When set to "P/F", "PASS" or "FAIL" will be displayed after the test is finished. The output result of the test is judged based on high/low limit setting values. When the output value is within the range of the voltage high limit, the voltage low limit, the frequency high limit, and the frequency low limit, "PASS" is displayed after the test ends, as shown in figure 5-11.

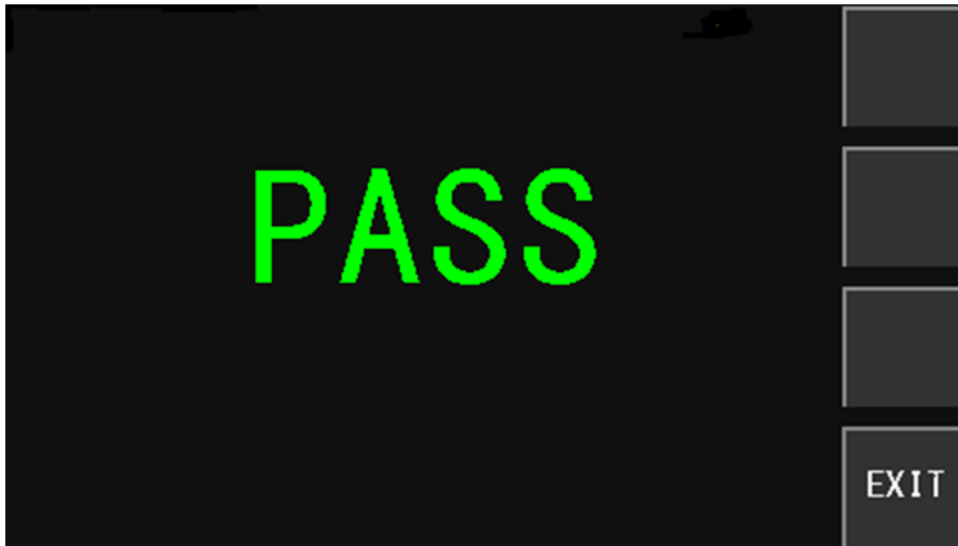

Figure 5-11 The test result is "P/F" showing "PASS"

If it is not in the range, "FAIL" is displayed, and prompt specific parameters that are not within range, as shown in figure 5-12.



Figure 5-12 The test result is "P/F" showing "FAIL"

5.6 Protection Function

TH7100 series programmable AC power supply provides the following protection: HI-A, OVP, LVP, OCP, OPP, OTP.

- HI-A

When the output current is greater than the set current, the display will show "HI-A", alarm beep(when the

beep is on), the **ON/OFF** button indicator flashes.

■ OVP

When the voltage output range is from 0V to 150V, and the output voltage exceeds the set voltage 5V, or when the voltage output range is from 0V to 300V, and the output voltage exceeds the set voltage 10V, the display will display “OVP”, alarm beep (when the beep is on), the **ON/OFF** button indicator flashes.

■ LVP

When the voltage output range is from 0V to 150V, and the output voltage less than the set voltage 5V, or when the voltage output range is from 0V to 300V, and the output voltage less than the set voltage 10V, the display will display “LVP”, alarm beep (when the beep is on), the **ON/OFF** button indicator flashes.

■ OCP

When the output current exceeds 110% of the rated full load current for 1 s continuously or the output is shorted, the display will show “OCP”, alarm beep (when the beep is on), the **ON/OFF** button indicator flashes.

■ OPP

When the output power exceeds 105%~110% of the rated full load power for 5s continuously, or less than 1s output power exceeds 110% of the rated full load power, the display will show "OPP", alarm beep (when the beep is on), the **ON/OFF** button indicator flashes.

■ OTP

When the temperature of the heat sink of the instrument exceeds 60 °C, the fan accelerates; When the temperature of the heat-sink of the machine exceeds 130 °C, the display will show “OTP”, alarm beep (when the beep is on), the **ON/OFF** key indicator flashes.

Note: When an abnormal action occurs, the display will show the status of the message when the error occurred, at this point, the output will be turned off, alarm beep (when the beep is on), the **ON/OFF** button indicator flashes, press the **ON/OFF** key to release the Alarm.

5.7 Remote Signal Output Function

There is a remote signal output terminal (SIGNALOUT terminal) on the rear panel of the instrument, provide signals such as “PASS”, “FAIL” and “PROCESSING” of the instrument for remote monitoring. This function can only be used if the test result is set to “P/F”. The wiring of each output signal is shown in Figure 5-13.



Figure 5-13 remote control signal output interface

1) PASS Signal Connected between PIN1 and PIN2

Note: After the DUT passes, the relay will connect PIN1 and PIN2. After pressing the **Escape** key, the relay will return

PIN1 and PIN2 to the open state.

2) FAIL Signal Connected between PIN3 and PIN4

Note: After the DUT passes, the relay will connect PIN3 and PIN4. After pressing the **Escape** key, the relay will return PIN3 and PIN4 to the open state.

3) PROCESSING Signal Connected between PIN5 and PIN6

Note: When the instrument is testing, the relay will connect PIN5 and PIN6. After the test is completed, the relay will return PIN5 and PIN6 to the open state.

5.8 Remote Control Function

The remote control signal input terminal (SIGNAL IN terminal) is available on the rear panel of the TH7100 series programmable AC power supply. After PLC Onoff of SysCom under <SysSetup> page is set to ON, connect the remote control device to implement remote control. This terminal is a D-type (9PIN) terminal block male seat, with output switch and input control of 7 groups of memory groups. As shown in Figure5-14

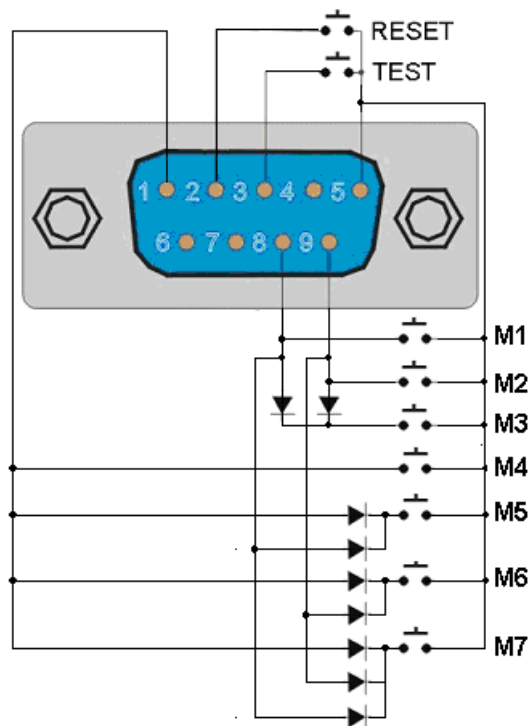

Figure 5-14 Remote control chart

ON: The control switch is connected between PIN3 and PIN5

OFF: The control switch is connected between PIN2 and PIN5

MANUAL Mode:

M1 The control switch is connected between PIN8 and PIN5

M2 The control switch is connected between PIN9 and PIN5

M3 The control switch is connected between PIN8, PIN9 and PIN5

-
- M4 The control switch is connected between PIN1 and PIN5
 - M5 The control switch is connected between PIN1, PIN8 and PIN5
 - M6 The control switch is connected between PIN1, PIN9 and PIN5
 - M7 The control switch is connected between PIN1, PIN8, PIN9 and PIN5

PROGRAM Mode:

- M1 The control switch is connected between PIN8 and PIN5
- M2 The control switch is connected between PIN9 and PIN5
- M3 The control switch is connected between PIN8, PIN9 and PIN5
- M4 The control switch is connected between PIN1 and PIN5
- M5 The control switch is connected between PIN1, PIN8 and PIN5
- M6 The control switch is connected between PIN1, PIN9 and PIN5
- M7 The control switch is connected between PIN1, PIN8, PIN9 and PIN5

Chapter 6 Communication Interface

6.1 RS232 Interface

6.1.1 Description

At present, the widely used serial communication standard is the RS-232 standard, it can also be called the asynchronous serial communication standard, it is used to implement data communication between computers and computers, between computers and peripherals. RS is the English abbreviation of "Recommended Standard" 232 is the standard number. This standard is officially published by the Electronic Industries Association (EIA) in 1969, it specifies that one bit of data is transmitted over a single data line at a time. Most serial port configurations are usually not strictly based on the RS-232 standard; Use 25-pin connector on each port (IMB AT uses 9-pin connector). The most common RS-232 signals are shown in the table below.

Signal	Symbol	25-core connector pin #	9-core connector pin#
Request to Send	RTS	4	7
Clear to Send	CTS	5	8
Data Set Ready	DSR	6	6
Data Carrier Detect	DCD	8	1
Data Terminal Ready	DTR	20	4
Transmit Data	TXD	2	3
Receive Data	RXD	3	2
Grounding	GND	7	5

Table 6-1 RS-232 Signal Table

Like most serial ports in the world, the serial interface of this tester is not strictly based on the RS-232 standard, but only provides a minimal subset. As shown in the following table:

Signal	Symbol	Connector Pin#
Transmit Data	TXD	3
Receive Data	RXD	2
Grounding	GND	5

Table 6-2 RS-232 Signal Subset Table

This is the easiest and the most cost effective way to use serial ports communication. The RS232C connector of this tester uses a 9-core pin type DB socket, and the pin sequence is shown in figure 6-1 below:



Figure 6-1 RS-232 Interface

①Note: The serial port pin definition of this tester is basically the same as the pin definition of the standard 9-core RS232C connector. To avoid electrical shock, turn off the power before plugging or unplugging the connector; Do not short-circuit the output terminals or short-circuit the chassis to avoid damage to the device.

6.1.2 Operation

6.1.2.1 Communication with a Computer

The pin definition of this tester is the same as that of the 9-core connector serial interface pin used by the IMB AT compatible machine. Figure 6-2 shows the RS232 interface.



Figure 6-2 RS232 Interface

Users can use the double-core shielded cable to make three-wire connection cable according to the diagram (the length should be less than 1.5m) or purchase the serial interface cable between the computer and the instrument from our company or purchase the standard DB9 core cable (cross line). When making the connection cable, be careful to short pin 4 and 6, pin 7 and 8 on the computer connector.

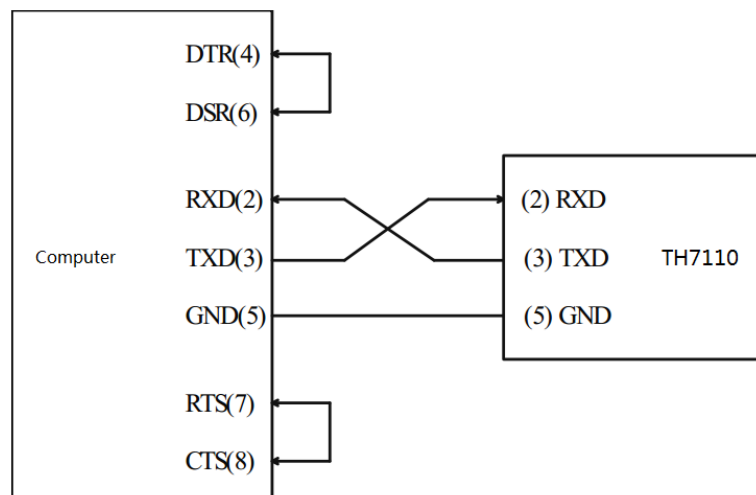

Figure 6-3 RS232 Internal pin wiring diagram

6.1.2.2 Transit and Receive Data Format

The TH7100 series programmable AC power supply uses a full-duplex asynchronous communication transmission method with start and stop bits. The data transmission format of RS-232 is: 8-bit data bit, 1 bit stop bit, there is no parity bit and the end character is <LF> (newline NL, ASCII code is 10).

6.1.2.3 Select Baud Rate

The baud rate is the rate at which the TH7110 communicates with the computer. There are a total of 8 sets of baud rates to choose from, namely 4800, 9600, 14400, 19200, 38400, 57600, 96000, 115200. The default baud rate of the TH7100 series instrument is 9600.

6.2 USB Virtual Serial Port

6.2.1 Description

With the rapid development of PC technology, the RS232 interface is no longer the standard configuration of the PC, and the USB interface is gradually being used more and more widely. The USB interface of the TH7100 series programmable AC power supply caters to this trend, providing users with great convenience and speed, and also has great flexibility for users to use. By installing the USB driver provided by our company, it is convenient to turn the USB virtual serial port into the RS232 interface that users are familiar with. When operating the USB interface, it is as simple and convenient as operating the RS232 serial port. All RS232 interface settings are suitable for the USB virtual serial interface. Figure 6-4 shows the USB interface.



Figure6-4 USB COM

6.2.2 Driver Installation

Users are able to download the TH7100 series USB driver from Tonghui official website www.tonghui.com.cn. If the computer is 32-bit, please use CP210xVCPInstaller_x86.exe to install the USB driver; If it is 64-bit, use

CP210xVCPInstaller_x64.exe. After the driver is installed, connect the TH7100 series instrument to the computer with an USB cable. Open the computer device manager, when the port drop-down list shows CP210x USB to UART Bridge Controller (COM3), indicating connection successful.

6.3 SCPI Communication Commands

SCPI (Standard Commands for Programmable Instruments), also known as the programmable instrument standard command, it defines the way the bus controller communicates with the instrument. It is an ASCII-based instrument command language for test and measurement instruments. SCPI commands are based on a hierarchical structure (also known as a tree system). In this system, related commands are grouped under a common node or root, thus forming a subsystem. The following is part of the DISPlay subsystem to illustrate the tree system.

:DISPlay:PAGE:MEAS

DISPlay is a root level keyword, PAGE is a second level keyword, and MEAS is a third level keyword. A colon (:) is used to separate the command keyword from the next level of keywords.

6.3.1 Command Types

SCPI has two commands: common and subsystem.

1) Common commands are basically unrelated to specific operations and do control the overall functionality of the instrument. For example, reset, query model, all common commands are three-letter commands marked with an asterisk: *RST, *IDN?.

2) Subsystem commands perform the specified instrument functions. They are organized into an inverted tree structure with roots at the top. The following figure shows a portion of a subsystem command tree so you can get commands for different paths. Part command trees are shown in Figure 6-5.

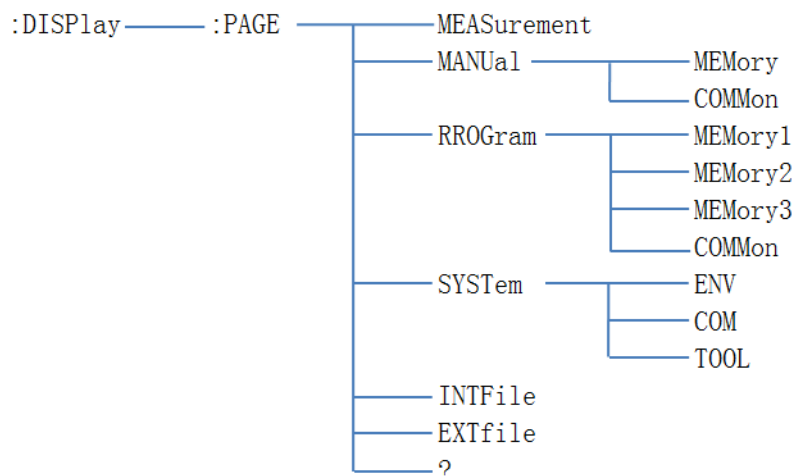

Figure 6-5 Subsystem command tree

6.3.2 Command Syntax

6.3.2.1 Command Key Words and Argument

There are two types of common commands and SCPI commands: command with and without argument. Below are some examples:

*RST	without argument
:FORMat <name>	with argument(name)
:IMMediate	without argument

There should be at least one space between the command keyword and the argument.

1. []

Some command words are placed in square brackets, meaning that these command words are optional. You cannot write this information while writing a program. E.g:

```
:RANGe[:UPPer] <n>
```

This square bracket indicates: UPPer is optional, don't have to use it. Thus the above command can be sent in the following two ways:

```
:RANGe <n> or :RANGe:UPPer <n>
```

Note: Do not use square brackets ([]) when using optional commands.

2. <>

Use angle brackets to indicate a argument type. Angle brackets (<>) are not included when writing a program, for example: :HOLD:STATe

The argument indicates that this is a Boolean type parameter, therefore, if you turn on the HOLD function, you must send an argument command with ON or 1, as below:

```
:HOLD:STATe ON or :HOLD:STATe 1
```

6.3.2.2 Command Separator

1 (:)

The colon is used to separate the command keyword from the next level of keywords.

```
HOLD:STATe ON
```

2 (;)

A semicolon is used to separate multiple commands from the same subsystem.

TRIG: SOUREXT; COUNT 10 has the same effect as sending the following two commands:

```
TRIG:SOUREXT  
TRIG:COUNT 10
```

3 (,)

A comma is used to separate multiple arguments of a command.

APPL:SIN455E3,1.15,0.0

4 (?)

You can query the current value of most parameters by adding a question mark (?) to the command. For example, the following command sets the trigger count to 10:TRIG:COUNT 10. Then, you can query the count value by sending the following command: TRIG:COUNT?

5 Space

Must use a blank character, [TAB] or [space] to separate the parameters from the command keyword.

6 General Command (*)

XXXX The IEEE-488.2 standard defines a common set of commands that perform functions such as reset, self-test, and status operations. For example: *RST.

7 Command Terminator (<NL>)

The command string sent to the instrument must end with a <newline> (<NL>) character. The IEEE-488 EOI (end or identification) information can be treated as an <NL> character, and used to terminate the command string instead of the <NL> character. A <backspace> followed by a <NL> is also possible. Command string termination always resets the current SCPI command path to the root level.

6.3.2.3 Command Abbreviation Rules

- 1) Use below rules to determine the abbreviations for any SCPI commands.
- 2) If the length of the command keyword is less than or equal to four characters, there is no abbreviated form. For example: :AUTO=:AUTO
- 3) If the fourth character of the command keyword is one of v, o, w, e, l, then remove it and all characters following it. For example: :immediate=:imm
- 4) Special rule: The abbreviated form of the following command uses only the first two characters of the keyword: :TCouple=:tc
- 5) If the fourth character of the command keyword is a consonant, leave it and remove all subsequent characters. For example: :format=:form
- 6) If the command contains a query token (?) or an unselectable number in the command keyword, it must be included in the abbreviated form. For example: :delay?=:del?
- 7) The command keywords or characters contained in square brackets ([]) are optional and may not be included in the program code.

6.3.2.4 Command Structure Basic Rules

- 1) Ignore case
Example: FUNC:VOLT:DC=func:volt:dc=Func:Volt:Dc
- 2) Spaces cannot be placed before and after the colon.
Example: : FUNC : VOLT : DC wrong, correct: :FUNC:VOLT:DC
- 3) Commands can be abbreviated or spelled all. Lowercase letters in the command can be omitted.
Example: FUNCtion:VOLTage:DC=FUNC:VOLT:DC
- 4) The command is followed by a question mark (?) to execute a query corresponding to the command.
Example: FUNC?

6.3.3 Common Commands

- 1) *CLS
This command clears the following registers: Standard Event Register, Query Event Register, Status Bit Group Register.
- 2) *ESE?
This command is used to query the value of the standard event enable register. The return value is from 0 to 255.
- 3) *ESR?
This command can be used to read the value of the standard event register. After the command is executed, the value of the standard event register is cleared. The bit definition of the standard event register is the same as the bit definition of the standard event enable register.
- 4) *IDN?
This command is used to query the model number, SN number, and version number of the instrument. For example: Tonghui, TH7110, SHF-888-8888, V1.0.0 Copyright(c) 2017-09-01.
- 5) *OCP?
The OPC bit of the standard event register is set to 1 when all commands preceding this command have been executed. Sending a query command will return the output buffer to "1".
- 6) *RST
This command resets the power supply to the factory setting state.
- 7) *SRE?
This command is used to query the value of the status enable register. When querying the status bit

enable register, the power will return a decimal number, this number is the binary weighted sum of all the bits in the enable register.

8) *STB?

This command can be used to read the value of the status register.

6.3.4 DISPlay Subsystem Commands

DISPlay subsystem commands are mainly used to set the instrument display page.

Character? Is used to query the current page. The command structure is shown in Figure 6-6

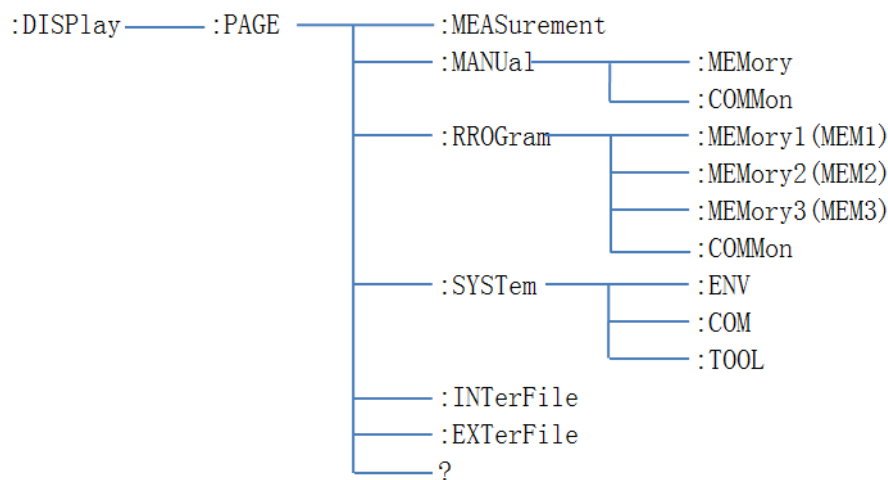

Figure 6-6 DISPlay command structure diagram

■ :DISPlay:PAGE <pagename>

- 1) Command Syntax: :DISPlay:PAGE:MEASurement
 Shorthand for the command: :DISP:PAGE:MEAS
 Command description: Set the display page to the measurement display page

- 2) Command Syntax: :DISPlay:PAGE:MANUal:MEMory
 Shorthand for the command: :DISP:PAGE:MANU:MEM
 Command description: Set the display page to the sequence setting page in manual mode
 Command Syntax: :DISPlay:PAGE:MANUal:COMMon
 Shorthand for the command: :DISP:PAGE:MANU:COMM
 Command description: Set the display page to the general setting page in manual mode

- 3) Command Syntax: :DISPlay:PAGE:PROGram:MEMory1
 Shorthand for the command: :DISP:PAGE:PROG:MEM1
 Command description: Set the display page to: sequence setting page 1 in the programmable mode
 Command Syntax: :DISPlay:PAGE:PROGram:MEMory2
 Shorthand for the command: :DISP:PAGE:PROG:MEM2
 Command description: Set the display page to: sequence setting page 2 in the programmable mode
 Command Syntax: :DISPlay:PAGE:PROGram:MEMory3

Shorthand for the command: :DISP:PAGE:PROG:MEM3

Command description: Set the display page to: sequence setting page 3 in the programmable mode

Command Syntax: :DISPlay:PAGE:PROGram:COMMMon

Shorthand for the command: :DISP:PAGE:PROG:COMM

Command description: Set the display page to: general setting page in program mode

4) Command Syntax: :DISPlay:PAGE:SYSTem:ENV

Shorthand for the command: :DISP:PAGE:SYST:ENV

Command description: Set the display page to: system environment page under system setting

Command Syntax: :DISPlay:PAGE:SYSTem:COM

Shorthand for the command: :DISP:PAGE:SYST:COM

Command description: Set the display page to: system communication page under system setting

Command Syntax: :DISPlay:PAGE:SYSTem:TOOL

Shorthand for the command: :DISP:PAGE:SYST:TOOL

Command description: Set the display page to: system tool page under system setting

5) Command Syntax: :DISPlay:PAGE:INTerFile

Shorthand for the command: :DISP:PAGE:INTF

Command description: Set the display page to: Internal File page

6) Command Syntax: :DISPlay:PAGE:EXTerFile

Shorthand for the command: :DISP:PAGE:EXTF

Command description: Set the display page to: External File page

■ Query Syntax: :DISPlay:PAGE?

Query Return:

MEAS	Currently on the measurement display page
MANUMEM	Currently on the sequence settings page in manual mode
MANUCOMM	Currently on the general settings page in manual mode
PROGMEM1	Currently on sequence setting page 1 in programmable mode
PROGMEM2	Currently on sequence setting page 2 in programmable mode
PROGMEM3	Currently on sequence setting page 3 in programmable mode
PROGCOMM	Currently on general setting page in programmable mode
SYSTEMV	Currently on system environment page under system setting
SYSTCOM	Currently on system communication page under system setting
SYSTTOOL	Currently on system tool page under system setting
INTF	Currently on Internal File page
EXTF	Currently on External File page

6.3.5 :FUNctIon Subsystem Commands

FUNctIon subsystem commands are mainly used to set the test parameters of test function.

Character? can query the current page. The command structure is shown in Figure 6-7

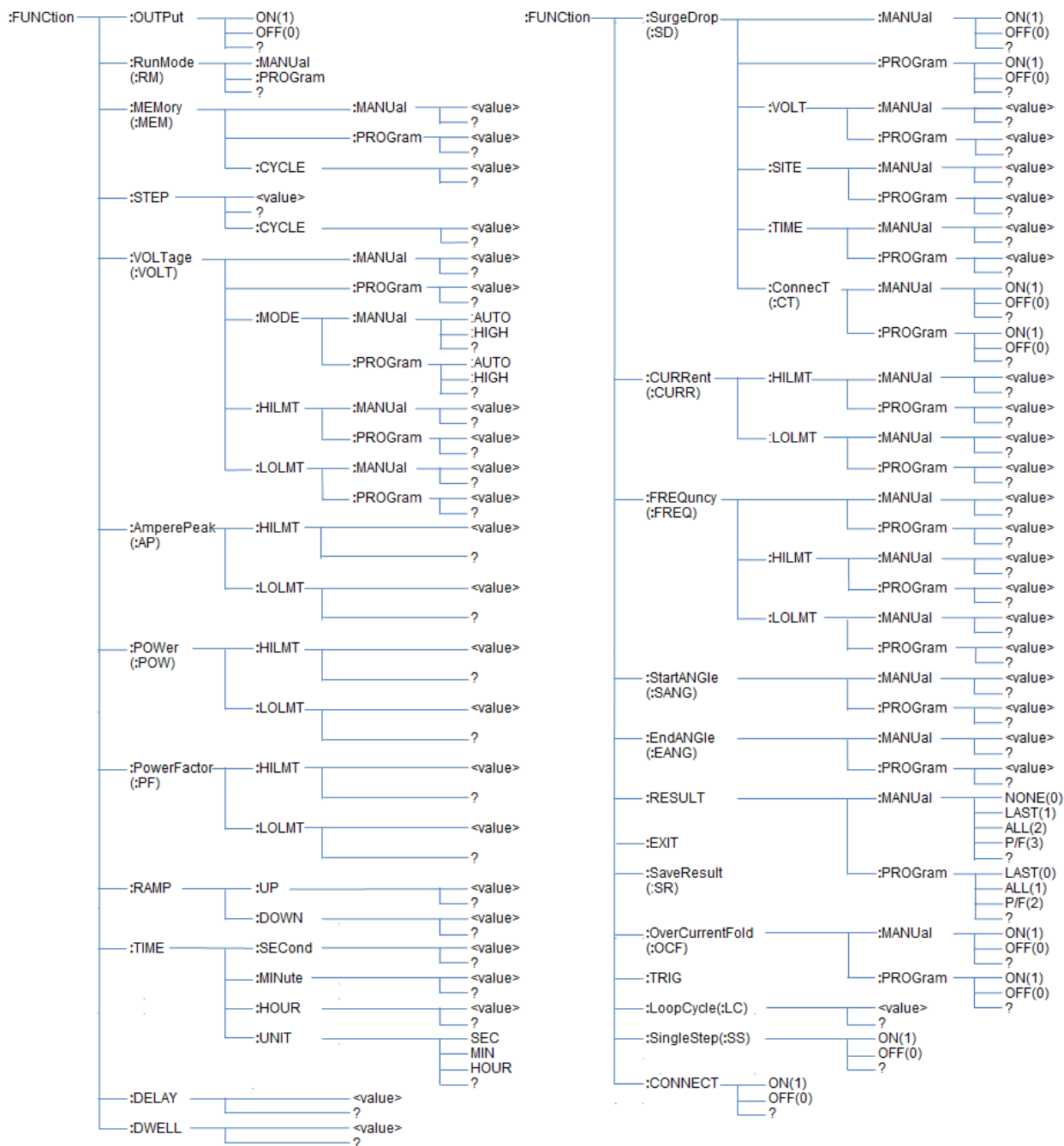

Figure 6-7 FUNCTION Commands Structure Diagram

6.3.5.1 :FUNC:OUTP

- Command Syntax: :FUNCTION:OUTPut ON or :FUNCTION:OUTPut 1
 Shorthand for command: :FUNC:OUTP ON or :FUNC:OUTP 1
 Command description: This command is used to turn on the AC output, this command is only valid under the measurement display page.
- Command Syntax: :FUNCTION:OUTPut OFF or :FUNCTION:OUTPut 0

Shorthand for command: :FUNC:OUTP OFF or :FUNC:OUTP 0

Command description: This command is used to turn off the AC output, this command is only valid under the measurement display page.

■ Command Syntax: :FUNCTION:OUTPut?

Shorthand for command: :FUNC:OUTP?

Command description: This command is used to query the current output status, and the command returns 0 or 1. 0 means the output is off; 1 means the output is on.

6.3.5.2 :FUNC:RM

■ Command Syntax: :FUNCTION:RunMode:MANUal

Shorthand for command: :FUNC:RM:MANU

Command description: This command is used to set the test mode to manual mode. The command is invalid when the output is turned on.

■ Command Syntax: :FUNCTION:RunMode:PROGram

Shorthand for command: :FUNC:RM:PROG

Command description: This command is used to set the test mode to programmable mode. The command is invalid when the output is turned on.

■ Command Syntax: :FUNCTION:RunMode?

Shorthand for command: :FUNC:RM?

Command description: This command is used to query the current test mode. The command returns manual or program. Manual indicates that it is currently in manual mode; program indicates that it is currently in programmable mode.

6.3.5.3 :FUNC:MEM

■ Command Syntax: :FUNCTION:MEMory:MANUal <value>

Shorthand for command: :FUNC:MEM:MANU <value>

Command description: This command is used to set the number of the memory sequence in manual mode. <value> indicates the number value, and the range is 1~50. The command is invalid when the output is turned on.

Command Syntax: :FUNCTION:MEMory:MANUal?

Shorthand for command: :FUNC:MEM:MANU?

Command description: This command is used to query the number value of the memory sequence in manual mode, and returns <value>, its value is equal to 1~50.

■ Command Syntax: :FUNCTION:MEMory:PROGram <value>

Shorthand for command: :FUNC:MEM:PROG <value>

Command description: This command is used to set the number of the memory sequence in the programmable mode. <value> indicates the number value, and the range is 1~50. The command is invalid when the output is turned on.

Command Syntax: :FUNCTION:MEMORY:PROGRAM?

Shorthand for command: :FUNC:MEM:PROG?

Command description: This command is used to query the number of the memory sequence in the programmable mode, and returns <value>, which is equal to 1~50. The command is invalid when the output is turned on.

- Command Syntax: :FUNCTION:MEMORY:CYCLE <value>

Shorthand for command: :FUNC:MEM:CYCLE <value>

Command description: This command is used to set the number of cycles of the current memory sequence in the programmable mode. <value> indicates the value, which ranges from 0 to 999. The command is invalid when the output is turned on.

Command Syntax: :FUNCTION:MEMORY:CYCLE?

Shorthand for command: :FUNC:MEM:CYCLE?

Command description: This command is used to query the number of cycles of the current memory sequence in the programmable mode. Returns <value> with a value equal to 0~999.

6.3.5.4 :FUNC:STEP

- Command Syntax: :FUNCTION:STEP <value>

Shorthand for command: :FUNC:STEP <value>

Command description: This command is used to set the number of the steps in the programmable mode. <value> indicates the number value, and the range is 1~9. The command is invalid when the output is turned on.

Command Syntax: :FUNCTION:STEP?

Shorthand for command: :FUNC:STEP?

Command description: This command is used to query the number value of the step in the programmable mode, and returns <value>, which is equal to 1~9. The command is invalid when the output is turned on.

- Command Syntax: :FUNCTION:STEP:CYCLE <value>

Shorthand for command: :FUNC:STEP:CYCLE <value>

Command description: This command is used to set the number of cycles for the current step in the programmable mode. <value> indicates the value, which ranges from 0 to 999. The command is invalid when the output is turned on.

Command Syntax: :FUNCTION:STEP:CYCLE?

Shorthand for command: :FUNC:STEP:CYCLE?

Command description: This command is used to set the number of cycles for the current step in the programmable mode. <value> indicates the value, which ranges from 0 to 999.

6.3.5.5 :FUNC:VOLT

- Command Syntax: :FUNcTion:VOLtAge:MANUal <value>
Shorthand for command: :FUNC:VOLT:MANU <value>
Command description: This command is used to set the set voltage value in manual mode. <value> indicates the voltage value, and the range is 0.0~300.0V.
Command Syntax: :FUNcTion:VOLtAge:MANUal?
Shorthand for command: :FUNC:VOLT:MANU?
Command description: This command is used to query the set voltage value in the current manual mode, and returns <value>, which is equal to 0.0~300.0V.

- Command Syntax: :FUNcTion:VOLtAge:PROGram <value>
Shorthand for command: :FUNC:VOLT:PROG <value>
Command description: This command is used to set the set voltage value of the current step in the programmable mode. <value> indicates the voltage value, and the range is 0~300V. The command is invalid when the output is turned on.

Command Syntax: :FUNcTion:VOLtAge:PROGram?
Shorthand for command: :FUNC:VOLT:PROG?
Command description: This command is used to query the set voltage value of the current step in the current programmable mode, and returns <value>, which is equal to 0.0~300.0V. The command is invalid when the output is turned on.

6.3.5.6 :FUNC:VOLT:HILMT

- Command Syntax: :FUNcTion:VOLtAge:HIghLiMiT:MANUal <value>
Shorthand for command: :FUNC:VOLT:HILMT:MANU <value>
Command description: This command is used to set the high voltage limit value in manual mode. <value> indicates the high voltage limit value, and the range is 0.0~300.0V.

Command Syntax: :FUNcTion:VOLtAge:HIghLiMiT:MANUal?
Shorthand for command: :FUNC:VOLT:HILMT:MANU?
Command description: This command is used to query the high voltage limit value in manual mode.

- Command Syntax: :FUNcTion:VOLtAge: HIghLiMiT:PROGram <value>
Shorthand for command: :FUNC:VOLT:HILMT:PROG <value>
Command description: This command is used to set the high voltage limit value in the manual mode. <value> indicates the high voltage limit value, and the range is 0.0~300.0V. The command is invalid when the output is turned on.

Command Syntax: :FUNCTION:VOLTage:HighLiMiT:PROGm?

Shorthand for command: :FUNC:VOLT:HILMT:PROG?

Command description: This command is used to query the high voltage limit value in the manual mode.

6.3.5.7 :FUNC:VOLT:LOLMT

- Command Syntax: :FUNCTION:VOLTage:LOWLiMiT:MANUal <value>

Shorthand for command: :FUNC:VOLT:LOLMT:MANU <value>

Command description: This command is used to set the low voltage limit value in the manual mode.
<value> indicates the low voltage limit value, and the range is 0.0~300.0V.

Command Syntax: :FUNCTION:VOLTage:LOWLiMiT:MANUal?

Shorthand for command: :FUNC:VOLT:LOLMT:MANU?

Command description: This command is used to query the low voltage limit value in the manual mode.

- Command Syntax: :FUNCTION:VOLTage:LOWLiMiT:PROGm <value>

Shorthand for command: :FUNC:VOLT:LOLMT:PROG <value>

Command description: This command is used to set the voltage low limit value in programmable mode.
<value> indicates the low voltage limit value, and the range is 0.0~300.0V. The command is invalid when the output is turned on.

Command Syntax: :FUNCTION:VOLTage:LOWLiMiT:PROGm?

Shorthand for command: :FUNC:VOLT:LOLMT:PROG?

Command description: This command is used to query the voltage low limit value in programmable mode.

6.3.5.8 :FUNC:VOLT:MODE

- Command Syntax: :FUNCTION:VOLTage:MODE:MANUal:AUTO

Shorthand for command: :FUNC:VOLT:MODE:MANU:AUTO

Command description: This command is used to set the voltage output in manual mode to AUTO mode.

Command Syntax: :FUNCTION:VOLTage:MODE:MANUal:HIGh

Shorthand for command: :FUNC:VOLT:MODE:MANU:HIGh

Command description: This command is used to set the voltage output in manual mode to HIGH mode.

Command Syntax: :FUNCTION:VOLTage:MODE:MANUal:?

Shorthand for command: :FUNC:VOLT:MODE:MANU:?

Command description: This command is used to query the voltage output mode in manual mode, returning 0 or 1, respectively, referring to auto or high.

- Command Syntax: :FUNCTION:VOLTage:MODE:PROGm:AUTO

Shorthand for command: :FUNC:VOLT:MODE:PROG:AUTO

Command description: This command is used to set the voltage output of the current step in the programmable mode to the AUTO mode. The command is invalid when the output is turned on.

Command Syntax: :FUNction:VOLtagE:MODE:PROG:HIGH

Shorthand for command: :FUNC:VOLT:MODE:PROG: HIGH

Command description: This command is used to set the voltage output of the current step in the programmable mode to the HIGH mode. The command is invalid when the output is turned on.

Command Syntax: :FUNction:VOLtagE:MODE:PROG:?

Shorthand for command: :FUNC:VOLT:MODE:PROG: ?

Command description: This command is used to query the voltage output mode of the current step in the programmable mode, and returns 0 or 1, which refers to auto or high respectively. The command is invalid when the output is turned on.

6.3.5.9 :FUNC:CURR:HILMT

- Command Syntax: :FUNction:CURRent:HighLiMiT:MANUal <value>

Shorthand for command: :FUNC:CURR:HILMT:MAUN <value>

Command description: This command is used to set the current high limit value in manual mode, and <value> indicates the current high limit value. When the set voltage is not greater than 150V, the setting range is 0.000~8.400A; when the set voltage is greater than 150V, the setting range is 0.000~4.200A. The command is invalid when the output is turned on.

Command Syntax: :FUNction:CURRent:HighLiMiT:MANUal?

Shorthand for command: :FUNC:CURR:HILMT:MAUN?

Command description: This command is used to query the current high limit value in the current manual mode, and returns <value>, which is equal to 0.000~8.400.

- Command Syntax: :FUNction:CURRent: HighLiMiT:PROG: <value>

Shorthand for command: :FUNC:CURR:HILMT:PROG <value>

Command description: This command is used to set the current high limit of the current step in the programmable mode, and <value> indicates the current high limit value. When the set voltage is not greater than 150V, the setting range is 0.000~8.400A; when the set voltage is greater than 150V, the setting range is 0.000~4.200A. The command is invalid when the output is turned on.

Command Syntax: :FUNction:CURRent: HighLiMiT:PROG:?

Shorthand for command: :FUNC:CURR:HILMT:PROG?

Command description: This command is used to query the current high limit of the current step in the current programmable mode, and returns <value>, which is equal to

0.000~8.400.

6.3.5.10 :FUNC:CURR:LOLMT

- Command Syntax: :FUNCTION:CURRENT:LOWLIMIT:MANUAL <value>
Shorthand for command: :FUNC:CURR:LOLMT:MAUN <value>
Command description: This command is used to set the current low limit value in manual mode, and <value> indicates the current low limit value. When the set voltage is not greater than 150V, the setting range is 0.000~8.400A; when the set voltage is greater than 150V, the setting range is 0.000~4.200A. The command is invalid when the output is turned on.

Command Syntax: :FUNCTION:CURRENT:LOWLIMIT:MANUAL?

Shorthand for command: :FUNC:CURR:LOLMT:MAUN?

Command description: This command is used to query the current high limit value in the current manual mode, and returns <value>, which is equal to 0.000~8.400.

- Command Syntax: :FUNCTION:CURRENT:LOWLIMIT:PROGRAM <value>
Shorthand for command: :FUNC:CURR:LOLMT:PROG <value>
Command description: This command is used to set the current low limit value of the current step in the programmable mode, and <value> indicates the current low limit value. When the set voltage is not greater than 150V, the setting range is 0.000~8.400A; when the set voltage is greater than 150V, the setting range is 0.000~4.200A. The command is invalid when the output is turned on.

Command Syntax: :FUNCTION:CURRENT:LOWLIMIT:PROGRAM?

Shorthand for command: :FUNC:CURR:LOLMT:PROG?

Command description: This command is used to query the current low limit of the current step in the programmable mode, and returns <value>, which is equal to 0.000~8.400.

6.3.5.11 :FUNC:FREQ

- Command Syntax: :FUNCTION:FREQUENCY:MANUAL <value>
Shorthand for command: :FUNC:FREQ:MANU <value>
Command description: This command is used to set the frequency value in manual mode, and <value> represents the output frequency value. Its setting range is 45.0~500Hz. When the frequency is less than 100 Hz, the resolution is 0.1 Hz; when the frequency is not less than 100 Hz, the resolution is 1 Hz.

Command Syntax: :FUNCTION:FREQUENCY:MANUAL?

Shorthand for command: :FUNC:FREQ:MANU?

Command description: This command is used to query the output frequency value in manual mode, and

returns <value>, which is equal to 45.0~500Hz.

- Command Syntax: :FUNction:FREQuency:PROGram <value>

Shorthand for command: :FUNC:FREQ:PROG <value>

Command description: This command is used to set the output frequency value of the current step in the programmable mode, and <value> indicates the output frequency value. Its setting range is 45.0~500Hz. When the frequency is less than 100 Hz, the resolution is 0.1 Hz; when the frequency is not less than 100 Hz, the resolution is 1 Hz. The command is invalid when the output is turned on.

Command Syntax: :FUNction:FREQuency:PROGAm?

Shorthand for command: :FUNC:FREQ:PROG?

Command description: This command is used to query the output frequency value of the current step in the programmable mode, and returns <value>, which is equal to 45.0~500Hz.

6.3.5.12 :FUNC:FREQ:HILMT

- Command Syntax: :FUNction:FREQuency:HighLiMiT:MANUal <value>

Shorthand for command: :FUNC:FREQ:HILMT:MANU <value>

Command description: This command is used to set the high limit of the output frequency in manual mode, and <value> is the high limit of the output frequency. Its setting range is 45.0~500Hz. When the frequency is less than 100 Hz, the resolution is 0.1 Hz; when the frequency is not less than 100 Hz, the resolution is 1 Hz.

Command Syntax: :FUNction:FREQuency:HighLiMiT:MANUal?

Shorthand for command: :FUNC:FREQ:HILMT:MANU?

Command description: This command is used to query the high limit of the output frequency in manual mode, and returns <value>, which is equal to 45.0~500Hz.

- Command Syntax: :FUNction:FREQuency:HighLiMiT:PROGAm <value>

Shorthand for command: :FUNC:FREQ:HILMT:PROG <value>

Command description: This command is used to set the high limit of the output frequency of the current step in the programmable mode, and <value> indicates the high limit of the output frequency. Its setting range is 45.0~500Hz. When the frequency is less than 100 Hz, the resolution is 0.1 Hz; when the frequency is not less than 100 Hz, the resolution is 1 Hz. The command is invalid when the output is turned on.

Command Syntax: :FUNction:FREQuency:HighLiMiT:PROGAm?

Shorthand for command: :FUNC:FREQ:HILMT:PROG?

Command description: This command is used to query the upper limit of the output frequency of the current step in the programmable mode, and returns <value>, which is equal to 45.0~500Hz.

6.3.5.13 :FUNC:FREQ:LOLMT

- Command Syntax: :FUNCTION:FREQUENCY:LOWLIMIT:MANUAL <value>

Shorthand for command: :FUNC:FREQ:LOLMT:MANU <value>

Command description: This command is used to set the low limit of the output frequency in manual mode, and <value> is the low limit of the output frequency. Its setting range is 45.0~500Hz. When the frequency is less than 100 Hz, the resolution is 0.1 Hz; when the frequency is not less than 100 Hz, the resolution is 1 Hz.

Command Syntax: :FUNCTION:FREQUENCY:LOWLIMIT:MANUAL?

Shorthand for command: :FUNC:FREQ:LOLMT:MANU?

Command description: This command is used to query the low limit of the output frequency in manual mode, and returns <value>, which is equal to 45.0~500Hz.

- Command Syntax: :FUNCTION:FREQUENCY:LOWLIMIT:PROGRAM <value>

Shorthand for command: :FUNC:FREQ:LOLMT:PROG <value>

Command description: This command is used to set the low limit of the output frequency of the current step in the programmable mode, and <value> indicates the low limit of the output frequency. Its setting range is 45.0~500Hz. When the frequency is less than 100 Hz, the resolution is 0.1 Hz; when the frequency is not less than 100 Hz, the resolution is 1 Hz. The command is invalid when the output is turned on.

Command Syntax: :FUNCTION:FREQUENCY:LOWLIMIT:PROGRAM?

Shorthand for command: :FUNC:FREQ:LOLMT:PROG?

Command description: This command is used to query the low limit of the output frequency of the current step in the programmable mode, and returns <value>, which is equal to 45.0~500Hz.

6.3.5.14 :FUNC:CONNECT

- Command Syntax: :FUNCTION:CONNECT ON or :FUNCTION:CONNECT 1

Shorthand for command: :FUNC:CONNECT ON or :FUNC:CONNECT 1

Command description: This command is used to turn on the step connection of the current step. The command is invalid when the output is turned on.

Command Syntax: :FUNCTION:CONNECT OFF or :FUNCTION:CONNECT 0

Shorthand for command: :FUNC:CONNECT OFF or :FUNC:CONNECT 0

Command description: This command is used to turn off the step connection of the current step. The command is invalid when the output is turned on.

Command Syntax: :FUNCTION:CONNECT?

Shorthand for command: :FUNC:CONNECT?

Command description: This command is used to query the status of the step connection of the current

step. Returns 0 when the step connection is turned off, and returns 1 when the step connection is turned on.

6.3.5.15 :FUNC:AP:HILMT

- Command Syntax: :FUNCTION:AmperePeak:HighLiMiT <value>

Shorthand for command: :FUNC:AP:HILMT <value>

Command description: This command is used to set the peak current high limit value of the current step in the programmable mode, and <value> indicates the peak current high limit value. When the voltage mode is "AUTO" and the voltage is less than 150V, the range is 0.0~33.6A; when the voltage mode is "AUTO" and the voltage is greater than 150V or the voltage mode is "HIGH", the range is 0.0~16.8A. When this parameter is set to 0.0, this function is turned off. The command is invalid when the output is turned on.

Command Syntax: :FUNCTION:AmperePeak:HighLiMiT?

Shorthand for command: :FUNC:AP:HILMT?

Command description: This command is used to query the peak current high limit of the current step in the programmable mode, and returns <value>, which is equal to 0.0~33.6.

6.3.5.16 :FUNC:AP:LOLMT

- Command Syntax: :FUNCTION:AmperePeak:LowLiMiT <value>

Shorthand for command: :FUNC:AP:LOLMT <value>

Command description: This command is used to set the peak current low limit value of the current step in the programmable mode, and <value> indicates the peak current low limit value. When the voltage mode is "AUTO" and the voltage is less than 150V, the range is 0.0~33.6A; when the voltage mode is "AUTO" and the voltage is greater than 150V or the voltage mode is "HIGH", the range is 0.0~16.8A. When this parameter is set to 0.0, this function is turned off. The command is invalid when the output is turned on.

Command Syntax: :FUNCTION:AmperePeak:LowLiMiT?

Shorthand for command: :FUNC:AP:LOLMT?

Command description: This command is used to query the peak current low limit value of the current step in the programmable mode, and returns <value>, which is equal to 0.0~33.6.

6.3.5.17 :FUNC:POW:HILMT

- Command Syntax: :FUNCTION:POWer:HighLiMiT <value>

Shorthand for command: :FUNC:POW:HILMT <value>

Command description: This command is used to set the power high limit of the current step in the programmable mode. <value> represents the peak power high limit value, and the range is 0~1000W. The command is invalid when the output is turned on.

Command Syntax: :FUNction:POWer:HighLiMiT?

Shorthand for command: :FUNC:POW:HILMT?

Command description: This command is used to query the power high limit of the current step in the programmable mode, and returns <value>, which is equal to 0~1000W. The command is invalid when the output is turned on.

6.3.5.18 :FUNC:POW:LOLMT

- Command Syntax: :FUNction:POWer:LOwLiMiT <value>

Shorthand for command: :FUNC:POW:LOLMT <value>

Command description: This command is used to set the power low limit value of the current step in the programmable mode. <value> indicates the peak power low limit value, and the range is 0~1000W. The command is invalid when the output is turned on.

Command Syntax: :FUNction:POWer:LOwLiMiT?

Shorthand for command: :FUNC:POW:LOLMT?

Command description: This command is used to query the power low limit of the current step in the programmable mode, and returns <value>, which is equal to 0~1000W. The command is invalid when the output is turned on.

6.3.4.19 :FUNC:PF:HILMT

- Command Syntax: :FUNction:PowerFactor:HighLiMiT <value>

Shorthand for command: :FUNC:PF:HILMT <value>

Command description: This command is used to set the high limit of the power factor of the current step in the programmable mode. <value> represents the high limit of the peak power factor, and its range is 0~1000W. The command is invalid when the output is turned on.

Command Syntax: :FUNction:PowerFactor:HighLiMiT?

Shorthand for command: :FUNC:PF:HILMT?

Command description: This command is used to query the high limit of the power factor of the current step in the programmable mode, and returns <value>, which is equal to 0~1000W. The command is invalid when the output is turned on.

6.3.5.20 :FUNC:PF:LOLMT

- Command Syntax: :FUNCTION:PowerFactor:LOWLiMiT <value>

Shorthand for command: :FUNC:PF:LOLMT <value>

Command description: This command is used to set the power factor low limit value of the current step in the programmable mode, and <value> indicates the peak power factor low limit value, which ranges from 0 to 1000W. The command is invalid when the output is turned on.

Command Syntax: :FUNCTION:PowerFactor:LOWLiMiT?

Shorthand for command: :FUNC:PF:LOLMT?

Command description: This command is used to query the low limit of the power factor of the current step in the programmable mode, and returns <value>, which is equal to 0~1000W. The command is invalid when the output is turned on.

6.3.5.21 :FUNC:DELAY

- Command Syntax: :FUNCTION:DELAY <value>

Shorthand for command: :FUNC:DELAY <value>

Command description: This command is used to set the delay determination time of the current step in the programmable mode.<value> indicates the delay determination time. When the unit is second, the range is 0.1~999.9s; when the unit is minute, the range is 0.1~999.9m; when the unit is time, the range is 0.1~999.9h. The command is invalid when the output is turned on.

Command Syntax: :FUNCTION:DELAY?

Shorthand for command: :FUNC:DELAY?

Command description: This command is used to query the delay determination time of the current step in the programmable mode. Returns <value>, when the unit is second, its value is 0.1~999.9s; when the unit is minute, its value is 0.1~999.9m; when the unit is time, its value is 0.1~999.9h. The command is invalid when the output is turned on.

6.3.5.22 :FUNC:DWELL

- Command Syntax: :FUNCTION:DWELL <value>

Shorthand for command: :FUNC:DWELL <value>

Command description: This command is used to set the test time of the current step in the programmable mode. <value> indicates the test time. When the unit is second, the range is 0.1-999.9s; when the unit is minute, the range is 0.1-999.9m; when the unit is time, the range is 0.1-999.9h. The command is invalid when the output is turned on.

Command Syntax: :FUNcTion:DWELL?

Shorthand for command: :FUNC:DWELL?

Command description: This command is used to query the test time of the current step in the programmable mode. Returns <value>, when the unit is second, its value is 0.1~999.9s; when the unit is minute, its value is 0.1~999.9m; when the unit is time, its value is 0.1~999.9h. The command is invalid when the output is turned on.

6.3.5.23 :FUNC:RAMP

- Command Syntax: :FUNcTion:RAMP:UP <value>

Shorthand for command: :FUNC:RAMP:UP <value>

Command description: This command is used to set the ramp up time of the current step in the programmable mode. <value> indicates the ramp up time, which ranges from 0.0 to 999.9s. The command is invalid when the output is turned on.

Command Syntax: :FUNcTion:RAMP:UP?

Shorthand for command: :FUNC:RAMP:UP?

Command description: This command is used to query the ramp up time of the current step in the programmable mode. Returns <value> with a value of 0.0~999.9s. The command is invalid when the output is turned on.

- Command Syntax: :FUNcTion:RAMP:DOWN <value>

Shorthand for command: :FUNC:RAMP:DOWN <value>

Command description: This command is used to set the ramp down time of the current step in the programmable mode. <value> indicates the ramp down time, which ranges from 0.0 to 999.9s. The command is invalid when the output is turned on.

Command Syntax: :FUNcTion:RAMP:DOWN?

Shorthand for command: :FUNC:RAMP:DOWN?

Command description: This command is used to query the ramp down time of the current step in the programmable mode. Returns <value> with a value of 0.0~999.9s. The command is invalid when the output is turned on.

6.3.5.24 :FUNC:TIME

- Command Syntax: :FUNcTion:TIME:SECond <value>

Shorthand for command: :FUNC:TIME:SEC <value>

Command description: This command is used to set the second value of the timer in manual mode. <value> represents the timer seconds value, which ranges from 0 to 59.

Command Syntax: :FUNcTion:TIME:SECond?

Shorthand for command: :FUNC: TIME:SEC?

Command description: This command is used to query the seconds value of the timer in manual mode. It returns <value> and its value is equal to 0~59.

- Command Syntax: :FUNCtion:TIME:MINute <value>

Shorthand for command: :FUNC:TIME:MIN <value>

Command description: This command is used to set the score of the timer in manual mode. <value> indicates the timer score, which ranges from 0 to 59.

Command Syntax: :FUNCtion:TIME:MINute?

Shorthand for command: :FUNC:TIME:MIN?

Command description: This command is used to query the score of the timer in manual mode, and returns <value>, which is equal to 0~59.

- Command Syntax: :FUNCtion:TIME:HOuR <value>

Shorthand for command: :FUNC:TIME: HOuR <value>

Command description: This command is used to set the value when the timer is in manual mode. <value> indicates the timer value, which ranges from 0 to 99.

Command Syntax: :FUNCtion:TIME:HOuR?

Shorthand for command: :FUNC:TIME: HOuR?

Command description: This command is used to query the value of the timer in manual mode. It returns <value> and its value is equal to 0~99.

- Command Syntax: :FUNCtion:TIME:UNIT:SECond

Shorthand for command: :FUNC:TIME: UNIT:SEC

Command description: This command is used to set the delay determination time and measurement time in the programmable mode in seconds. The command is invalid when the output is turned on.

Command Syntax: :FUNCtion:TIME:UNIT:MINute

Shorthand for command: :FUNC:TIME: UNIT:MIN

Command description: This command is used to set the unit as minute for the delay judgment time and measurement time in the programmable mode. The command is invalid when the output is turned on.

Command Syntax: :FUNCtion:TIME:UNIT:HOuR

Shorthand for command: :FUNC:TIME: UNIT:HOuR

Command description: This command is used to set the unit as hour for the delay judgment time and measurement time in the programmable mode. The command is invalid when the output is turned on.

Command Syntax: :FUNCtion:TIME:UNIT:?

Shorthand for command: :FUNC:TIME: UNIT:?

Command description: This command is used to query the time unit of the current step in the programmable mode. When the unit is second, it returns 0; when the unit is

minute, it returns 1; when the unit is time, it returns 2. The command is invalid when the output is turned on.

6.3.5.25 :FUNC:SD

- Command Syntax: :FUNCTION:SurgeDrop:MANUal ON or :FUNCTION:SurgeDrop:MANUal 1
Shorthand for command: :FUNC:SD:MANU ON or :FUNC:SD:MANU 1
Command description: This command is used to enable the surge drop function in manual mode. The command is invalid when the output is turned on.

Command Syntax: :FUNCTION:SurgeDrop:MANUal OFF or :FUNCTION:SurgeDrop:MANUal 0
Shorthand for command: :FUNC:SD:MANU OFF or :FUNC:SD:MANU 0
Command description: This command is used to turn off the surge drop function in manual mode. The command is invalid when the output is turned on.

Command Syntax: :FUNCTION:SurgeDrop:MANUal?
Shorthand for command: :FUNC:SD:MANU?
Command description: This command is used to query the state of the surge drop in manual mode.

Command Syntax: :FUNCTION:SurgeDrop:PROGram ON or :FUNCTION:SurgeDrop:PROGram 1
Shorthand for command: :FUNC:SD:PROG ON or :FUNC:SD:PROG 1
Command description: This command is used to enable the surge drop at the current step in the programmable mode. The command is invalid when the output is turned on.

Command Syntax: :FUNCTION:SurgeDrop:PROGram OFF or :FUNCTION:SurgeDrop:PROGram 0
Shorthand for command: :FUNC:SD:PROG OFF or :FUNC:SD:PROG 0
Command description: This command is used to turn off the surge drop at the current step in the programmable mode. The command is invalid when the output is turned on.

Command Syntax: :FUNCTION:SurgeDrop:PROGram?
Shorthand for command: :FUNC:SD:PROG?
Command description: This command is used to query the state of the surge drop at the current step in the programmable mode. The command is invalid when the output is turned on.

- Command Syntax: :FUNCTION:SurgeDrop:VOLT:MANUal <value>
Shorthand for command: :FUNC:SD: VOLT:MANU <value>
Command description: This command is used to set the voltage value of the surge drop in manual mode. <value> indicates the value of the glitch trap voltage, ranging from 0.0 to 300.0V.

Command Syntax: :FUNCTION:SurgeDrop:VOLT:MANUal?
Shorthand for command: :FUNC:SD: VOLT:MANU?
Command description: This command is used to query the voltage value of the surge drop in manual mode. Returns <value> with a value equal to 0.0~300.0V.

Command Syntax: :FUNCTION:SurgeDrop:VOLT:PROGram <value>

Shorthand for command: :FUNC:SD:VOLT:PROG <value>

Command description: This command is used to set the voltage value of the surge drop at the current step in the programmable mode. <value> indicates the value of the surge drop voltage, ranging from 0.0 to 300.0V. The command is invalid when the output is turned on.

Command Syntax: :FUNCTION:SurgeDrop:VOLT:PROG?

Shorthand for command: :FUNC:SD:VOLT:PROG?

Command description: This command is used to query the voltage value of the surge drop at the current step in the programmable mode. Returns <value> with a value equal to 0.0~300.0V. The command is invalid when the output is turned on.

■ Command Syntax: :FUNCTION:SurgeDrop:SITE:MANUal <value>

Shorthand for command: :FUNC:SD:SITE:MANU <value>

Command description: This command is used to set the position where the surge drop appears in manual mode. <value> indicates the time at which the glitch trap appears, and its range is 0 to 20 ms.

Command Syntax: :FUNCTION:SurgeDrop:SITE:MANUal?

Shorthand for command: :FUNC:SD:SITE:MANU?

Command description: This command is used to query the location of the surge drop in manual mode. Returns <value> with a value equal to 0~20.

Command Syntax: :FUNCTION:SurgeDrop:SITE:PROG <value>

Shorthand for command: :FUNC:SD:SITE:PROG <value>

Command description: This command is used to set the position of the surge drop in the current step in the programmable mode. <value> indicates the time at which the surge drop appears, ranging from 0 to 20 ms. The command is invalid when the output is turned on.

Command Syntax: :FUNCTION:SurgeDrop:SITE:PROG?

Shorthand for command: :FUNC:SD:SITE:PROG?

Command description: This command is used to set the position of the surge drop in the current step in the programmable mode. Returns <value> with a value equal to 0~20. The command is invalid when the output is turned on.

■ Command Syntax: :FUNCTION:SurgeDrop:TIME:MANUal <value>

Shorthand for command: :FUNC:SD:TIME:MANU <value>

Command description: This command is used to set the time width of the glitch trap in manual mode. <value> indicates the time width of the glitch trap, which ranges from 0 to 20 ms.

Command Syntax: :FUNCTION:SurgeDrop:TIME:MANUal?

Shorthand for command: :FUNC:SD:TIME:MANU?

Command description: This command is used to query the time width of the surge drop in manual mode. Returns <value> with a value equal to 0~20.

Command Syntax: :FUNCTION:SurgeDrop:TIME:PROG <value>

Shorthand for command: :FUNC:SD:TIME:PROG <value>

Command description: This command is used to set the time width of the surge drop at the current step in the programmable mode. <value> indicates the time width of the surge drop, ranging from 0 to 20 ms. The command is invalid when the output is turned on.

Command Syntax: :FUNction:SurgeDrop:TIME:PROGm?

Shorthand for command: :FUNC:SD:TIME:PROG?

Command description: This command is used to set the time width of the surge drop at the current step in the programmable mode. Returns <value> with a value equal to 0~20. The command is invalid when the output is turned on.

- Command Syntax: :FUNction:SurgeDrop:Connect:MANUal ON or :FUNction:SurgeDrop: Connect:MANUal 1

Shorthand for command: :FUNC:SD:CT:MANU ON or :FUNC:SD:CT:MANU 1

Command description: This command is used to turn on the SD connection of the current memory sequence. The command is invalid when the output is turned on.

Command Syntax: :FUNction:SurgeDrop:Connect:MANUal OFF or :FUNction:SurgeDrop: Connect:MANUal 0

Shorthand for command: :FUNC:SD:CT:MANU OFF or :FUNC:SD:CT:MANU 0

Command description: This command is used to turn off the SD connection of the current memory sequence. The command is invalid when the output is turned on.

Command Syntax: :FUNction:SurgeDrop:Connect:MANUal?

Shorthand for command: :FUNC:SD:CT:MANU?

Command description: This command is used to query the status of the SD connection switch of the current memory sequence. Returns 0 when the step connection is turned off, and returns 1 when the step connection is turned on.

- Command Syntax: :FUNction:SurgeDrop:Connect:PROGm ON

or :FUNction:SurgeDrop:Connect:PROGm 1

Shorthand for command: :FUNC:SD:CT:PROG ON or :FUNC:SD:CT:PROG 1

Command description: This command is used to turn on the step connection of the current step. The command is invalid when the output is turned on.

Command Syntax: :FUNction:SurgeDrop:Connect:PROGm OFF

or :FUNction:SurgeDrop:Connect:PROGm 0

Shorthand for command: :FUNC:SD:CT:PROG OFF or :FUNC:SD:CT:PROG 0

Command description: This command is used to turn off the step connection of the current step. The command is invalid when the output is turned on.

Command Syntax: :FUNction:SurgeDrop:Connect:PROGm?

Shorthand for command: :FUNC:SD:CT:PROG?

Command description: This command is used to query the step connection switch status of the current step. Returns 0 when the step connection is turned off, and returns 1 when the step connection is turned on.

6.3.5.26 :FUNC:SANG

- Command Syntax: :FUNCTION:StartANGLE:MANUal <value>

Shorthand for command: :FUNC:SANG:MANU <value>

Command description: This command is used to set the starting angle in manual mode, <value> is the starting angle, and the range is 0~359° .

Command Syntax: :FUNCTION:StartANGLE:MANUal?

Shorthand for command: :FUNC:SANG:MANU?

Command description: This command is used to query the starting angle in manual mode and returns <value>, which is equal to 0~359.

Command Syntax: :FUNCTION:StartANGLE:PROGram <value>

Shorthand for command: :FUNC:SANG:PROG <value>

Command description: This command is used to set the starting angle of the current step in the programmable mode. <value> indicates the starting angle, and the range is 0~359° . The command is invalid when the output is turned on.

Command Syntax: :FUNCTION:StartANGLE:PROGram?

Shorthand for command: :FUNC:SANG:PROG?

Command description: This command is used to query the starting angle of the current step in the programmable mode, and returns <value>, which is equal to 0~359. The command is invalid when the output is turned on.

6.3.5.27 :FUNC:EANG

- Command Syntax: :FUNCTION:EndANGLE:MANUal <value>

Shorthand for command: :FUNC:EANG:MANU <value>

Command description: This command is used to set the end angle in manual mode, and <value> indicates the end angle, ranging from 0 to 359° .

Command Syntax: :FUNCTION:EndANGLE:MANUal?

Shorthand for command: :FUNC:EANG:MANU?

Command description: This command is used to query the end angle in manual mode, and returns <value>, which is equal to 0~359.

Command Syntax: :FUNCTION:EndANGLE:PROGram <value>

Shorthand for command: :FUNC:EANG:PROG <value>

Command description: This command is used to set the end angle of the current step in the programmable mode. <value> indicates the end angle, and the range is 0~359°. The command is invalid when the output is turned on.

Command Syntax: :FUNCTION:EndANGLE:PROG?

Shorthand for command: :FUNC:EANG:PROG?

Command description: This command is used to query the termination angle of the current step in the programmable mode, and returns <value>, which is equal to 0~359. The command is invalid when the output is turned on.

6.3.5.28 :FUNC:RESULT

- Command Syntax: :FUNCTION:RESULT:MANUal NONE or :FUNCTION:RESULT:MANUal 0

Shorthand for command: :FUNC:RESULT:MANU NONE or :FUNC:RESULT:MANU 0

Command description: This command is used to set the result display mode to NONE in manual mode.

Command Syntax: :FUNCTION:RESULT:MANUal LAST or :FUNCTION:RESULT:MANUal 1

Shorthand for command: :FUNC:RESULT:MANU LAST or :FUNC:RESULT:MANU 1

Command description: This command is used to set the result display mode to LAST in manual mode.

Command Syntax: :FUNCTION:RESULT:MANUal ALL or :FUNCTION:RESULT:MANUal 2

Shorthand for command: :FUNC:RESULT:MANU ALL or :FUNC:RESULT:MANU 2

Command description: This command is used to set the result display mode to ALL in manual mode.

Command Syntax: :FUNCTION:RESULT:MANUal P/F or :FUNCTION:RESULT:MANUal 3

Shorthand for command: :FUNC:RESULT:MANU P/F or :FUNC:RESULT:MANU 3

Command description: This command is used to set the result display mode to P/F in manual mode.

Command Syntax: :FUNCTION:RESULT:MANUal?

Shorthand for command: :FUNC:RESULT:MANU?

Command description: This command is used to query the result display mode in manual mode. When the result display mode is NONE, it returns 0; when the result display mode is LAST, it returns 1; when the result display mode is ALL, it returns 2; when the result display mode is P/F, return 3.

- Command Syntax: :FUNCTION:RESULT:PROGram LAST or :FUNCTION:RESULT:PROGram 0

Shorthand for command: :FUNC:RESULT:PROG LAST or :FUNC:RESULT:PROG 0

Command description: This command is used to set the result display mode to LAST in the program mode. The command is invalid when the output is turned on.

Command Syntax: :FUNCTION:RESULT:PROGram ALL or :FUNCTION:RESULT:PROGram 1

Shorthand for command: :FUNC:RESULT:PROG ALL or :FUNC:RESULT:PROG 1

Command description: This command is used to set the result display mode to ALL in the program mode. The command is invalid when the output is turned on.

Command Syntax: :FUNction:RESuLT:PROGrama P/F or :FUNction:RESuLT:PROGrama 2

Shorthand for command: :FUNc:RESuLT:PROG P/F or :FUNc:RESuLT:PROG 2

Command description: This command is used to set the result display mode to P/F in the program mode.
The command is invalid when the output is turned on.

Command Syntax: :FUNction:RESuLT:PROGrama?

Shorthand for command: :FUNc:RESuLT:PROG?

Command description: This command is used to query the result display mode in the programmable mode. When the result display mode is LAST, it returns 0; when the result display mode is ALL, it returns 1; when the result display mode is P/F, it returns 2. The command is invalid when the output is turned on.

6.3.5.29 :FUNC:EXIT

■ Command Syntax: :FUNction:EXIT

Shorthand for command: :FUNc:EXIT

Command description: This command is used to exit the result display state. The command is invalid when the output is turned on.

6.3.5.30 :FUNC:SR

■ Command Syntax: :FUNction:SaveResult

Shorthand for command: :FUNc:SR

Command description: This command is used to save the test results when the result display mode is ALL.
The command is invalid when the output is turned on.

6.3.5.31 :FUNC:OCF

■ Command Syntax: :FUNction:OverCurrentFold:MANUal ON

or :FUNction:OverCurrentFold:MANUal 1

Shorthand for command: :FUNc:OCF:MANU ON or :FUNc:OCF:MANU 1

Command description: This command is used to turn on the over current fold function in manual mode.
The command is invalid when the output is turned on.

Command Syntax: :FUNction:OverCurrentFold:MANUal OFF

or :FUNction:OverCurrentFold:MANUal 0

Shorthand for command: :FUNc:OCF:MANU OFF or :FUNc:OCF:MANU 0

Command description: This command is used to turn off the over current fold function in manual mode. The command is invalid when the output is turned on.

Command Syntax: :FUNCTION:OverCurrentFold:MANUal?

Shorthand for command: :FUNC:OCF:MANU?

Command description: This command is used to query the state of over current fold in manual mode. Returns 1 when the over current fold function is on, and 0 when the over current fold function is off.

Command Syntax: :FUNCTION:OverCurrentFold:PROGram ON

or :FUNCTION:OverCurrentFold:PROGram 1

Shorthand for command: :FUNC:OCF:PROG ON or :FUNC:OCF:PROG 1

Command description: This command is used to turn on the over current fold function in the programmable mode. Command is invalid when output is turned on

Command Syntax: :FUNCTION:OverCurrentFold:PROGram OFF

or :FUNCTION:OverCurrentFold:PROGram 0

Shorthand for command: :FUNC:OCF:PROG OFF or :FUNC:OCF:PROG 0

Command description: This command is used to turn off the over current fold function in the programmable mode. Command is invalid when output is turned on

Command Syntax: :FUNCTION:OverCurrentFold:PROGram?

Shorthand for command: :FUNC:OCF:PROG?

Command description: This command is used to query the state of over current fold in the programmable mode. Returns 1 when the over current fold function is on, and 0 when the over current fold function is off. Command is invalid when output is turned on

6.3.5.32 :FUNC:TRIG

■ Command Syntax: :FUNCTION:TRIG

Shorthand for command: :FUNC:TRIG

Command description: This command is used to manually trigger a surge drop. Command is invalid when output is turned on

6.3.5.33 :FUNC:LC

■ Command Syntax: :FUNCTION:LoopCycle <value>

Shorthand for command: :FUNC:LC <value>

Command description: This command is used to set the total number of cycles of the memory sequence in the programmable mode. <value> indicates the total number of cycles of the memory sequence, ranging from 0 to 999.

Command Syntax: :FUNCTION:LoopCycle?

Shorthand for command: :FUNC:LC?

Command description: This command is used to query the total number of cycles of the memory

sequence in the programmable mode. Returns <value> with a value equal to 0~999.

6.3.5.34 :FUNC: SS

- Command Syntax: :FUNCTION:SingleStep ON or :FUNCTION:SingleStep 1

Shorthand for command: :FUNC:SS ON or :FUNC:SS 1

Command description: This command is used to turn on the single step test function in the programmable mode. The command is invalid when the output is turned on.

Command Syntax: :FUNCTION:SingleStep OFF or :FUNCTION:SingleStep 0

Shorthand for command: :FUNC:SS OFF or :FUNC:SS 0

Command description: This command is used to turn off the single step test function in the programmable mode. The command is invalid when the output is turned on.

Command Syntax: :FUNCTION:SingleStep?

Shorthand for command: :FUNC:SS?

Command description: This command is used to query the single-step test status in the programmable mode. Returns 1 when the single step test function is turned on and 0 when the single step test function is turned off.

6.3.5.35 :FUNC: VOLT:LMT

- Command Syntax: :FUNCTION:VOLTage:LlMT <value>

Shorthand for command: :FUNC:VOLT:LMT <value>

Command description: This command is used to set the output voltage limit protection in manual mode. <value> indicates the voltage limit value, ranging from 5.0 to 50.0V. This value represents the allowable difference between the set voltage and the output voltage.

Command Syntax: :FUNCTION:VOLTage:LlMT?

Shorthand for command: :FUNC:VOLT:LMT ?

Command description: This command is used to query the voltage output limit value in manual mode, and returns <value>, which is equal to 5.0~50.0.

6.3.6 FETCH Subsystem Commands

The FETCH subsystem command is mainly used to query the values of output parameters such as voltage, current, power, ampere peak, power factor, and crest factor in manual mode. The FETCH subsystem command structure is shown in Figure 6-8.

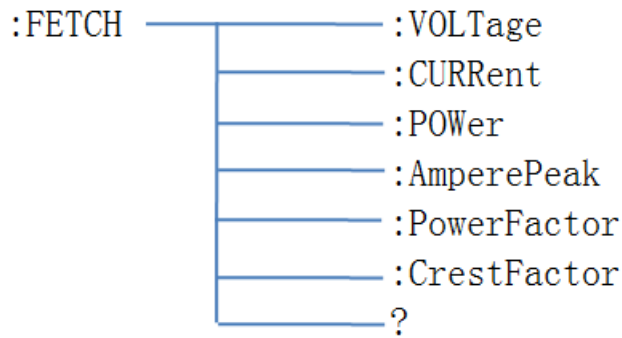

Figure 6-8 FETCH Command Diagram

6.3.6.1 :FETCH: VOLT?

Command Syntax: :FETCH:VOLTage?

Shorthand for command: :FETCH:VOLT?

Command description: This command is used to query the output voltage value in manual mode, and the command is valid when the output is turned on.

6.3.6.2 :FETCH: CURR?

Command Syntax: :FETCH:FETCH:CURRent?

Shorthand for command: :FETCH:CURR?

Command description: This command is used to query the output current value in manual mode, and the command is valid when the output is turned on.

6.3.6.3 :FETCH: POW?

Command Syntax: :FETCH:FETCH:FETCH:POWer?

Shorthand for command: :FETCH:POW?

Command description: This command is used to query the output power value in manual mode, and the command is valid when the output is turned on.

6.3.6.4 :FETCH: AP?

Command Syntax: :FETCH:FETCH:AmperePeak?

Shorthand for command: :FETCH:AP?

Command description: This command is used to query the ampere peak value in manual mode, and the command is valid when the output is turned on.

6.3.6.5 :FETCH: PF?

Command Syntax: :FETCH:PowerFactor?

Shorthand for command: :FETCH:PF?

Command description: This command is used to query the power factor in manual mode, and the command is valid when the output is turned on.

6.3.6.6 :FETCH: CF?

Command Syntax: :FETCH:CrestFactor?

Shorthand for command: :FETCH:CF?

Command description: This command is used to query the crest factor value in manual mode, and the command is valid when the output is turned on.

6.3.6.7 :FETCH?

Command Syntax: :FETCH?

Command description: This command is used to query the measurement parameters such as voltage, current, power, ampere current, power factor, and crest factor in manual mode. The return form is: 100.0, 1.000, 100.0, 1.42, 1.000, 1.413

6.3.7 SYSTem Subsystem Commands

The SYSTem subsystem command is used to set the parameters under the system settings. The SYSTem subsystem command structure is shown in Figure 6-9.

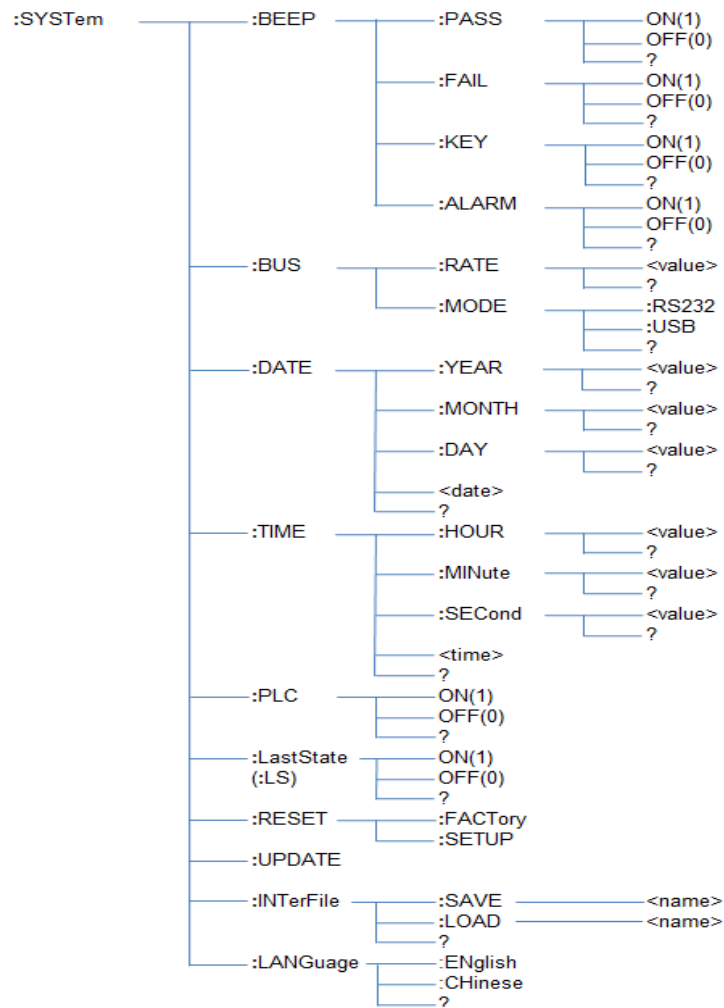

Figure 6-9 SYSTem Commands Structure Diagram

6.3.7.1 :SYST:BEEP

- Command Syntax: :SYSTEM:BEEP:PASS ON or :SYSTEM:BEEP:PASS 1
 Shorthand for command: :SYST:BEEP:PASS ON or :SYST:BEEP:PASS 1
 Command description: This command is used to enable the passing of the test to produce a pass beep.

Command Syntax: :SYSTEM:BEEP:PASS OFF or :SYSTEM:BEEP:PASS 0
 Shorthand for command: :SYST:BEEP:PASS OFF or :SYST:BEEP:PASS 0
 Command description: This command is used to turn off the pass beep.

Command Syntax: :SYSTEM:BEEP:PASS?
 Shorthand for command: :SYST:BEEP:PASS?
 Command description: This command is used to query the status of the PASS beep.

- Command Syntax: :SYSTEM:BEEP:FAIL ON or :SYSTEM:BEEP:FAIL 1
 Shorthand for command: :SYST:BEEP:FAIL ON or :SYST:BEEP:FAIL 1
 Command description: This command is used to enable the failed test to produce a fail beep.

Command Syntax: :SYSTem:BEEP:FAIL OFF or :SYSTem:BEEP:FAIL 0
Shorthand for command: :SYST:BEEP:FAIL OFF or :SYST:BEEP:FAIL 0
Command description: This command is used to turn off the fail beep.

Command Syntax: :SYSTem:BEEP:FAIL?
Shorthand for command: :SYST:BEEP:FAIL?
Command description: This command is used to query the status of the FAIL beep.

- Command Syntax: :SYSTem:BEEP:KEY ON or :SYSTem:BEEP:KEY 1
Shorthand for command: :SYST:BEEP:KEY ON or :SYST:BEEP:KEY 1
Command description: This command is used to turn on the beep key.

Command Syntax: :SYSTem:BEEP:KEY OFF or :SYSTem:BEEP:KEY 0
Shorthand for command: :SYST:BEEP:KEY OFF or :SYST:BEEP:KEY 0
Command description: This command is used to turn off the beep key.

Command Syntax: :SYSTem:BEEP:KEY?
Shorthand for command: :SYST:BEEP:KEY?
Command description: This command is used to query the status of the beep key.

- Command Syntax: :SYSTem:BEEP:ALARM ON or :SYSTem:BEEP:ALARM 1
Shorthand for command: :SYST:BEEP:ALARM ON or :SYST:BEEP:ALARM 1
Command description: This command is used to turn on the alarm beep.

Command Syntax: :SYSTem:BEEP:ALARM OFF or :SYSTem:BEEP:ALARM 0
Shorthand for command: :SYST:BEEP:ALARM OFF or :SYST:BEEP:ALARM 0
Command description: This command is used to turn off the alarm beep.

Command Syntax: :SYSTem:BEEP:ALARM?
Shorthand for command: :SYST:BEEP:ALARM?
Command description: This command is used to query the status of the alarm beep.

6.3.7.2 :SYST:DATE

- Command Syntax: :SYSTem:DATE <date>
Shorthand for command: :SYST:DATE <date>
Command description: This command is used to set the system date. The format of <date> is 2017-8-30.

Command Syntax: :SYSTem:DATE?
Shorthand for command: :SYST:DATE?
Command description: This command is used to query the system date. Returns <date>, which is of the type 2017-8-30.

-
- Command Syntax: :SYSTEM:YEAR<value>
Shorthand for command: :SYST:YEAR <value>
Command description: This command is used to set the system year. <value> can be from 0 to 99 or 2000 to 2099.

Command Syntax: :SYSTEM:YEAR?
Shorthand for command: :SYST:YEAR?
Command description: This command is used to query the year of the system time. Returns <value> with a value equal to 2000~2099.

- Command Syntax: :SYSTEM:MONTH<value>
Shorthand for command: :SYST:MONTH <value>
Command description: This command is used to set the system month. <value> can be from 1 to 12.

Command Syntax: :SYSTEM:MONTH?
Shorthand for command: :SYST:MONTH?
Command description: This command is used to query the month of the system time. Returns <value> is from 1 to 12.

- Command Syntax: :SYSTEM:DATE<value>
Shorthand for command: :SYST:DATE <value>
Command description: This command is used to set the system date. <value> can be from 1 to 31.

Command Syntax: :SYSTEM:DATE?
Shorthand for command: :SYST:DATE?
Command description: This command is used to query the date of the system time. Returns <value> is from 1 to 31.

6.3.7.3 :SYST:TIME

- Command Syntax: :SYSTEM:TIME <time>
Shorthand for command: :SYST:TIME <time>
Command description: This command is used to set the system time. The format of <time> is 08:00:00.

- Command Syntax: :SYSTEM:TIME:HOURL <value>
Shorthand for command: :SYST:TIME:HOURL <value>
Command description: This command is used to set the hour of the system time. <value> ranges from 0 to 23.

Command Syntax: :SYSTEM:TIME:HOURL?
Shorthand for command: :SYST:TIME:HOURL?
Command description: This command is used to query the hour of the system time. Returns <value> , it is 0~23.

-
- Command Syntax: :SYSTem:TIME:MINute <value>
Shorthand for command: :SYST:TIME:MIN <value>
Command description: This command is used to set the minute of the system time. <value> ranges from 0 to 59

Command Syntax: :SYSTem:TIME:MINute?

Shorthand for command: :SYST:TIME:MIN?

Command description: This command is used to query the minute of the system time. Returns <value> , it is 0~59.

- Command Syntax: :SYSTem:TIME:SECond <value>
Shorthand for command: :SYST:TIME:SEC <value>
Command description: This command is used to set the second of the system time. <value> ranges from 0 to 59

Command Syntax: :SYSTem:TIME:SECond?

Shorthand for command: :SYST:TIME:SEC?

Command description: This command is used to query the second of the system time. Returns <value> , it is 0~59.

6.3.7.4 :SYST:PLC

- Command Syntax: :SYSTem:PLC ON or :SYSTem:PLC 1
Shorthand for command: :SYST:PLC ON or :SYST:PLC 1
Command description: This command is used to turn on remote control.

Command Syntax: :SYSTem:PLC OFF or :SYSTem:PLC 0

Shorthand for command: :SYST:PLC OFF or :SYST:PLC 0

Command description: This command is used to turn off remote control.

Command Syntax: :SYSTem:PLC?

Shorthand for command: :SYST:PLC?

Command description: This command is used to query the status of programmable logic control.

6.3.7.5 :SYST:LS

- Command Syntax: :SYSTem>LastState ON or :SYSTem>LastState 1
Shorthand for command: :SYST:LS ON or :SYST:LS 1
Command description: This command is used to keep the last power on state.

Command Syntax: :SYSTem>LastState OFF or :SYSTem>LastState 0

Shorthand for command: :SYST:LS OFF or :SYST:LS 0

Command description: This command is used to not keep the last power on state.

Command Syntax: :SYSTem>LastState?

Shorthand for command: :SYST:LS?

Command description: This command is used to query whether to keep the last boot state.

6.3.7.6 :SYST:RESET

- Command Syntax: :SYSTem:RESET:FACTory

Shorthand for command: :SYST:RESET:FACT

Command description: This command is used to reset the instrument to factory settings.

Command Syntax: :SYSTem:RESET:SETUP

Shorthand for command: :SYST:RESET:SETUP

Command description: This command is used to restore all settings in the measurement settings to their defaults.

6.3.7.7 :SYST:INTF

- Command Syntax: :SYSTem:INTerFile:SAVE <name>

Shorthand for command: :SYST:INTF:SAVE <name>

Command description: This command is used to save files to internal storage.<name> indicates the name of the file to save.When the saved file name has the same name as the internally stored file, the system cannot save it. Users can check whether the file name to be saved and the internally stored file are duplicated by querying the command: SYSTem:INTerFile?.

- Command Syntax: :SYSTem:INTerFile:LOAD <name>

Shorthand for command: :SYST:INTF:LOAD <name>

Command description: This command is used to load internally stored files. <name> indicates the name of the file to load. When the loaded file name is not in the internally stored file, the system will not load. The user can check whether the file name to be loaded is in the internally stored file by querying the command: SYSTem:INTerFile?

Command Syntax: :SYSTem:INTerFile?

Shorthand for command: :SYST:INTF?

Command description: This command is used to query files stored internally.

6.3.7.8 :SYST:LANG

- Command Syntax: :SYSTem:LANGuage ENGLISH

Shorthand for command: :SYST:LANG EN

Command description: This command is used to set the instrument interface to English.

Command Syntax: :SYSTem:LANGuage?

Shorthand for command: :SYST:LANG?

Command description: This command is used to query the language used by the instrument.

6.4 MODBUS Communication Commands

MODBUS is a serial communication protocol published by Modicon for communication using programmable logic controllers (PLCs). MODBUS has become the industry standard for communication protocols in the industrial sector and is now the usual connection between industrial electronic devices.

6.4.1 MODBUS Protocol

6.4.1.1 Description of Writing Instruction

Send Format

0	1	2	3	4	5	6	7	8	9	10	11	12
Instrument address	Function code	High address	Low address	High bytes	Low bytes	Number of data	Data byte 1	Data byte 2	Data byte n	CRC Low	CRC High

Return Format

0	1	2	3	4	5	6	7
Instrument address	Function code	High address	Low address	High bytes	Low bytes	CRC Low	CRC High

1) Sending Address

The sending address refers to the local address of the instrument, which can be set in the parameter bus interface of the communication setting interface of the instrument. The value ranges from 1 to 31.

2) Function Code

The write command function code is: 0x0F.

3) High Address

The address is the storage address of the data in the instrument, and the high address is the high eight bits of the address.

4) Low Address

The address is the storage address of the data in the instrument, and the low address is the low eight bits of the address.

5) High Byte Count

The number of bytes represents the total number of bytes written for this operation. If the data is of type char, the number of bytes is 0x0001; if the data is of type int, the number of bytes is 0x0002; if the data is of type float, the number of bytes is 0x0004.

6) Low Byte Count

The number of bytes represents the total number of bytes written for this operation.

7) Number of Data

The number of data indicates the total number of data written in this operation.

8) Data Byte 1 --Data Byte N

The data byte is to write the set data content to the instrument.

9) CRC High and CRC Low

CRC 16-bit check, using the look-up table method for CRC check.

6.4.1.2 Description of Read Instruction

Send Format

0	1	2	3	4	5	6	7
Instrument address	Function code	High address	Low address	High bytes	Low bytes	CRC Low	CRC High

Return Format

0	1	2	3	4	5	6	7	8	9	10	11
Instrument address	Function code	High address	Low address	High bytes	Low bytes	Data byte 1	Data byte 2	Data byte n	CRC Low	CRC High

1) Sending Address

The sending address refers to the local address of the instrument, which can be set in the parameter bus interface of the communication setting interface of the instrument. The value ranges from 1 to 31.

2) Function Code

The read command function code is: 0x0F.

3) High Address

The address is the storage address of the data in the instrument, and the high address is the high eight bits of the address.

4) Low Address

The address is the storage address of the data in the instrument, and the low address is the low eight bits of

the address.

5) High Byte Count

The number of bytes represents the total number of bytes written for this operation. If the data is of type char, the number of bytes is 0x0001; if the data is of type int, the number of bytes is 0x0002; if the data is of type float, the number of bytes is 0x0004.

6) Low Byte Count

The number of bytes represents the total number of bytes written for this operation.

7) CRC High and CRC Low

CRC 16-bit check, using the look-up table method for CRC check.

6.4.2 MODBUS Write Commands

6.4.2.1 Address 2 (Output Switch)

1) Commands Description

This command is used to control the instrument output. The instruction data byte bit corresponds to the function of the instrument as shown in below table.

Data Byte	Instrument Output Function
0x00	Turn off the AC output and the command is only valid under the measurement display
0x01	Turn on the AC output and the command is only valid under the measurement display

3) Send Instruction Format

Instrument address	Function code	High address	Low address	High bytes	Low bytes	Number of data	Data byte 1	Data byte 2	CRC Low	CRC High
1~32	0x10	0x00	0x02	0x00	0x01	0x02	0x00	0x00or0x01	Calculated based on the first 9 bytes	

4) Return Instruction Format

Instrument address	Function Code	High Address	Low Address	High bytes	Low bytes	CRC Low	CRC High
1~32	0x10	0x00	0x02	0x00	0x01	Calculated based on the first 6 bytes	

Data Byte	Instrument Output Function
0x00	This command is used to set the measure mode to manual mode. The command is invalid when the output is turned on.

0x01	This command is used to set the measure mode to programmable mode. The command is invalid when the output is turned on.
------	---

6.4.2.2 Address 3 (Measurement Mode)

1) Commands Description

This command is used to set the instrument measurement mode. The instruction data byte bit corresponds to the function of the instrument as shown in below tables

2) Send Instruction Format

Instrument address	Function code	High address	Low address	High bytes	Low bytes	Number of data	Data byte 1	Data byte 2	CRC Low	CRC High
1~32	0x10	0x00	0x03	0x00	0x01	0x01	0x00	0x00or 0x01	Calculated based on the first 9 bytes	

3) Return Instruction Format

Instrument address	Function Code	High Address	Low Address	High bytes	Low bytes	CRC Low	CRC High
1~32	0x10	0x00	0x03	0x00	0x01	Calculated based on the first 6 bytes	

6.4.2.3 Address 4 (Memory Sequence)

1) Commands Description

This command is used to set the number of the memory sequence in manual mode. Instruction data byte 1 ranges from 1 to 50. The command is invalid when the output is turned on.

2) Send Instruction Format

Instrument address	Function code	High address	Low address	High bytes	Low bytes	Number of data	Data byte 1	Data byte 2	CRC Low	CRC High
1~32	0x10	0x00	0x04	0x00	0x01	0x01	0x00	0x01~0x32	Calculated based on the first 9 bytes	

3) Return Instruction Format

Instrument address	Function Code	High Address	Low Address	High bytes	Low bytes	CRC Low	CRC High
1~32	0x10	0x00	0x04	0x00	0x01	Calculated based on the first 6 bytes	

6.4.2.4 Address 5 (Set Voltage)

1) Commands Description

This command is used to set the set voltage value in manual mode. The command data range is 0.0~300.0V.

2) Send Instruction Format

Instrument address	Function code	High address	Low address	High bytes	Low bytes	Number of data	Data byte 1~4	CRC Low	CRC High
1~32	0x10	0x00	0x05	0x00	0x02	0x04	0.0~300.0V, 4 bytes stored in float point type	Calculated based on the first 11 bytes	

3) Return Instruction Format

Instrument address	Function Code	High Address	Low Address	High bytes	Low bytes	CRC Low	CRC High
1~32	0x10	0x00	0x05	0x00	0x02	Calculated based on the first 6 bytes	

6.4.2.5 Address 6 (Voltage Mode)

1) Commands Description

This command is used to set the voltage output mode in manual mode. Instruction data byte bit corresponds to instrument voltage output mode as shown in below table.

Data Byte	Instrument voltage output mode function
0x00	This command is used to set the voltage output in manual mode to AUTO mode.
0x01	This command is used to set the voltage output in manual mode to HIGH mode.

2) Send Instruction Format

Instrument address	Function code	High address	Low address	High bytes	Low bytes	Number of data	Data byte 1	Data byte 2	CRC Low	CRC High
1~32	0x10	0x00	0x06	0x00	0x01	0x01	0x00	0x00 or 0x01	Calculated based on the first 9 bytes	

3) Return Instruction Format

Instrument address	Function Code	High Address	Low Address	High bytes	Low bytes	CRC Low	CRC High
1~32	0x10	0x00	0x06	0x00	0x01	Calculated based on the first 6 bytes	

6.4.2.6 Address 7 (Set Frequency)

1) Commands Description

This command is used to set the output frequency value in manual mode. The command data range is 45.0~500Hz. When the frequency is less than 100 Hz, the resolution is 0.1 Hz; when the frequency is not less than 100 Hz, the resolution is 1 Hz.

2) Send Instruction Format

Instrument address	Function code	High address	Low address	High bytes	Low bytes	Number of data	Data byte 1~4	CRC Low	CRC High
1~32	0x10	0x00	0x07	0x00	0x02	0x04	45.5~500.0V, 4 bytes stored in float point type	Calculated based on the first 11 bytes	

3) Return Instruction Format

Instrument address	Function Code	High Address	Low Address	High bytes	Low bytes	CRC Low	CRC High
1~32	0x10	0x00	0x07	0x00	0x02	Calculated based on the first 6 bytes	

6.4.2.7 Address 8 (Current High Limit)

1) Commands Description

This command is used to set the current high limit value in manual mode. When the set voltage is not greater than 150V, the command data range is 0.000~8.400A; when the set voltage is greater than 150V, the command data range is 0.000~4.200A. The command is invalid when the output is turned on.

2) Send Instruction Format

Instrument address	Function code	High address	Low address	High bytes	Low bytes	Number of data	Data byte 1~4	CRC Low	CRC High
1~32	0x10	0x00	0x08	0x00	0x02	0x04	0~8.4 or 0~4.2 , 4 bytes stored in float point type	Calculated based on the first 11 bytes	

3) Return Instruction Format

Instrument address	Function Code	High Address	Low Address	High bytes	Low bytes	CRC Low	CRC High
1~32	0x10	0x00	0x1D	0x00	0x02	Calculated based on the first 6 bytes	

6.4.2.8 Address 9 (Current Low Limit)

1) Commands Description

This command is used to set the current low limit value in manual mode. When the set voltage is not greater than 150V, the command data range is 0.000~8.400A; when the set voltage is greater than 150V, the command data range is 0.000~4.200A. The command is invalid when the output is turned on.

2) Send Instruction Format

Instrument address	Function code	High address	Low address	High bytes	Low bytes	Number of data	Data byte 1~4	CRC Low	CRC High
1~32	0x10	0x00	0x09	0x00	0x02	0x04	0.000~8.400 or 0.000~4.200, 4 bytes stored in float point type	Calculated based on the first 11 bytes	

3) Return Instruction Format

Instrument address	Function Code	High Address	Low Address	High bytes	Low bytes	CRC Low	CRC High
1~32	0x10	0x00	0x09	0x00	0x02	Calculated based on the first 6 bytes	

6.4.2.9 Address 10 (SD Voltage)

1) Commands Description

This command is used to set the voltage value of the surge drop set in manual mode. The instruction data byte range is 0.0~300.0V.

2) Send Instruction Format

Instrument address	Function code	High address	Low address	High bytes	Low bytes	Number of data	Data byte 1~4	CRC Low	CRC High
1~32	0x10	0x00	0x0A	0x00	0x02	0x04	0.0~300.0V, 4 bytes stored in float point type	Calculated based on the first 11 bytes	

3) Return Instruction Format

Instrument address	Function Code	High Address	Low Address	High bytes	Low bytes	CRC Low	CRC High
1~32	0x10	0x00	0x0A	0x00	0x02	Calculated based on the first 6 bytes	

6.4.2.10 Address 11 (SD Position)

1) Commands Description

This command is used to set the position where the surge drop appears in manual mode. Instruction data byte 1 ranges from 0 to 20. The command is invalid when the output is turned on.

2) Send Instruction Format

Instrument address	Function code	High address	Low address	High bytes	Low bytes	Number of data	Data byte 1	Data byte 2	CRC Low	CRC High
1~32	0x10	0x00	0x0B	0x00	0x01	0x02	0x00	0x00~ 0x14	Calculated based on the first 8 bytes	

3) Return Instruction Format

Instrument address	Function Code	High Address	Low Address	High bytes	Low bytes	CRC Low	CRC High
1~32	0x10	0x00	0x0B	0x00	0x01	Calculated based on the first 6 bytes	

6.4.2.11 Address 12 (SD Time)

1) Commands Description

This command is used to set the position where the surge drop appears in manual mode. Instruction data byte 1 ranges from 0 to 20. The command is invalid when the output is turned on.

2) Send Instruction Format

Instrument address	Function code	High address	Low address	High bytes	Low bytes	Number of data	Data byte 1	Data byte 2	CRC Low	CRC High
1~32	0x10	0x00	0x0C	0x00	0x01	0x02	0x00	0x00~ 0x14	Calculated based on the first 9 bytes	

3) Return Instruction Format

Instrument address	Function Code	High Address	Low Address	High bytes	Low bytes	CRC Low	CRC High
1~32	0x10	0x00	0x0C	0x00	0x01	Calculated based on the first 6 bytes	

6.4.2.12 Address 13 (SD Connection)

1) Commands Description

This command is used to control the step connection of the current step. The command is invalid when the output is turned on. The instruction data byte bit corresponds to the function of the instrument as shown below table:

Data Byte	Step Connection
0x00	This command is used to turn off the step connection of the current step.
0x01	This command is used to turn on the step connection of the current step.

2) Send Instruction Format

Instrument address	Function code	High address	Low address	High bytes	Low bytes	Number of data	Data byte 1	Data byte 2	CRC Low	CRC High
1~32	0x10	0x00	0x0D	0x00	0x01	0x02	0x00	0x00 or 0x01	Calculated based on the first 8 bytes	

3) Return Instruction Format

Instrument address	Function Code	High Address	Low Address	High bytes	Low bytes	CRC Low	CRC High
1~32	0x10	0x00	0x0D	0x00	0x01	Calculated based on the first 6 bytes	

6.4.2.13 Address 14 (Voltage High Limit)

1) Commands Description

This command is used to set the voltage upper limit value in manual mode. The command data range is 0.0~300.0V. The command is invalid when the output is turned on.

2) Send Instruction Format

Instrument address	Function code	High address	Low address	High bytes	Low bytes	Number of data	Data byte 1~4	CRC Low	CRC High
1~32	0x10	0x00	0x0E	0x00	0x02	0x04	0.0~300.0V, 4 bytes stored in float point type	Calculated based on the first 11 bytes	

3) Return Instruction Format

Instrument address	Function Code	High Address	Low Address	High bytes	Low bytes	CRC Low	CRC High
1~32	0x10	0x00	0x0E	0x00	0x02	Calculated based on the first 6 bytes	

6.4.2.14 Address 15 (Voltage Low Limit)

1) Commands Description

This command is used to set the voltage lower limit value in manual mode. The command data range is 0.0~300.0V. The command is invalid when the output is turned on.

2) Send Instruction Format

Instrument address	Function code	High address	Low address	High bytes	Low bytes	Number of data	Data byte 1~4	CRC Low	CRC High
1~32	0x10	0x00	0x0F	0x00	0x02	0x04	0.0~300.0V, 4 bytes stored in float point type	Calculated based on the first 11 bytes	

3) Return Instruction Format

Instrument address	Function Code	High Address	Low Address	High bytes	Low bytes	CRC Low	CRC High
1~32	0x10	0x00	0x0F	0x00	0x02	Calculated based on the first 6 bytes	

6.4.2.15 Address 16 (Frequency High Limit)

1) Commands Description

This command is used to set the high limit of the output frequency in manual mode. When the set voltage is not greater than 150V, the command data range is 45.0~500Hz. When the frequency is less than 100 Hz, the resolution is 0.1 Hz; when the frequency is not less than 100 Hz, the resolution is 1 Hz.

2) Send Instruction Format

Instrument address	Function code	High address	Low address	High bytes	Low bytes	Number of data	Data byte 1~4	CRC Low	CRC High
1~32	0x10	0x00	0x10	0x00	0x02	0x04	45.5~500, 4 bytes stored in float point type	Calculated based on the first 11 bytes	

3) Return Instruction Format

Instrument address	Function Code	High Address	Low Address	High bytes	Low bytes	CRC Low	CRC High
1~32	0x10	0x00	0x10	0x00	0x02	Calculated based on the first 6 bytes	

6.4.2.16 Address 17 (Frequency Low Limit)

1) Commands Description

This command is used to set the low limit of the output frequency in manual mode. When the set voltage is not greater than 150V, the command data range is 45.0~500Hz. When the frequency is less than 100 Hz, the resolution is 0.1 Hz; when the frequency is not less than 100 Hz, the resolution is 1 Hz.

2) Send Instruction Format

Instrument address	Function code	High address	Low address	High bytes	Low bytes	Number of data	Data byte 1~4	CRC Low	CRC High
1~32	0x10	0x00	0x11	0x00	0x02	0x04	45.5~500, 4 bytes stored in float point type	Calculated based on the first 11 bytes	

3) Return Instruction Format

Instrument address	Function Code	High Address	Low Address	High bytes	Low bytes	CRC Low	CRC High
1~32	0x10	0x00	0x11	0x00	0x02	Calculated based on the first 6 bytes	

6.4.2.17 Address 18 (Start Angle)

1) Commands Description

This command is used to set the low limit of the output frequency in manual mode. When the set voltage is not greater than 150V, the command data range is 45.0~500Hz. When the frequency is less than 100 Hz, the resolution is 0.1 Hz; when the frequency is not less than 100 Hz, the resolution is 1 Hz.

This command is used to set the starting angle in manual mode. The command data range is 0~359. The command is invalid when the output is turned on.

2) Send Instruction Format

Instrument address	Function code	High address	Low address	High bytes	Low bytes	Number of data	Data byte 1	Data byte 2	CRC Low	CRC High
1~32	0x10	0x00	0x12	0x00	0x01	0x02	0~359 High 8-bit	0~359 low 8-bit	Calculated based on the first 9 bytes	

3) Return Instruction Format

Instrument address	Function Code	High Address	Low Address	High bytes	Low bytes	CRC Low	CRC High
1~32	0x10	0x00	0x12	0x00	0x01	Calculated based on the first 6 bytes	

6.4.2.18 Address 19 (End Angle)

1) Commands Description

This command is used to set the end angle in manual mode. The command data range is 0~359. The command is invalid when the output is turned on.

2) Send Instruction Format

Instrument address	Function code	High address	Low address	High bytes	Low bytes	Number of data	Data byte 1	Data byte 2	CRC Low	CRC High
1~32	0x10	0x00	0x13	0x00	0x01	0x02	0~359 High 8-bit	0~359 low 8-bit	Calculated based on the first 9 bytes	

3) Return Instruction Format

Instrument address	Function Code	High Address	Low Address	High bytes	Low bytes	CRC Low	CRC High
1~32	0x10	0x00	0x13	0x00	0x01	Calculated based on the first 6 bytes	

6.4.2.19 Address 20 (Measurement Result)

1) Commands Description

This command is used to set the result display mode in manual mode. The command is invalid when the output is turned on. The instruction data byte bit corresponds to the function of the instrument as shown in below table:

Data Byte	Result Display Mode
0x00	This command is used to set the result display mode to NONE in manual mode.
0x01	This command is used to set the result display mode to LAST in manual mode.
0x02	This command is used to set the result display mode to ALL in manual mode.
0x03	This command is used to set the result display mode to P/F in manual mode.

2) Send Instruction Format

Instrument address	Function code	High address	Low address	High bytes	Low bytes	Number of data	Data byte 1	Data byte 2	CRC Low	CRC High
1~32	0x10	0x00	0x14	0x00	0x01	0x02	0x00	0x00 or 0x01 or 0x02 or 0x03	Calculated based on the first 9 bytes	

3) Return Instruction Format

Instrument address	Function Code	High Address	Low Address	High bytes	Low bytes	CRC Low	CRC High

1~32	0x10	0x00	0x14	0x00	0x01	Calculated based on the first 6 bytes
------	------	------	------	------	------	---------------------------------------

6.4.2.20 Address 21 (Surge Drop)

1) Commands Description

This command is used to control the glitch trap in manual mode. The command is invalid when the output is turned on. The instruction data byte bit corresponds to the function of the instrument as shown in below table:

Data Byte	Step Connection
0x00	This command is used to turn off the surge drop in manual mode.
0x01	This command is used to turn on the surge drop in manual mode.

2) Send Instruction Format

Instrument address	Function code	High address	Low address	High bytes	Low bytes	Number of data	Data byte 1	Data byte 2	CRC Low	CRC High
1~32	0x10	0x00	0x15	0x00	0x01	0x02	0x00	0x00 or 0x01	Calculated based on the first 9 bytes	

3) Return Instruction Format

Instrument address	Function Code	High Address	Low Address	High bytes	Low bytes	CRC Low	CRC High
1~32	0x10	0x00	0x15	0x00	0x01	Calculated based on the first 6 bytes	

6.4.2.21 Address 22 (Over Current Fold)

1) Commands Description

This command is used to control the over current fold function in manual mode. The command is invalid when the output is turned on. The instruction data byte bit corresponds to the function of the instrument as shown in below table:

Data Byte	Over Current Fold Function
0x00	This command is used to turn off the overcurrent fold function in manual mode.
0x01	This command is used to turn on the overcurrent fold function in manual mode.

2) Send Instruction Format

Instrument address	Function code	High address	Low address	High bytes	Low bytes	Number of data	Data byte 1	Data byte 2	CRC Low	CRC High
1~32	0x10	0x00	0x15	0x00	0x01	0x02	0x00	0x00 or 0x01	Calculated based on the first 9 bytes	

1~32	0x10	0x00	0x16	0x00	0x01	0x02	0x00	0x00 or 0x01	Calculated based on the first 8 bytes
------	------	------	------	------	------	------	------	--------------------	---------------------------------------

3) Return Instruction Format

Instrument address	Function Code	High Address	Low Address	High bytes	Low bytes	CRC Low	CRC High
1~32	0x10	0x00	0x16	0x00	0x01	Calculated based on the first 6 bytes	

6.4.2.22 Address 23 (Voltage Limit)

1) Commands Description

This command is used to set the allowable difference between the output voltage and the set voltage in manual mode. The command data range is 5.0~50.0V.

2) Send Instruction Format

Instrument address	Function code	High address	Low address	High bytes	Low bytes	Number of data	Data byte 1~4	CRC Low	CRC High
1~32	0x10	0x00	0x17	0x00	0x02	0x04	5.0~50.0, 4 bytes stored in float point type	Calculated based on the first 11 bytes	

3) Return Instruction Format

Instrument address	Function Code	High Address	Low Address	High bytes	Low bytes	CRC Low	CRC High
1~32	0x10	0x00	0x17	0x00	0x02	Calculated based on the first 6 bytes	

6.4.2.23 Address 24 (Timer Seconds)

1) Commands Description

This command is used to set the value of the timer seconds in manual mode. Instruction data byte 1 ranges from 0 to 59. The command is invalid when the output is turned on.

2) Send Instruction Format

Instrument address	Function code	High address	Low address	High bytes	Low bytes	Number of data	Data byte 1	Data byte 2	CRC Low	CRC High

1~32	0x10	0x00	0x18	0x00	0x01	0x02	0x00	0x00~0x3B	Calculated based on the first 9 bytes
------	------	------	------	------	------	------	------	-----------	---------------------------------------

3) Return Instruction Format

Instrument address	Function Code	High Address	Low Address	High bytes	Low bytes	CRC Low	CRC High
1~32	0x10	0x00	0x18	0x00	0x01	Calculated based on the first 6 bytes	

6.4.2.24 Address 25 (Timer Minutes)

1) Commands Description

This command is used to set the value of the timer minutes in manual mode. Instruction data byte 1 ranges from 0 to 59. The command is invalid when the output is turned on.

2) Send Instruction Format

Instrument address	Function code	High address	Low address	High bytes	Low bytes	Number of data	Data byte 1	Data byte 2	CRC Low	CRC High
1~32	0x10	0x00	0x19	0x00	0x01	0x02	0x00	0x00~0x3B	Calculated based on the first 9 bytes	

3) Return Instruction Format

Instrument address	Function Code	High Address	Low Address	High bytes	Low bytes	CRC Low	CRC High
1~32	0x10	0x00	0x19	0x00	0x01	Calculated based on the first 6 bytes	

6.4.2.25 Address 26 (Timer Hours)

1) Commands Description

This command is used to set the value of the timer hours in manual mode. Instruction data byte 1 ranges from 0 to 99. The command is invalid when the output is turned on.

2) Send Instruction Format

Instrument address	Function code	High address	Low address	High bytes	Low bytes	Number of data	Data byte 1	Data byte 2	CRC Low	CRC High
1~32	0x10	0x00	0x19	0x00	0x01	0x02	0x00	0x00~0x3B	Calculated based on the first 9 bytes	

1~32	0x10	0x00	0x1A	0x00	0x01	0x01	0x00	0x00~0x63	Calculated based on the first 9 bytes
------	------	------	------	------	------	------	------	-----------	---------------------------------------

3) Return Instruction Format

Instrument address	Function Code	High Address	Low Address	High bytes	Low bytes	CRC Low	CRC High
1~32	0x10	0x00	0x1A	0x00	0x01	Calculated based on the first 6 bytes	

6.4.2.26 Address 27 (Memory Sequence)

1) Commands Description

This command is used to set the number of the memory sequence in the programmable mode. Instruction data byte 1 ranges from 1 to 50. The command is invalid when the output is turned on.

2) Send Instruction Format

Instrument address	Function code	High address	Low address	High bytes	Low bytes	Number of data	Data byte 1	Data byte 2	CRC Low	CRC High
1~32	0x10	0x00	0x1B	0x00	0x01	0x01	0x00	0x01~0x32	Calculated based on the first 8 bytes	

3) Return Instruction Format

Instrument address	Function Code	High Address	Low Address	High bytes	Low bytes	CRC Low	CRC High
1~32	0x10	0x00	0x1B	0x00	0x01	Calculated based on the first 6 bytes	

6.4.2.27 Address 28 (Sequence Number)

1) Command Description

This command is used to set the number of cycles of the current memory sequence in the programmed mode. Instruction data range is 0~999. Command is invalid when output is turned on.

2) Send Instruction Format

Instrument address	Function code	High address	Low address	High bytes	Low bytes	Number of data	Data byte 1	Data byte 2	CRC Low	CRC High
1~32	0x10	0x00	0x1B	0x00	0x01	0x01	0x00	0x01~0x32	Calculated based on the first 8 bytes	

1~32	0x10	0x00	0x1C	0x00	0x01	0x02	0~999 High 8-bit	0~999 Low 8-bit	Calculated based on the first 9 bytes
------	------	------	------	------	------	------	------------------------	-----------------------	---

3) Return Instruction Format

Instrument address	Function Code	High Address	Low Address	High bytes	Low bytes	CRC Low	CRC High
1~32	0x10	0x00	0x1C	0x00	0x01	Calculated based on the first 6 bytes	

6.4.2.28 Address 29 (Step)

1) Command Description

This command is used to set the number of the steps in the programmed mode. Instruction data byte 1 range is 1~9. Command is invalid when output is turned on.

2) Send Instruction Format

Instrument address	Function code	High address	Low address	High bytes	Low bytes	Number of data	Data byte 1	Data byte 2	CRC Low	CRC High
1~32	0x10	0x00	0x1D	0x00	0x01	0x02	0x00	0x01~0x09	Calculated based on the first 9 bytes	

3) Return Instruction Format

Instrument address	Function Code	High Address	Low Address	High bytes	Low bytes	CRC Low	CRC High
1~32	0x10	0x00	0x1D	0x00	0x02	Calculated based on the first 6 bytes	

6.4.2.29 Address 30 (Step Number)

1) Command Description

This command is used to set the number of cycles for the current step in the programmed mode. The command data range is from 0 to 999. Command is invalid when output is turned on.

2) Send Instruction Format

Instrument address	Function code	High address	Low address	High bytes	Low bytes	Number of data	Data byte 1	Data byte 2	CRC Low	CRC High
--------------------	---------------	--------------	-------------	------------	-----------	----------------	-------------	-------------	---------	----------

1~32	0x10	0x00	0x1E	0x00	0x01	0x02	0~999 High 8-bit	0~999 Low 8-bit	Calculated based on the first 9 bytes
------	------	------	------	------	------	------	------------------------	-----------------------	---

3) Return Instruction Format

Instrument address	Function Code	High Address	Low Address	High bytes	Low bytes	CRC Low	CRC High
1~32	0x10	0x00	0x1E	0x00	0x01	Calculated based on the first 6 bytes	

6.4.2.30 Address 31 (Setting Voltage)

1) Command Description

This command is used to set the set voltage value in the programmed mode. The command data range is 0.0~300.0V.

2) Send Instruction Format

Instrument address	Function code	High address	Low address	High bytes	Low bytes	Number of data	Data byte 1~4	CRC Low	CRC High
1~32	0x10	0x00	0x1F	0x00	0x02	0x04	0.0~300.0V, 4 bytes stored in float point type	Calculated based on the first 11 bytes	

3) Return Instruction Format

Instrument address	Function Code	High Address	Low Address	High bytes	Low bytes	CRC Low	CRC High
1~32	0x10	0x00	0x1F	0x00	0x02	Calculated based on the first 6 bytes	

6.4.2.31 Address 32 (Voltage Mode)

1) Command Description

This command is used to set the voltage output mode in manual mode. Instruction data byte bit corresponds to instrument voltage output mode as shown in below table:

Data Byte	Instrument voltage output mode function
0x00	This command is used to set the voltage output in manual mode to AUTO mode.
0x01	This command is used to set the voltage output in manual mode to HIGH mode.

2) Send Instruction Format

Instrument address	Function code	High address	Low address	High bytes	Low bytes	Number of data	Data byte 1	Data byte 2	CRC Low	CRC High
1~32	0x10	0x00	0x20	0x00	0x01	0x02	0x00	0x00 or 0x01	Calculated based on the first 8 bytes	

3) Return Instruction Format

Instrument address	Function Code	High Address	Low Address	High bytes	Low bytes	CRC Low	CRC High
1~32	0x10	0x00	0x20	0x00	0x01	Calculated based on the first 6 bytes	

6.4.2.32 Address 33 (Current High Limit)

1) Command Description

This command is used to set the current high limit of the current step in the programmed mode. When the set voltage is not greater than 150V, the command data range is 0.000~8.400A; when the set voltage is greater than 150V, the command data range is 0.000~4.200A. Command is invalid when output is turned on.

2) Send Instruction Format

Instrument address	Function code	High address	Low address	High bytes	Low bytes	Number of data	Data byte 1~4	CRC Low	CRC High
1~32	0x10	0x00	0x21	0x00	0x02	0x04	0.000~8.400 or 0.000~4.200, 4 bytes stored in float point type	Calculated based on the first 11 bytes	

3) Return Instruction Format

Instrument address	Function Code	High Address	Low Address	High bytes	Low bytes	CRC Low	CRC High
1~32	0x10	0x00	0x21	0x00	0x02	Calculated based on the first 6 bytes	

6.4.2.33 Address 34 (Command Low Limit)

1) Command Description

This command is used to set the current low limit value of the current step in the programmed mode. When the set voltage is not greater than 150V, the command data range is 0.000~8.400A; when the set voltage is greater than 150V, the command data range is 0.000~4.200A. Command is invalid when output

is turned on.

2) Send Instruction Format

Instrument address	Function code	High address	Low address	High bytes	Low bytes	Number of data	Data byte 1~4	CRC Low	CRC High
1~32	0x10	0x00	0x22	0x00	0x02	0x04	0.000~8.400 or 0.000~4.200, 4 bytes stored in float point type	Calculated based on the first 11 bytes	

3) Return Instruction Format

Instrument address	Function Code	High Address	Low Address	High bytes	Low bytes	CRC Low	CRC High
1~32	0x10	0x00	0x22	0x00	0x02	Calculated based on the first 6 bytes	

6.4.2.34 Address 35 (Setting Frequency)

1) Command Description

This command is used to set the output frequency value of the current step in the programmed mode. The command data range is 45.0~500Hz. When the frequency is less than 100 Hz, the resolution is 0.1 Hz; when the frequency is not less than 100 Hz, the resolution is 1 Hz. Command is invalid when output is turned on.

2) Send Instruction Format

Instrument address	Function code	High address	Low address	High bytes	Low bytes	Number of data	Data byte 1~4	CRC Low	CRC High
1~32	0x10	0x00	0x23	0x00	0x02	0x04	45.5~50, 4 bytes stored in float point type	Calculated based on the first 11 bytes	

3) Return Instruction Format

Instrument address	Function Code	High Address	Low Address	High bytes	Low bytes	CRC Low	CRC High
1~32	0x10	0x00	0x23	0x00	0x02	Calculated based on the first 6 bytes	

6.4.2.35 Address 36 (Step Connection)

1) Command Description

This command is used to open the step connection of the current step. Command is invalid when output

is turned on. The instruction data byte bit corresponds to the step of the current step of the instrument as shown in below table:

Data Byte	Step Connection Status
0x00	This command is used to turn on the step connection of the current step. Command is invalid when output is turned on.
0x01	This command is used to turn off the step connection of the current step. Command is invalid when output is turned on.

2) Send Instruction Format

Instrument address	Function code	High address	Low address	High bytes	Low bytes	Number of data	Data byte 1	Data byte 2	CRC Low	CRC High
1~32	0x10	0x00	0x24	0x00	0x01	0x02	0x00	0x00 or 0x01	Calculated based on the first 8 bytes	

3) Return Instruction Format

Instrument address	Function Code	High Address	Low Address	High bytes	Low bytes	CRC Low	CRC High
1~32	0x10	0x00	0x24	0x00	0x01	Calculated based on the first 6 bytes	

6.4.2.36 Address 37(AP High Limit)

1) Command Description

This command is used to set the peak current high limit value of the current step in the programmed mode. When the voltage mode is "AUTO" and the voltage is less than 150V, the range is 0.0~33.6A; when the voltage mode is "AUTO" and the voltage is greater than 150V or the voltage mode is "HIGH", the range is 0.0~16.8A. When this parameter is set to 0.0, this function is turned off. Command is invalid when output is turned on.

2) Send Instruction Format

Instrument address	Function code	High address	Low address	High bytes	Low bytes	Number of data	Data byte 1~4	CRC Low	CRC High
1~32	0x10	0x00	0x25	0x00	0x02	0x04	0.0~16.8 or 0.0~33.6, 4 bytes stored in float point type	Calculated based on the first 11 bytes	

3) Return Instruction Format

Instrument address	Function Code	High Address	Low Address	High bytes	Low bytes	CRC Low	CRC High

1~32	0x10	0x00	0x25	0x00	0x02	Calculated based on the first 6 bytes
------	------	------	------	------	------	---------------------------------------

6.4.2.37 Address 38 (AP Low Limit)

1) Command Description

This command is used to set the peak current low limit value of the current step in the programmed mode. When the voltage mode is "AUTO" and the voltage is less than 150V, the range is 0.0~33.6A; when the voltage mode is "AUTO" and the voltage is greater than 150V or the voltage mode is "HIGH", the range is 0.0~16.8A. When this parameter is set to 0.0, this function is turned off. Command is invalid when output is turned on.

2) Send Instruction Format

Instrument address	Function code	High address	Low address	High bytes	Low bytes	Number of data	Data byte 1~4	CRC Low	CRC High
1~32	0x10	0x00	0x26	0x00	0x02	0x04	0.0~16.8 or 0.0~33.6, 4 bytes stored in float point type	Calculated based on the first 11 bytes	

3) Return Instruction Format

Instrument address	Function Code	High Address	Low Address	High bytes	Low bytes	CRC Low	CRC High
1~32	0x10	0x00	0x26	0x00	0x02	Calculated based on the first 6 bytes	

6.4.2.38 Address 39 (Power High Limit)

1) Command Description

This command is used to set the power high limit of the current step in the programmed mode. The command data range is from 0.0 to 1000W. Command is invalid when output is turned on.

2) Send Instruction Format

Instrument address	Function code	High address	Low address	High bytes	Low bytes	Number of data	Data byte 1~4	CRC Low	CRC High
1~32	0x10	0x00	0x27	0x00	0x02	0x04	0.0~1000, 4 bytes stored in float point type	Calculated based on the first 11 bytes	

3) Return Instruction Format

Instrument address	Function Code	High Address	Low Address	High bytes	Low bytes	CRC Low	CRC High
1~32	0x10	0x00	0x27	0x00	0x02	Calculated based on the first 6 bytes	

6.4.2.39 Address 40 (Power Low Limit)

1) Command Description

This command is used to set the power low limit of the current step in the programmed mode. The command data range is from 0.0 to 1000W. Command is invalid when output is turned on.

2) Send Instruction Format

Instrument address	Function code	High address	Low address	High bytes	Low bytes	Number of data	Data byte 1~4	CRC Low	CRC High
1~32	0x10	0x00	0x28	0x00	0x02	0x04	0.0~1000, 4 bytes stored in float point type	Calculated based on the first 11 bytes	

3) Return Instruction Format

Instrument address	Function Code	High Address	Low Address	High bytes	Low bytes	CRC Low	CRC High
1~32	0x10	0x00	0x28	0x00	0x02	Calculated based on the first 6 bytes	

6.4.2.40 Address 41 (PF High Limit)

1) Command Description

This command is used to set the high limit of the power factor of the current step in the programmed mode. The command data range is 0.000~1.000. Command is invalid when output is turned on.

2) Send Instruction Format

Instrument address	Function code	High address	Low address	High bytes	Low bytes	Number of data	Data byte 1~4	CRC Low	CRC High
1~32	0x10	0x00	0x29	0x00	0x02	0x04	0.0~1000, 4 bytes stored in float point type	Calculated based on the first 11 bytes	

3) Return Instruction Format

Instrument address	Function Code	High Address	Low Address	High bytes	Low bytes	CRC Low	CRC High
1~32	0x10	0x00	0x29	0x00	0x02	Calculated based on the first 6 bytes	

1~32	0x10	0x00	0x29	0x00	0x02	Calculated based on the first 6 bytes
------	------	------	------	------	------	---------------------------------------

6.4.2.41 Address 42 (PF Low Limit)

1) Command Description

This command is used to set the power factor low limit value of the current step in the programmed mode. Instruction data range is 0.000~1.000. Command is invalid when output is turned on.

2) Send Instruction Format

Instrument address	Function code	High address	Low address	High bytes	Low bytes	Number of data	Data byte 1~4	CRC Low	CRC High
1~32	0x10	0x00	0x2A	0x00	0x02	0x04	0.0~1000, 4 bytes stored in float point type	Calculated based on the first 11 bytes	

3) Return Instruction Format

Instrument address	Function Code	High Address	Low Address	High bytes	Low bytes	CRC Low	CRC High
1~32	0x10	0x00	0x2A	0x00	0x02	Calculated based on the first 6 bytes	

6.4.2.42 Address 43 (Time Unit)

1) Command Description

This command is used to set the unit of delay determination time and test time in the programmed mode. Command is invalid when output is turned on. The instruction data byte bit corresponds to the function of the instrument as shown below:

Data Byte	Result Display Mode
0x00	This command is used to set the delay judgment time and test time in the programmed mode as seconds.
0x01	This command is used to set the delay judgment time and test time in the programmed mode as minutes.
0x02	This command is used to set the delay judgment time and test time in the programmed mode as hours.

2) Send Instruction Format

Instrument address	Function code	High address	Low address	High bytes	Low bytes	Number of data	Data byte 1	Data byte 2	CRC Low	CRC High

1~32	0x10	0x00	0x2B	0x00	0x01	0x02	0x00	0x00 or 0x01 or 0x02	Calculated based on the first 8 bytes
------	------	------	------	------	------	------	------	----------------------------	--

3) Return Instruction Format

Instrument address	Function Code	High Address	Low Address	High bytes	Low bytes	CRC Low	CRC High
1~32	0x10	0x00	0x2B	0x00	0x01	Calculated based on the first 6 bytes	

6.4.2.43 Address 44 (Delay Time)

1) Command Description

This command is used to set the delay determination time of the current step in the programmed mode. When the unit is second, the range is 0.1~999.9s; when the unit is minute, the range is 0.1~999.9m; when the unit is time, the range is 0.1~999.9h. Command is invalid when output is turned on.

2) Send Instruction Format

Instrument address	Function code	High address	Low address	High bytes	Low bytes	Number of data	Data byte 1~4	CRC Low	CRC High
1~32	0x10	0x00	0x2C	0x00	0x02	0x04	0.1~999.9, 4 bytes stored in float point type	Calculated based on the first 11 bytes	

3) Return Instruction Format

Instrument address	Function Code	High Address	Low Address	High bytes	Low bytes	CRC Low	CRC High
1~32	0x10	0x00	0x2C	0x00	0x04	Calculated based on the first 6 bytes	

6.4.2.44 Address 45 (Test Time)

1) Command Description

This command is used to set the test time of the current step in the programmed mode. When the unit is second, the range is 0.1~999.9s; when the unit is minute, the range is 0.1~999.9m; when the unit is time, the range is 0.1~999.9h. Command is invalid when output is turned on.

2) Send Instruction Format

Instrument address	Function code	High address	Low address	High bytes	Low bytes	Number of data	Data byte 1~4	CRC Low	CRC High
1~32	0x10	0x00	0x2C	0x00	0x02	0x04	0.1~999.9, 4 bytes stored in float point type	Calculated based on the first 11 bytes	

1~32	0x10	0x00	0x2D	0x00	0x02	0x04	0.1~999.9, 4 bytes stored in float point type	Calculated based on the first 11 bytes	
------	------	------	------	------	------	------	---	---	--

3) Return Instruction Format

Instrument address	Function Code	High Address	Low Address	High bytes	Low bytes	CRC Low	CRC High
1~32	0x10	0x00	0x2D	0x00	0x02	Calculated based on the first 6 bytes	

6.4.2.45 Address 46 (Rise Time)

1) Command Description

This command is used to set the rise time of the current step in the programmed mode. The command data range is from 0.0 to 999.9s. Command is invalid when output is turned on.

2) Send Instruction Format

Instrument address	Function code	High address	Low address	High bytes	Low bytes	Number of data	Data byte 1~4	CRC Low	CRC High
1~32	0x10	0x00	0x2E	0x00	0x02	0x02	0.0~999.9, 4 bytes stored in float point type	Calculated based on the first 11 bytes	

3) Return Instruction Format

Instrument address	Function Code	High Address	Low Address	High bytes	Low bytes	CRC Low	CRC High
1~32	0x10	0x00	0x2E	0x00	0x02	Calculated based on the first 6 bytes	

6.4.2.46 Address 47 (Fall Time)

1) Command Description

This command is used to set the fall time of the current step in the programmed mode. The command data range is from 0.0 to 999.9s. Command is invalid when output is turned on.

2) Send Instruction Format

Instrument address	Function code	High address	Low address	High bytes	Low bytes	Number of data	Data byte 1~4	CRC Low	CRC High
1~32	0x10	0x00	0x2E	0x00	0x02	0x02	0.0~999.9, 4 bytes stored in float point type	Calculated based on the first 11 bytes	

1~32	0x10	0x00	0x2F	0x00	0x02	0x02	0.0~999.9, 4 bytes stored in float point type	Calculated based on the first 11 bytes	
------	------	------	------	------	------	------	---	--	--

3) Return Instruction Format

Instrument address	Function Code	High Address	Low Address	High bytes	Low bytes	CRC Low	CRC High
1~32	0x10	0x00	0x2F	0x00	0x02	Calculated based on the first 6 bytes	

6.4.2.47 Address 48 (SD Voltage)

1) Command Description

This command is used to set the voltage value of the surge drop in the programmed mode. The command data range is 0.0~300.0V. Command is invalid when output is turned on.

2) Send Instruction Format

Instrument address	Function code	High address	Low address	High bytes	Low bytes	Number of data	Data byte 1~4	CRC Low	CRC High
1~32	0x10	0x00	0x30	0x00	0x02	0x04	0.0~300.0V, 4 bytes stored in float point type	Calculated based on the first 11 bytes	

3) Return Instruction Format

Instrument address	Function Code	High Address	Low Address	High bytes	Low bytes	CRC Low	CRC High
1~32	0x10	0x00	0x30	0x00	0x02	Calculated based on the first 6 bytes	

6.4.2.48 Address 49 (SD Position)

1) Command Description

This command is used to set the position where the surge drop appears in the programmed mode. The command data range is 0~20. Command is invalid when output is turned on.

2) Send Instruction Format

Instrument address	Function code	High address	Low address	High bytes	Low bytes	Number of data	Data byte 1	Data byte 2	CRC Low	CRC High
1~32	0x10	0x00	0x31	0x00	0x01	0x02	0x00	0x00~0x14	Calculated based on the first 8 bytes	

3) Return Instruction Format

Instrument address	Function Code	High Address	Low Address	High bytes	Low bytes	CRC Low	CRC High
1~32	0x10	0x00	0x31	0x00	0x01	Calculated based on the first 6 bytes	

6.4.2.49 Address 50 (SD Time)

1) Command Description

This command is used to set the time width of the surge drop in the programmed mode. The command data range is 0~20. Command is invalid when output is turned on.

2) Send Instruction Format

Instrument address	Function code	High address	Low address	High bytes	Low bytes	Number of data	Data byte 1	Data byte 2	CRC Low	CRC High
1~32	0x10	0x00	0x32	0x00	0x01	0x01	0x00	0x00~0x14	Calculated based on the first 8 bytes	

3) Return Instruction Format

Instrument address	Function Code	High Address	Low Address	High bytes	Low bytes	CRC Low	CRC High
1~32	0x10	0x00	0x32	0x00	0x01	Calculated based on the first 6 bytes	

6.4.2.50 Address 51 (SD Connection)

1) Command Description

This command is used to control the step connection of the current step in the programmed mode. Command is invalid when output is turned on. The instruction data byte bit corresponds to the function of the instrument as shown below:

Data Byte	Step Connection
0x00	This command is used to turn off the step connection of the current step.
0x01	This command is used to turn on the step connection of the current step.

2) Send Instruction Format

Instrument address	Function code	High address	Low address	High bytes	Low bytes	Number of data	Data byte 1	Data byte 2	CRC Low	CRC High
1~32	0x10	0x00	0x32	0x00	0x01	0x01	0x00	0x00~0x14	Calculated based on the first 8 bytes	

1~32	0x10	0x00	0x33	0x00	0x01	0x01	0x00	0x00 or 0x01	Calculated based on the first 8 bytes
------	------	------	------	------	------	------	------	--------------------	---------------------------------------

3) Return Instruction Format

Instrument address	Function Code	High Address	Low Address	High bytes	Low bytes	CRC Low	CRC High
1~32	0x10	0x00	0x33	0x00	0x01	Calculated based on the first 6 bytes	

6.4.2.51 Address 52 (Voltage High Limit)

1) Command Description

This command is used to set the high voltage limit value in the programmed mode. The command data range is 0.0~300.0V. Command is invalid when output is turned on.

2) Send Instruction Format

Instrument address	Function code	High address	Low address	High bytes	Low bytes	Number of data	Data byte 1~4	CRC Low	CRC High
1~32	0x10	0x00	0x34	0x00	0x02	0x04	0.0~300.0V, 4 bytes stored in float point type	Calculated based on the first 11 bytes	

3) Return Instruction Format

Instrument address	Function Code	High Address	Low Address	High bytes	Low bytes	CRC Low	CRC High
1~32	0x10	0x00	0x34	0x00	0x02	Calculated based on the first 6 bytes	

6.4.2.52 Address 53 (Voltage Low Limit)

1) Command Description

This command is used to set the low voltage limit value in the programmed mode. The command data range is 0.0~300.0V. Command is invalid when output is turned on.

2) Send Instruction Format

Instrument address	Function code	High address	Low address	High bytes	Low bytes	Number of data	Data byte 1~4	CRC Low	CRC High
1~32	0x10	0x00	0x34	0x00	0x02	0x04	0.0~300.0V, 4 bytes stored in float point type	Calculated based on the first 11 bytes	

1~32	0x10	0x00	0x35	0x00	0x02	0x04	0.0~300.0V, 4 bytes stored in float point type	Calculated based on the first 11 bytes
------	------	------	------	------	------	------	--	--

3) Return Instruction Format

Instrument address	Function Code	High Address	Low Address	High bytes	Low bytes	CRC Low	CRC High
1~32	0x10	0x00	0x35	0x00	0x02	Calculated based on the first 6 bytes	

6.4.2.53 Address 54 (Frequency High Limit)

1) Command Description

This command is used to set the high limit of the output frequency of the current step in the programmed mode. When the set voltage is not greater than 150V, the command data range is 45.0~500Hz. When the frequency is less than 100 Hz, the resolution is 0.1 Hz; when the frequency is not less than 100 Hz, the resolution is 1 Hz.

2) Send Instruction Format

Instrument address	Function code	High address	Low address	High bytes	Low bytes	Number of data	Data byte 1~4	CRC Low	CRC High
1~32	0x10	0x00	0x36	0x00	0x02	0x04	45.0~500.0V, 4 bytes stored in float point type	Calculated based on the first 11 bytes	

3) Return Instruction Format

Instrument address	Function Code	High Address	Low Address	High bytes	Low bytes	CRC Low	CRC High
1~32	0x10	0x00	0x36	0x00	0x02	Calculated based on the first 6 bytes	

6.4.2.54 Address 55 (Frequency Low Limit)

1) Command Description

This command is used to set the low limit of the output frequency of the current step in the programmed mode. When the set voltage is not greater than 150V, the command data range is 45.0~500Hz. When the frequency is less than 100 Hz, the resolution is 0.1 Hz; when the frequency is not less than 100 Hz, the resolution is 1 Hz.

2) Send Instruction Format

Instrument address	Function code	High address	Low address	High bytes	Low bytes	Number of data	Data byte 1~4	CRC Low	CRC High
1~32	0x10	0x00	0x37	0x00	0x02	0x04	45.0~500.0V, 4 bytes stored in float point type	Calculated based on the first 11 bytes	

3) Return Instruction Format

Instrument address	Function Code	High Address	Low Address	High bytes	Low bytes	CRC Low	CRC High
1~32	0x10	0x00	0x37	0x00	0x02	Calculated based on the first 6 bytes	

6.4.2.55 Address 56 (Starting Angle)

1) Command Description

This command is used to set the starting angle in the programmed mode. Instruction data range is 0~359. Command is invalid when output is turned on.

2) Send Instruction Format

Instrument address	Function code	High address	Low address	High bytes	Low bytes	Number of data	Data byte 1	Data byte 2	CRC Low	CRC High
1~32	0x10	0x00	0x38	0x00	0x01	0x02	0~359 High 8-bit	0~359 Low 8-bit	Calculated based on the first 9 bytes	

3) Return Instruction Format

Instrument address	Function Code	High Address	Low Address	High bytes	Low bytes	CRC Low	CRC High
1~32	0x10	0x00	0x38	0x00	0x01	Calculated based on the first 6 bytes	

6.4.2.56 Address 57 (End Angle)

1) Command Description

This command is used to set the end angle in the programmed mode. Instruction data range is 0~359. Command is invalid when output is turned on.

2) Send Instruction Format

Instrument address	Function code	High address	Low address	High bytes	Low bytes	Number of data	Data byte 1	Data byte 2	CRC Low	CRC High
1~32	0x10	0x00	0x38	0x00	0x01	0x02	0~359 High 8-bit	0~359 Low 8-bit	Calculated based on the first 9 bytes	

1~32	0x10	0x00	0x39	0x00	0x01	0x02	0~359 High 8-bit	0~359 Low 8-bit	Calculated based on the first 9 bytes
------	------	------	------	------	------	------	------------------------	-----------------------	---

3) Return Instruction Format

Instrument address	Function Code	High Address	Low Address	High bytes	Low bytes	CRC Low	CRC High
1~32	0x10	0x00	0x39	0x00	0x01	Calculated based on the first 6 bytes	

6.4.2.57 Address 58 (Test Result)

1) Command Description

This command is used to set the result display mode in the programmed mode. Command is invalid when output is turned on. The instruction data byte bit corresponds to the function of the instrument as shown below:

Data Byte	Result Display Mode
0x00	This command is used to set the result display mode to LAST in programmed mode.
0x01	This command is used to set the result display mode to ALL in programmed mode.
0x02	This command is used to set the result display mode to P/F in

2) Send Instruction Format

Instrument address	Function code	High address	Low address	High bytes	Low bytes	Number of data	Data byte 1	Data byte 2	CRC Low	CRC High
1~32	0x10	0x00	0x3A	0x00	0x01	0x02	0x00	0x00 or 0x01 or 0x02	Calculated based on the first 8 bytes	

3) Return Instruction Format

Instrument address	Function Code	High Address	Low Address	High bytes	Low bytes	CRC Low	CRC High
1~32	0x10	0x00	0x3A	0x00	0x01	Calculated based on the first 6 bytes	

6.4.2.58 Address 59 (Surge Drop)

1) Command Description

This command is used to control the surge drop in the programmed mode. Command is invalid when output is turned on. The command data byte bit corresponds to the function of the instrument as shown below:

Data Byte	Step Connection
0x00	This command is used to turn off the surge drop in the program mode.
0x01	This command is used to turn on the surge drop in the program mode.

2) Send Instruction Format

Instrument address	Function code	High address	Low address	High bytes	Low bytes	Number of data	Data byte 1	Data byte 2	CRC Low	CRC High
1~32	0x10	0x00	0x3B	0x00	0x01	0x01	0x00	0x00 or 0x01	Calculated based on the first 9 bytes	

3) Return Instruction Format

Instrument address	Function Code	High Address	Low Address	High bytes	Low bytes	CRC Low	CRC High
1~32	0x10	0x00	0x3B	0x00	0x01	Calculated based on the first 6 bytes	

6.4.2.59 Address 60 (Over Current Fold)

1) Command Description

This command is used to control the over current fold function in the programmed mode. Command is invalid when output is turned on. The command data byte bit corresponds to the function of the instrument as shown below:

Data Byte	over current fold function
0x00	This command is used to turn off the over current fold function in the programmed mode.
0x01	This command is used to turn on the over current fold function in the programmed mode.

2) Send Instruction Format

Instrument address	Function code	High address	Low address	High bytes	Low bytes	Number of data	Data byte 1	Data byte 2	CRC Low	CRC High
1~32	0x10	0x00	0x3E	0x00	0x01	0x02	0x00	0x00 or 0x01	Calculated based on the first 8 bytes	

3) Return Instruction Format

Instrument address	Function Code	High Address	Low Address	High bytes	Low bytes	CRC Low	CRC High
1~32	0x10	0x00	0x3E	0x00	0x01	Calculated based on the first 6 bytes	

6.4.2.60 Address 61 (Total Circle Numbers)

1) Command Description

This command is used to set the total number of cycles of the memory sequence in the programmed mode. The command data range is from 0 to 999. Command is invalid when output is turned on.

2) Send Instruction Format

Instrument address	Function code	High address	Low address	High bytes	Low bytes	Number of data	Data byte 1	Data byte 2	CRC Low	CRC High
1~32	0x10	0x00	0x3F	0x00	0x01	0x02	0~999 High 8-bit	0~999 Low 8-bit	Calculated based on the first 9 bytes	

3) Return Instruction Format

Instrument address	Function Code	High Address	Low Address	High bytes	Low bytes	CRC Low	CRC High
1~32	0x10	0x00	0x3F	0x00	0x01	Calculated based on the first 6 bytes	

6.4.2.61 Address 62 (Single Step Test)

1) Command Description

This command is used to control the single step test function in the programmed mode. Command is invalid when output is turned on. The command data byte bit corresponds to the function of the instrument as shown below:

Data Byte	Over Current Fold Function
0x00	This command is used to turn off the single step test function in the program mode.
0x01	This command is used to turn off the single step test function in the program mode.

2) Send Instruction Format

Instrument address	Function code	High address	Low address	High bytes	Low bytes	Number of data	Data byte 1	Data byte 2	CRC Low	CRC High
--------------------	---------------	--------------	-------------	------------	-----------	----------------	-------------	-------------	---------	----------

1~32	0x10	0x00	0x40	0x00	0x01	0x02	0x00	0x00 or 0x01	Calculated based on the first 8 bytes
------	------	------	------	------	------	------	------	--------------------	---------------------------------------

3) Return Instruction Format

Instrument address	Function Code	High Address	Low Address	High bytes	Low bytes	CRC Low	CRC High
1~32	0x10	0x00	0x40	0x00	0x01	Calculated based on the first 6 bytes	

6.4.2.62 Address 63 (Exit Result Display)

1) Command Description

This command is used to exit the result display status. Command is invalid when output is turned on.

2) Send Instruction Format

Instrument address	Function code	High address	Low address	High bytes	Low bytes	Number of data	Data byte 1	Data byte 2	CRC Low	CRC High
1~32	0x10	0x00	0x41	0x00	0x01	0x02	0x00	0x00	Calculated based on the first 9 bytes	

3) Return Instruction Format

Instrument address	Function Code	High Address	Low Address	High bytes	Low bytes	CRC Low	CRC High
1~32	0x10	0x00	0x41	0x00	0x01	Calculated based on the first 6 bytes	

6.4.3 MODBUS Read Commands

6.4.3.1 Address 1 (Instrument Model)

1) Command Description

This command is used to query the model number of the instrument. The instrument models are TH7105, TH7110, TH7120.

2) Send Instruction Format

Instrument address	Function Code	High Address	Low Address	High bytes	Low bytes	CRC Low	CRC High
--------------------	---------------	--------------	-------------	------------	-----------	---------	----------

1~32	0x03	0x00	0x01	0x00	0x01	Calculated based on the first 6 bytes
------	------	------	------	------	------	---------------------------------------

3) Return Instruction Format

If the instrument model is TH7105, it returns 0x1BC1; if the instrument model is TH7110, it returns 0x1BC6; if the instrument model is TH7120, it returns 0x1BD0.

Instrument address	Function Code	Number of Data	Data Byte1	Data Byte2	CRC Low	CRC High
1~32	0x03	0x02	0x1B	0xC1	Calculated based on the first 5 bytes	
			0x1B	0xC6		
			0x1B	0xD0		

6.4.3.2 Address 2 (Output Switch)

1) Command Description

This command is used to query the status of the instrument output.

2) Send Instruction Format

Instrument address	Function Code	High Address	Low Address	High bytes	Low bytes	CRC Low	CRC High
1~32	0x03	0x00	0x02	0x00	0x01	Calculated based on the first 6 bytes	

3) Return Instruction Format

Data Byte returns 0 or 1. 0 indicates that the state of the instrument output is off; 1 indicates that the state of the instrument output is on.

Instrument address	Function Code	Number of Data	Data Byte1	Data Byte2	CRC Low	CRC High
1~32	0x03	0x02	0x00	0x00	Calculated based on the first 5 bytes	
				0x01		

6.4.3.3 Address 3 (Test Mode)

1) Command Description

This command is used to query the test mode.

2) Send Instruction Format

Instrument address	Function Code	High Address	Low Address	High bytes	Low bytes	CRC Low	CRC High
1~32	0x03	0x00	0x03	0x00	0x01	Calculated based on the first 6 bytes	

3) Return Instruction Format

Data Byte returns 0 or 1. 0 means the instrument's test mode is in manual mode; 1 means the instrument's test mode is in programmed mode.

Instrument address	Function Code	Number of Data	Data Byte1	Data Byte2	CRC Low	CRC High
1~32	0x03	0x02	0x00	0x00	Calculated based on the first 5 bytes	
				0x01		

6.4.3.4 Address 4 (Memory Sequence)

1) Command Description

This command is used to query the number of the memory sequence in manual mode.

2) Send Instruction Format

Instrument address	Function Code	High Address	Low Address	High bytes	Low bytes	CRC Low	CRC High
1~32	0x03	0x00	0x04	0x00	0x01	Calculated based on the first 6 bytes	

3) Return Instruction Format

The return command Data Byte ranges from 1 to 50.

Instrument address	Function Code	Number of Data	Data Byte1	Data Byte2	CRC Low	CRC High
1~32	0x03	0x02	0x00	1~50	Calculated based on the first 5 bytes	

6.4.3.5 Address 5 (Setting Voltage)

1) Command Description

This command is used to query the set voltage in manual mode.

2) Send Instruction Format

Instrument address	Function Code	High Address	Low Address	High bytes	Low bytes	CRC Low	CRC High
1~32	0x03	0x00	0x05	0x00	0x02	Calculated based on the first 6 bytes	

3) Return Instruction Format

The return command data byte range is 0.0~300.0V.

Instrument address	Function Code	Number of Data	Data Byte 1~4	CRC Low	CRC High
1~32	0x03	0x04	0.0~300.0, 4 bytes stored in float point type	Calculated based on the first 7 bytes	

6.4.3.6 Address 6 (Voltage Mode)

1) Command Description

This command is used to query the voltage output mode in the current manual mode.

2) Send Instruction Format

Instrument address	Function Code	High Address	Low Address	High bytes	Low bytes	CRC Low	CRC High
1~32	0x03	0x00	0x06	0x00	0x01	Calculated based on the first 6 bytes	

3) Return Instruction Format

Data byte returns 0 or 1. 0 means that the current output mode is AUTO in manual mode; 1 means that the voltage output mode is HIGH in the current manual mode.

Instrument address	Function Code	Number of Data	Data Byte1	Data Byte2	CRC Low	CRC High
1~32	0x03	0x00	0x00	0x00	Calculated based on the first 5 bytes	
				0x01		

6.4.3.7 Address 7 (Setting Frequency)

1) Command Description

This command is used to query the output frequency value in the current manual mode.

2) Send Instruction Format

Instrument address	Function Code	High Address	Low Address	High bytes	Low bytes	CRC Low	CRC High
1~32	0x03	0x00	0x07	0x00	0x02	Calculated based on the first 6 bytes	

3) Return Instruction Format

The return command data byte range is 45.0~500Hz. When the frequency is less than 100 Hz, the resolution is 0.1 Hz; when the frequency is not less than 100 Hz, the resolution is 1 Hz.

Instrument address	Function Code	Number of Data	Data Byte 1~4	CRC Low	CRC High
1~32	0x03	0x00	45.0~500, 4 bytes stored in float point type	Calculated based on the first 7 bytes	

6.4.3.8 Address 8 (Current High Limit)

1) Command Description

This command is used to query the current high limit value in the current manual mode.

2) Send Instruction Format

Instrument address	Function Code	High Address	Low Address	High bytes	Low bytes	CRC Low	CRC High
1~32	0x03	0x00	0x08	0x00	0x02	Calculated based on the first 6 bytes	

3) Return Instruction Format

When the set voltage is not greater than 150V, the return command data range is 0.000~8.400A; when the set voltage is greater than 150V, the return command data range is 0.000~4.200A.

Instrument address	Function Code	Number of Data	Data Byte 1~4	CRC Low	CRC High
1~32	0x03	0x00	0.000~4.200 or 0.000~8.400, 4 bytes stored in float point type	Calculated based on the first 7 bytes	

6.4.3.9 Address 9 (Current Low Limit)

1) Command Description

This command is used to query the current low limit value in the current manual mode.

2) Send Instruction Format

Instrument address	Function Code	High Address	Low Address	High bytes	Low bytes	CRC Low	CRC High
1~32	0x03	0x00	0x09	0x00	0x02	Calculated based on the first 6 bytes	

3) Return Instruction Format

When the set voltage is not greater than 150V, the return command data range is 0.000~8.400A; when the set voltage is greater than 150V, the return command data range is 0.000~4.200A.

Instrument address	Function Code	Number of Data	Data Byte 1~4	CRC Low	CRC High
1~32	0x03	0x00	0.000~4.200 or 0.000~8.400, 4 bytes stored in float point type	Calculated based on the first 7 bytes	

6.4.3.10 Address 10 (SD Voltage)

1) Command Description

This command is used to query the current voltage value of surge drop in the current manual mode.

2) Send Instruction Format

Instrument address	Function Code	High Address	Low Address	High bytes	Low bytes	CRC Low	CRC High
1~32	0x03	0x00	0x0A	0x00	0x04	Calculated based on the first 6 bytes	

3) Return Instruction Format

The return command data byte range is 0.0~300.0V.

Instrument address	Function Code	Number of Data	Data Byte 1~4	CRC Low	CRC High
1~32	0x03	0x00	0.0~300.0, 4 bytes stored in float point type	Calculated based on the first 7 bytes	

6.4.3.11 Address 11 (SD Location)

1) Command Description

This command is used to query the location of the surge drop in manual mode.

2) Send Instruction Format

Instrument address	Function Code	High Address	Low Address	High bytes	Low bytes	CRC Low	CRC High
1~32	0x03	0x00	0x0B	0x00	0x01	Calculated based on the first 6 bytes	

3) Return Instruction Format

The return command data byte range is 0--20.

Instrument address	Function Code	Number of Data	Data Byte1	Data Byte2	CRC Low	CRC High
1~32	0x03	0x00	0x00	0~20	Calculated based on the first 5 bytes	

6.4.3.12 Address 12 (SD Time)

1) Command Description

This command is used to query the time width of the surge drop in manual mode.

2) Send Instruction Format

Instrument address	Function Code	High Address	Low Address	High bytes	Low bytes	CRC Low	CRC High
1~32	0x03	0x00	0x0C	0x00	0x01	Calculated based on the first 6 bytes	

3) Return Instruction Format

The return command data byte range is 0--20.

Instrument address	Function Code	Number of Data	Data Byte1	Data Byte2	CRC Low	CRC High
1~32	0x03	0x00	0x00	0~20	Calculated based on the first 5 bytes	

6.4.3.13 Address 13 (SD Connection)

1) Command Description

This command is used to query the SD connection status of the surge drop in manual mode.

2) Send Instruction Format

Instrument address	Function Code	High Address	Low Address	High bytes	Low bytes	CRC Low	CRC High
--------------------	---------------	--------------	-------------	------------	-----------	---------	----------

1~32	0x03	0x00	0x0D	0x00	0x01	Calculated based on the first 6 bytes
------	------	------	------	------	------	---------------------------------------

3) Return Instruction Format

Data Byte returns 0 or 1. 0 means that the SD connection of the surge drop is off in manual mode; 1 means that the SD connection of the surge drop is turned on in manual mode.

Instrument address	Function Code	Number of Data	Data Byte1	Data Byte2	CRC Low	CRC High
1~32	0x03	0x02	0x00	0x00	Calculated based on the first 5 bytes	
				0x01		

6.4.3.14 Address 14 (Voltage High Limit)

1) Command Description

This command is used to query the high limit of the voltage in manual mode.

2) Send Instruction Format

Instrument address	Function Code	High Address	Low Address	High bytes	Low bytes	CRC Low	CRC High
1~32	0x03	0x00	0x0E	0x00	0x02	Calculated based on the first 6 bytes	

3) Return Instruction Format

The return command data range is 0.0~300.0V.

Instrument address	Function Code	Number of Data	Data Byte 1~4	CRC Low	CRC High
1~32	0x03	0x04	0.0~300.0, 4 bytes stored in float point type	Calculated based on the first 7 bytes	

6.4.3.15 Address 15 (Voltage Low Limit)

1) Command Description

This command is used to query the low limit of the voltage in manual mode.

2) Send Instruction Format

Instrument address	Function Code	High Address	Low Address	High bytes	Low bytes	CRC Low	CRC High
--------------------	---------------	--------------	-------------	------------	-----------	---------	----------

1~32	0x03	0x00	0x0F	0x00	0x02	Calculated based on the first 6 bytes
------	------	------	------	------	------	---------------------------------------

3) Return Instruction Format

The return command data range is 0.0~300.0V.

Instrument address	Function Code	Number of Data	Data Byte 1~4	CRC Low	CRC High
1~32	0x03	0x04	0.0~300.0, 4 bytes stored in float point type	Calculated based on the first 7 bytes	

6.4.3.16 Address 16 (Frequency High Limit)

1) Command Description

This command is used to query the frequency high limit in manual mode.

2) Send Instruction Format

Instrument address	Function Code	High Address	Low Address	High bytes	Low bytes	CRC Low	CRC High
1~32	0x03	0x00	0x10	0x00	0x02	Calculated based on the first 6 bytes	

3) Return Instruction Format

The return command data range is 45.0~500Hz. When the frequency is less than 100 Hz, the resolution is 0.1 Hz; when the frequency is not less than 100 Hz, the resolution is 1 Hz.

Instrument address	Function Code	Number of Data	Data Byte 1~4	CRC Low	CRC High
1~32	0x03	0x04	45.0~500, 4 bytes stored in float point type	Calculated based on the first 7 bytes	

6.4.3.17 Address 17 (Frequency Low Limit)

1) Command Description

This command is used to query the frequency high limit in manual mode.

2) Send Instruction Format

Instrument address	Function Code	High Address	Low Address	High bytes	Low bytes	CRC Low	CRC High
--------------------	---------------	--------------	-------------	------------	-----------	---------	----------

1~32	0x03	0x00	0x11	0x00	0x02	Calculated based on the first 6 bytes
------	------	------	------	------	------	---------------------------------------

3) Return Instruction Format

The return command data range is 45.0~500Hz. When the frequency is less than 100 Hz, the resolution is 0.1 Hz; when the frequency is not less than 100 Hz, the resolution is 1 Hz.

Instrument address	Function Code	Number of Data	Data Byte 1~4	CRC Low	CRC High
1~32	0x03	0x04	45.0~500, 4 bytes stored in float point type	Calculated based on the first 7 bytes	

6.4.3.18 Address 18 (Starting Angle)

1) Command Description

This command is used to query the starting angle in manual mode.

2) Send Instruction Format

Instrument address	Function Code	High Address	Low Address	High bytes	Low bytes	CRC Low	CRC High
1~32	0x03	0x00	0x12	0x00	0x02	Calculated based on the first 6 bytes	

3) Return Instruction Format

Return data range is 0~359.

Instrument address	Function Code	Number of Data	Data Byte1	Data Byte2	CRC Low	CRC High
1~32	0x03	0x02	0~359 High 8-bit	0~359 Low 8-bit	Calculated based on the first 5 bytes	

6.4.3.19 Address 19 (End Angle)

1) Command Description

This command is used to query the starting angle in manual mode.

2) Send Instruction Format

Instrument address	Function Code	High Address	Low Address	High bytes	Low bytes	CRC Low	CRC High
--------------------	---------------	--------------	-------------	------------	-----------	---------	----------

1~32	0x03	0x00	0x13	0x00	0x02	Calculated based on the first 6 bytes
------	------	------	------	------	------	---------------------------------------

3) Return Instruction Format

Return command data range is 0~359

Instrument address	Function Code	Number of Data	Data Byte1	Data Byte2	CRC Low	CRC High
1~32	0x03	0x02	0~359 High 8-bit	0~359 Low 8-bit	Calculated based on the first 5 bytes	

6.4.3.20 Address 20 (Test Result)

1) Command Description

This command is used to query the result display mode in manual mode.

2) Send Instruction Format

Instrument address	Function Code	High Address	Low Address	High bytes	Low bytes	CRC Low	CRC High
1~32	0x03	0x00	0x14	0x00	0x01	Calculated based on the first 6 bytes	

3) Return Instruction Format

The return instruction data is 0x00 or 0x01 or 0x02. When the return command data is 0x00, it means that the result display mode is NONE in the manual mode. When the return command data is 0x01, it means that the result display mode is LAST in manual mode; when the return command data is 0x02, it means that the result display mode is ALL in manual mode; when the return command data is 0x03, it means that the result display mode is P/F in manual mode.

Instrument address	Function Code	Number of Data	Data Byte1	Data Byte2	CRC Low	CRC High
1~32	0x03	0x02	0x01	0x00	Calculated based on the first 8 bytes	
				0x01		
				0x02		
				0x03		

6.4.3.21 Address 21 (Surge Drop)

1) Command Description

This command is used to query the state of the surge drop in manual mode.

2) Send Instruction Format

Instrument address	Function Code	High Address	Low Address	High bytes	Low bytes	CRC Low	CRC High
1~32	0x03	0x00	0x15	0x00	0x01	Calculated based on the first 6 bytes	

3) Return Instruction Format

Data byte returns 0 or 1. 0 indicates that the surge drop is off in manual mode; 1 indicates that the glitch trap is on in manual mode.

Instrument address	Function Code	Number of Data	Data Byte1	Data Byte2	CRC Low	CRC High
1~32	0x03	0x02	0x00	0x00	Calculated based on the first 5 bytes	
				0x01		

6.4.3.22 Address 22 (Over Current Fold)

1) Command Description

This command is used to query the state of over current fold in manual mode.

2) Send Instruction Format

Instrument address	Function Code	High Address	Low Address	High bytes	Low bytes	CRC Low	CRC High
1~32	0x03	0x00	0x16	0x00	0x01	Calculated based on the first 6 bytes	

3) Return Instruction Format

Data byte returns 0 or 1. 0 means that the over current fold is turned off in the manual mode; 1 means that the over current is turned on in the manual mode.

Instrument address	Function Code	Number of Data	Data Byte1	Data Byte2	CRC Low	CRC High
1~32	0x03	0x02	0x00	0x00	Calculated based on the first 5 bytes	
				0x01		

6.4.3.23 Address 23 (Voltage Restriction)

1) Command Description

This command is used to query the allowable voltage difference between the set voltage and the output

voltage in manual mode.

2) Send Instruction Format

Instrument address	Function Code	High Address	Low Address	High bytes	Low bytes	CRC Low	CRC High
1~32	0x03	0x00	0x17	0x00	0x02	Calculated based on the first 6 bytes	

3) Return Instruction Format

Return instruction data range is 5.0~50.0V.

Instrument address	Function Code	Number of Data	Data Byte 1~4	CRC Low	CRC High
1~32	0x03	0x04	5.0~50.0, 4 bytes stored in float point type	Calculated based on the first 7 bytes	

6.4.3.24 Address 24 (Timer Second)

1) Command Description

This command is used to query the number of seconds of timer in the manual mode.

2) Send Instruction Format

Instrument address	Function Code	High Address	Low Address	High bytes	Low bytes	CRC Low	CRC High
1~32	0x03	0x00	0x18	0x00	0x01	Calculated based on the first 6 bytes	

3) Return Instruction Format

Return instruction data byte range is 0~59.

Instrument address	Function Code	Number of Data	Data Byte1	Data Byte2	CRC Low	CRC High
1~32	0x03	0x02	0x00	0~59	Calculated based on the first 5 bytes	

6.4.3.25 Address 25 (Timer Minutes)

1) Command Description

This command is used to query the number of minutes of timer in the manual mode.

2) Send Instruction Format

Instrument address	Function Code	High Address	Low Address	High bytes	Low bytes	CRC Low	CRC High
1~32	0x03	0x00	0x19	0x00	0x01	Calculated based on the first 6 bytes	

3) Return Instruction Format

Return instruction data byte range is 0~59.

Instrument address	Function Code	Number of Data	Data Byte1	Data Byte2	CRC Low	CRC High
1~32	0x03	0x02	0x05	0~59	Calculated based on the first 5 bytes	

6.4.3.26 Address 26 (Timer Hour)

1) Command Description

This command is used to query the number of hours of timer in the manual mode.

2) Send Instruction Format

Instrument address	Function Code	High Address	Low Address	High bytes	Low bytes	CRC Low	CRC High
1~32	0x03	0x00	0x1A	0x00	0x01	Calculated based on the first 6 bytes	

3) Return Instruction Format

Return instruction data byte range is 0~99.

Instrument address	Function Code	Number of Data	Data Byte1	Data Byte2	CRC Low	CRC High
1~32	0x03	0x02	0x00	0~99	Calculated based on the first 5 bytes	

6.4.3.27 Address 27 (Memory Sequence)

1) Command Description

This command is used to query the serial number of the memory sequence in the programmed mode.

2) Send Instruction Format

Instrument address	Function Code	High Address	Low Address	High bytes	Low bytes	CRC Low	CRC High
--------------------	---------------	--------------	-------------	------------	-----------	---------	----------

1~32	0x03	0x00	0x1B	0x00	0x01	Calculated based on the first 6 bytes
------	------	------	------	------	------	---------------------------------------

3) Return Instruction Format

Return instruction data byte range is 1~50.

Instrument address	Function Code	Number of Data	Data Byte1	Data Byte2	CRC Low	CRC High
1~32	0x03	0x02	0x00	1~50	Calculated based on the first 5 bytes	

6.4.3.28 Address 28 (Sequence Frequency)

1) Command Description

This command is used to query the number of sequences in the programmed mode.

2) Send Instruction Format

Instrument address	Function Code	High Address	Low Address	High bytes	Low bytes	CRC Low	CRC High
1~32	0x03	0x00	0x1C	0x00	0x01	Calculated based on the first 6 bytes	

3) Return Instruction Format

Return instruction data range is 0~999.

Instrument address	Function Code	Number of Data	Data Byte1	Data Byte2	CRC Low	CRC High
1~32	0x03	0x02	0~999 High 8-bit	0~999 Low 8-bit	Calculated based on the first 5 bytes	

6.4.3.29 Address 29 (Step)

1) Command Description

This command is used to query the serial number of the steps in the programmed mode.

2) Send Instruction Format

Instrument address	Function Code	High Address	Low Address	High bytes	Low bytes	CRC Low	CRC High
1~32	0x03	0x00	0x1D	0x00	0x01	Calculated based on the first 6 bytes	

3) Return Instruction Format

Return instruction data byte range is 1~9.

Instrument address	Function Code	Number of Data	Data Byte1	Data Byte2	CRC Low	CRC High
1~32	0x03	0x02	0x00	1~9	Calculated based on the first 5 bytes	

6.4.3.30 Address 30 (Step Frequency)

1) Command Description

This command is used to query the number of steps in the programmed mode.

2) Send Instruction Format

Instrument address	Function Code	High Address	Low Address	High bytes	Low bytes	CRC Low	CRC High
1~32	0x03	0x00	0x1E	0x00	0x01	Calculated based on the first 6 bytes	

3) Return Instruction Format

Return instruction data range is 0~999.

Instrument address	Function Code	Number of Data	Data Byte1	Data Byte2	CRC Low	CRC High
1~32	0x03	0x02	0~999 High 8-bit	0~999 Low 8-bit	Calculated based on the first 5 bytes	

6.4.3.31 Address 31 (Set Voltage)

1) Command Description

This command is used to query the set voltage of the current step in the programmed mode.

2) Send Instruction Format

Instrument address	Function Code	High Address	Low Address	High bytes	Low bytes	CRC Low	CRC High
1~32	0x03	0x00	0x1F	0x00	0x02	Calculated based on the first 6 bytes	

3) Return Instruction Format

Return instruction data range is 0.0--300.0V

Instrument address	Function Code	Number of Data	Data Byte 1~4	CRC Low	CRC High
--------------------	---------------	----------------	---------------	---------	----------

1~32	0x03	0x04	0.0~300.0, 4 bytes stored in float point type	Calculated based on the first 7 bytes
------	------	------	---	---------------------------------------

6.4.3.32 Address 32 (Voltage Mode)

1) Command Description

This command is used to query the voltage output mode of the current step in the programmed mode.

2) Send Instruction Format

Instrument address	Function Code	High Address	Low Address	High bytes	Low bytes	CRC Low	CRC High
1~32	0x03	0x00	0x20	0x00	0x01	Calculated based on the first 6 bytes	

3) Return Instruction Format

Data Byte returns 0 or 1.0 means the voltage output mode is AUTO in the current programming mode; 1 means the voltage output mode is HIGH in the current programmed mode.

Instrument address	Function Code	Number of Data	Data Byte1	Data Byte2	CRC Low	CRC High
1~32	0x03	0x02	0x00	0x00	Calculated based on the first 5 bytes	
				0x01		

6.4.3.33 Address 33 (Current High Limit)

1) Command Description

This command is used to query the current high limit of the current step in the programmed mode.

2) Send Instruction Format

Instrument address	Function Code	High Address	Low Address	High bytes	Low bytes	CRC Low	CRC High
1~32	0x03	0x00	0x21	0x00	0x02	Calculated based on the first 6 bytes	

3) Return Instruction Format

When the set voltage is not greater than 150V, the return command data range is 0.000~8.400A; when the set voltage is greater than 150V, the return command data range is 0.000~4.200A. When this parameter returns to 0.000, it means that this function is off.

Instrument address	Function Code	Number of Data	Data Byte 1~4	CRC Low	CRC High
1~32	0x03	0x04	0.000~4.200 or 0.000~8.400, 4 bytes stored in float point type	Calculated based on the first 7 bytes	

6.4.3.34 Address34 (Current Low Limit)

1) Command Description

This command is used to query the current low limit of the current step in the programmed mode.

2) Send Instruction Format

Instrument address	Function Code	High Address	Low Address	High bytes	Low bytes	CRC Low	CRC High
1~32	0x03	0x00	0x22	0x00	0x02	Calculated based on the first 6 bytes	

3) Return Instruction Format

When the set voltage is not greater than 150V, the return command data range is 0.000~8.400A; when the set voltage is greater than 150V, the return command data range is 0.000~4.200A. When this parameter returns to 0.000, it means that this function is off.

Instrument address	Function Code	Number of Data	Data Byte 1~4	CRC Low	CRC High
1~32	0x03	0x04	0.000~4.200 or 0.000~8.400, 4 bytes stored in float point type	Calculated based on the first 7 bytes	

6.4.3.35 Address 35 (Set Frequency)

1) Command Description

This command is used to query the output frequency value of the current step in the programmed mode.

2) Send Instruction Format

Instrument address	Function Code	High Address	Low Address	High bytes	Low bytes	CRC Low	CRC High
1~32	0x03	0x00	0x23	0x00	0x02	Calculated based on the first 6 bytes	

3) Return Instruction Format

Return instruction data byte range is 45.0~500Hz。 When frequency is less than 100Hz, the resolution is 0.1Hz; When frequency is not less than 100Hz, the resolution is 1 Hz.

Instrument address	Function Code	Number of Data	Data Byte 1~4	CRC Low	CRC High
1~32	0x03	0x04	45.0~500, 4 bytes stored in float point type	Calculated based on the first 7 bytes	

6.4.3.36 Address 36 (Step Connection)

1) Command Description

This command is used to query the status of the step connection of the current step in the programmed mode.

2) Send Instruction Format

Instrument address	Function Code	High Address	Low Address	High bytes	Low bytes	CRC Low	CRC High
1~32	0x03	0x00	0x24	0x00	0x01	Calculated based on the first 6 bytes	

3) Return Instruction Format

Data byte returns 0 or 1. 0 means that the step connection of the current step in the programmed mode is off; 1 means that the step of the current step in the programmed mode is connected to the open state.

Instrument address	Function Code	Number of Data	Data Byte1	Data Byte2	CRC Low	CRC High
1~32	0x03	0x02	0x00	0x00	Calculated based on the first 5 bytes	
				0x01		

6.4.3.37 Address 37 (AP HiLmt)

1) Command Description

This command is used to query the peak current high limit value of the current step in the programmed mode.

2) Send Instruction Format

Instrument address	Function Code	High Address	Low Address	High bytes	Low bytes	CRC Low	CRC High
--------------------	---------------	--------------	-------------	------------	-----------	---------	----------

1~32	0x03	0x00	0x25	0x00	0x02	Calculated based on the first 6 bytes
------	------	------	------	------	------	---------------------------------------

3) Return Instruction Format

When the voltage mode is "AUTO" and the voltage is less than 150V, the range is 0.0~33.6A; when the voltage mode is "AUTO" and the voltage is greater than 150V or the voltage mode is "HIGH", the range is 0.0~16.8A. When this parameter returns to 0.0, it means that this feature is off.

Instrument address	Function Code	Data Byte 1~4	CRC Low	CRC High
1~32	0x04	0.0~16.8 or 0.0~33.6, 4 bytes stored in float point type	Calculated based on the first 7 bytes	

6.4.3.38 Address 38 (AP LoLmt)

1) Command Description

This command is used to query the peak current low limit value of the current step in the programmed mode.

2) Send Instruction Format

Instrument address	Function Code	High Address	Low Address	High bytes	Low bytes	CRC Low	CRC High
1~32	0x03	0x00	0x26	0x00	0x02	Calculated based on the first 6 bytes	

3) Return Instruction Format

When the voltage mode is "AUTO" and the voltage is less than 150V, the range is 0.0~33.6A; when the voltage mode is "AUTO" and the voltage is greater than 150V or the voltage mode is "HIGH", the range is 0.0~16.8A. When this parameter returns to 0.0, it means that this feature is off.

Instrument address	Function Code	Number of Data	Data Byte 1~4	CRC Low	CRC High
1~32	0x03	0x04	0.0~16.8 or 0.0~33.6, 4 bytes stored in float point type	Calculated based on the first 7 bytes	

6.4.3.39 Address 39 (Power High Limit)

1) Command Description

This command is used to query the power high limit of the current step in the programmed mode.

2) Send Instruction Format

Instrument address	Function Code	High Address	Low Address	High bytes	Low bytes	CRC Low	CRC High
1~32	0x03	0x00	0x27	0x00	0x02	Calculated based on the first 6 bytes	

3) Return Instruction Format

The return instruction data range is 0.0~1000. When it returns 0.0, it means this function is turned off.

Instrument address	Function Code	Number of Data	Data Byte 1~4	CRC Low	CRC High
1~32	0x03	0x04	0.0~1000, 4 bytes stored in float point type	Calculated based on the first 7 bytes	

6.4.3.40 Address 40 (Power Low Limit)

1) Command Description

This command is used to query the power low limit of the current step in the programmed mode.

2) Send Instruction Format

Instrument address	Function Code	High Address	Low Address	High bytes	Low bytes	CRC Low	CRC High
1~32	0x03	0x00	0x28	0x00	0x02	Calculated based on the first 6 bytes	

3) Return Instruction Format

The return instruction data range is 0.0~1000. When it returns 0.0, it means this function is turned off.

Instrument address	Function Code	Number of Data	Data Byte 1~4	CRC Low	CRC High
1~32	0x03	0x04	0.0~1000, 4 bytes stored in float point type	Calculated based on the first 7 bytes	

6.4.3.41 Address 41 (PF High Limit)

1) Command Description

This command is used to query the high limit of the power factor of the current step in the programmed mode.

2) Send Instruction Format

Instrument address	Function Code	High Address	Low Address	High bytes	Low bytes	CRC Low	CRC High
1~32	0x03	0x00	0x29	0x00	0x02	Calculated based on the first 6 bytes	

3) Return Instruction Format

The return instruction data range is 0.000~1000. When it returns 0.000, it means this function is turned off.

Instrument address	Function Code	Number of Data	Data Byte 1~4	CRC Low	CRC High
1~32	0x03	0x04	0.000~1.000, 4 bytes stored in float point type	Calculated based on the first 7 bytes	

6.4.3.42 Address 42 (PF Low Limit)

1) Command Description

This command is used to query the low limit of the power factor of the current step in the programmed mode.

2) Send Instruction Format

Instrument address	Function Code	High Address	Low Address	High bytes	Low bytes	CRC Low	CRC High
1~32	0x03	0x00	0x2A	0x00	0x02	Calculated based on the first 6 bytes	

3) Return Instruction Format

The return instruction data range is 0.000~1000. When it returns 0.000, it means this function is turned off.

Instrument address	Function Code	Number of Data	Data Byte 1~4	CRC Low	CRC High
1~32	0x03	0x04	0.000~1.000, 4 bytes stored in float point type	Calculated based on the first 7 bytes	

6.4.3.43 Address 43 (Time Unit)

1) Command Description

This command is used to query the time unit of the current step in the programmed mode.

2) Send Instruction Format

Instrument address	Function Code	High Address	Low Address	High bytes	Low bytes	CRC Low	CRC High
1~32	0x03	0x00	0x2B	0x00	0x01	Calculated based on the first 6 bytes	

3) Return Instruction Format

The return instruction data is 0x00 or 0x01 or 0x02. When the return command data is 0x00, it means that the time unit of the current step in the programmed mode is seconds; when the return command data is 0x01, it means that the time unit of the current step is the minute in the programmed mode; when the return command data is 0x02, it means that the current mode is in the programmed mode. The time unit of the step is time.

Instrument address	Function Code	Number of Data	Data Byte1	Data Byte2	CRC Low	CRC High
1~32	0x03	0x02	0x01	0x00	Calculated based on the first 5 bytes	
				0x01		
				0x02		

6.4.3.44 Address 44 (Delay Time)

1) Command Description

This command is used to query the delay judgment time of the current step in the programmed mode.

2) Send Instruction Format

Instrument address	Function Code	High Address	Low Address	High bytes	Low bytes	CRC Low	CRC High
1~32	0x03	0x00	0x2C	0x00	0x02	Calculated based on the first 6 bytes	

3) Return Instruction Format

The return instruction data range is from 0.1 to 999.9. When the time unit is second, the value is 0.1~999.9s; when the time unit is minute, the value is 0.1~999.9m; when the time unit is time, the value is 0.1~999.9h.

Instrument address	Function Code	Number of Data	Data Byte 1~4	CRC Low	CRC High
1~32	0x03	0x04	0.1~999.9, 4 bytes stored in float point type	Calculated based on the first 7 bytes	

6.4.3.45 Address 45 (Test Time)

1) Command Description

This command is used to query the test time of the current step in the programmed mode.

2) Send Instruction Format

Instrument address	Function Code	High Address	Low Address	High bytes	Low bytes	CRC Low	CRC High
1~32	0x03	0x00	0x2D	0x00	0x02	Calculated based on the first 6 bytes	

3) Return Instruction Format

The return instruction data range is from 0.1 to 999.9. When the time unit is second, the value is 0.1~999.9s; when the time unit is minute, the value is 0.1~999.9m; when the time unit is time, the value is 0.1~999.9h.

Instrument address	Function Code	Number of Data	Data Byte 1~4	CRC Low	CRC High
1~32	0x03	0x04	0.1~999.9, 4 bytes stored in float point type	Calculated based on the first 7 bytes	

6.4.3.46 Address 46 (Rise Time)

1) Command Description

This command is used to query the rise time of the current step in the programmed mode.

2) Send Instruction Format

Instrument address	Function Code	High Address	Low Address	High bytes	Low bytes	CRC Low	CRC High
1~32	0x03	0x00	0x2E	0x00	0x02	Calculated based on the first 6 bytes	

3) Return Instruction Format

Return instruction data range is 0.1~999.9s.

Instrument address	Function Code	Number of Data	Data Byte 1~4	CRC Low	CRC High
1~32	0x03	0x04	0.1~999.9, 4 bytes stored in float point type	Calculated based on the first 7 bytes	

6.4.3.47 Address 47 (Fall Time)

1) Command Description

This command is used to query the fall time of the current step in the programmed mode.

2) Send Instruction Format

Instrument address	Function Code	High Address	Low Address	High bytes	Low bytes	CRC Low	CRC High
1~32	0x03	0x00	0x2F	0x00	0x02	Calculated based on the first 6 bytes	

3) Return Instruction Format

Return instruction data range is 0.1~999.9s.

Instrument address	Function Code	Number of Data	Data Byte 1~4	CRC Low	CRC High
1~32	0x03	0x04	0.1~999.9, 4 bytes stored in float point type	Calculated based on the first 7 bytes	

6.4.3.48 Address 48 (SD Voltage)

1) Command Description

This command is used to query the voltage value of the surge or drop at the current step in the programmed mode.

2) Send Instruction Format

Instrument address	Function Code	High Address	Low Address	High bytes	Low bytes	CRC Low	CRC High
1~32	0x03	0x00	0x30	0x00	0x02	Calculated based on the first 6 bytes	

3) Return Instruction Format

Return instruction data byte range is 0.0~300.0V.

Instrument address	Function Code	Number of Data	Data Byte 1~4	CRC Low	CRC High
1~32	0x03	0x04	0.0~300.0, 4 bytes stored in float point type	Calculated based on the first 7 bytes	

6.4.3.49 Address 49 (SD Location)

1) Command Description

This command is used to query the location of the surge or drop of the current step in the programmed mode.

2) Send Instruction Format

Instrument address	Function Code	High Address	Low Address	High bytes	Low bytes	CRC Low	CRC High
1~32	0x03	0x00	0x31	0x00	0x01	Calculated based on the first 6 bytes	

3) Return Instruction Format

Return instruction data byte range is 0~20

Instrument address	Function Code	Number of Data	Data Byte1	Data Byte2	CRC Low	CRC High
1~32	0x03	0x02	0x00	0~20	Calculated based on the first 5 bytes	

6.4.3.50 Address 50 (SD Time)

1) Command Description

This command is used to query the time width of the glitch or notch of the current step in the programmed mode.

2) Send Instruction Format

Instrument address	Function Code	High Address	Low Address	High bytes	Low bytes	CRC Low	CRC High
1~32	0x03	0x00	0x32	0x00	0x01	Calculated based on the first 6 bytes	

3) Return Instruction Format

Return instruction data byte range is 0~20

Instrument address	Function Code	Number of Data	Data Byte1	Data Byte2	CRC Low	CRC High
1~32	0x03	0x02	0x00	0~20	Calculated based on the first 5 bytes	

6.4.3.51 Address 51 (SD Connection)

1) Command Description

This command is used to query the connection status of the glitch or notch of the current step in the programmed mode.

2) Send Instruction Format

Instrument address	Function Code	High Address	Low Address	High bytes	Low bytes	CRC Low	CRC High
1~32	0x03	0x00	0x33	0x00	0x01	Calculated based on the first 6 bytes	

3) Return Instruction Format

Data byte returns 0 or 1. 0 means that the SD connection of the glitch trap is off in the programmed mode; 1 means that the SD connection of the glitch trap is turned on in the programmed mode.

Instrument address	Function Code	Number of Data	Data Byte1	Data Byte2	CRC Low	CRC High
1~32	0x03	0x00	0x00	0x00	Calculated based on the first 5 bytes	
				0x01		

6.4.3.52 Address 52 (Voltage High Limit)

1) Command Description

This command is used to query the upper limit of the voltage in the programmed mode.

2) Send Instruction Format

Instrument address	Function Code	High Address	Low Address	High bytes	Low bytes	CRC Low	CRC High
1~32	0x03	0x00	0x34	0x00	0x02	Calculated based on the first 6 bytes	

3) Return Instruction Format

The return instruction data range is 0.0~300.0V. When this parameter returns to 0.0, it means that this feature is turned off.

Instrument address	Function Code	Number of Data	Data Byte 1~4	CRC Low	CRC High
1~32	0x03	0x04	0.0~300.0, 4 bytes stored in float point type	Calculated based on the first 7 bytes	

6.4.3.53 Address 53 (Voltage Low Limit)

1) Command Description

This command is used to query the low limit of the voltage in the programmed mode.

2) Send Instruction Format

Instrument address	Function Code	High Address	Low Address	High bytes	Low bytes	CRC Low	CRC High
1~32	0x03	0x00	0x35	0x00	0x02	Calculated based on the first 6 bytes	

3) Return Instruction Format

The return instruction data range is 0.0~300.0V. When this parameter returns to 0.0, it means that this feature is turned off.

Instrument address	Function Code	Number of Data	Data Byte 1~4	CRC Low	CRC High
1~32	0x03	0x04	0.0~300.0, 4 bytes stored in float point type	Calculated based on the first 7 bytes	

6.4.3.54 Address 54 (Frequency High Limit)

1) Command Description

This command is used to query the upper frequency limit value in the programmed mode.

2) Send Instruction Format

Instrument address	Function Code	High Address	Low Address	High bytes	Low bytes	CRC Low	CRC High
1~32	0x03	0x00	0x36	0x00	0x02	Calculated based on the first 6 bytes	

3) Return Instruction Format

The return instruction data range is 0 or 45.0~500Hz. When the frequency is less than 100 Hz, the resolution is 0.1 Hz; when the frequency is not less than 100 Hz, the resolution is 1 Hz. When this parameter returns to 0.0, it means that this feature is turned off.

Instrument address	Function Code	Number of Data	Data Byte 1~4	CRC Low	CRC High
1~32	0x03	0x04	0 or 45.0~500, 4 bytes stored in float point type	Calculated based on the first 7 bytes	

6.4.3.55 Address 55 (Frequency Low Limit)

1) Command Description

This command is used to query the low frequency limit value in the programmed mode.

2) Send Instruction Format

Instrument address	Function Code	High Address	Low Address	High bytes	Low bytes	CRC Low	CRC High
1~32	0x03	0x00	0x37	0x00	0x02	Calculated based on the first 6 bytes	

3) Return Instruction Format

The return instruction data range is 0 or 45.0~500Hz. When the frequency is less than 100 Hz, the resolution is 0.1 Hz; when the frequency is not less than 100 Hz, the resolution is 1 Hz. When this parameter returns to 0.0, it means that this feature is turned off.

Instrument address	Function Code	Number of Data	Data Byte 1~4	CRC Low	CRC High
1~32	0x03	0x04	0 or 45.0~500, 4 bytes stored in float point type	Calculated based on the first 7 bytes	

6.4.3.56 Address 56 (Starting Angle)

1) Command Description

This command is used to query the starting angle in the programmed mode.

2) Send Instruction Format

Instrument address	Function Code	High Address	Low Address	High bytes	Low bytes	CRC Low	CRC High
1~32	0x03	0x00	0x38	0x00	0x01	Calculated based on the first 6 bytes	

3) Return Instruction Format

Return instruction data range is 0~359

Instrument address	Function Code	Number of Data	Data Byte1	Data Byte2	CRC Low	CRC High
1~32	0x03	0x02	0~359 High 8-bit	0~359 Low 8-bit	Calculated based on the first 5 bytes	

6.4.3.57 Address 57 (End Angle)

1) Command Description

This command is used to query the termination angle in the programmed mode.

2) Send Instruction Format

Instrument address	Function Code	High Address	Low Address	High bytes	Low bytes	CRC Low	CRC High
1~32	0x03	0x00	0x39	0x00	0x01	Calculated based on the first 6 bytes	

3) Return Instruction Format

Return instruction data range is 0~359.

Instrument address	Function Code	Number of Data	Data Byte1	Data Byte2	CRC Low	CRC High
1~32	0x03	0x02	0~359 High 8-bit	0~359 Low 8-bit	Calculated based on the first 5 bytes	

6.4.3.58 Address 58 (Test Result)

1) Command Description

This command is used to query the result display mode in the programmed mode.

2) Send Instruction Format

Instrument address	Function Code	High Address	Low Address	High bytes	Low bytes	CRC Low	CRC High
1~32	0x03	0x00	0x3A	0x00	0x01	Calculated based on the first 6 bytes	

3) Return Instruction Format

The return instruction data is 0x00 or 0x01 or 0x02. When the return command data is 0x00, it means that the result display mode is LAST in the programmed mode; when the return command data is 0x01, it means that the result display mode is ALL in the programmed mode; when the return command data is 0x02, it means that the result display mode is P/F in the programmed mode.

Instrument address	Function Code	Number of Data	Data Byte1	Data Byte2	CRC Low	CRC High
1~32	0x03	0x02	0x00	0x00	Calculated based on the first 5 bytes	
				0x01		
				0x02		

6.4.3.59 Address 59 (Surge Drop)

1) Command Description

This command is used to query the state of the glitch trap in the programmed mode.

2) Send Instruction Format

Instrument address	Function Code	High Address	Low Address	High bytes	Low bytes	CRC Low	CRC High
1~32	0x03	0x00	0x3B	0x00	0x01	Calculated based on the first 6 bytes	

3) Return Instruction Format

Data byte returns 0 or 1. 0 indicates that the glitch trap is off in the programmed mode; 1 indicates that the glitch trap is on in the programmed mode.

Instrument address	Function Code	Number of Data	Data Byte1	Data Byte2	CRC Low	CRC High
1~32	0x03	0x02	0x00	0x00	Calculated based on the first 5 bytes	
				0x01		

6.4.3.60 Address 60 (Over Current Fold)

1) Command Description

This command is used to query the state of constant over current in the programmed mode.

2) Send Instruction Format

Instrument address	Function Code	High Address	Low Address	High bytes	Low bytes	CRC Low	CRC High
1~32	0x03	0x00	0x3C	0x00	0x01	Calculated based on the first 6 bytes	

3) Return Instruction Format

Data byte returns 0 or 1. 0 means that the over current is always off in the programmed mode; 1 means that the over current is always on in the programmed mode.

Instrument address	Function Code	Number of Data	Data Byte1	Data Byte2	CRC Low	CRC High
1~32	0x03	0x02	0x00	0x00	Calculated based on the first 5 bytes	
				0x01		

6.4.3.61 Address 61 (Total Circle Numbers)

1) Command Description

This command is used to query the total number of cycles of the memory sequence in the programmed mode.

2) Send Instruction Format

Instrument address	Function Code	High Address	Low Address	High bytes	Low bytes	CRC Low	CRC High
1~32	0x03	0x00	0x3D	0x00	0x01	Calculated based on the first 6 bytes	

3) Return Instruction Format

Return instruction data range is 0~999

Instrument address	Function Code	Number of Data	Data Byte1	Data Byte2	CRC Low	CRC High
1~32	0x03	0x02	0~999 High 8-bit	0~999 Low 8-bit	Calculated based on the first 5 bytes	

6.4.3.62 Address 62 (Single Step Test)

1) Command Description

This command is used to query the single-step test status in the programmed mode.

2) Send Instruction Format

Instrument address	Function Code	High Address	Low Address	High bytes	Low bytes	CRC Low	CRC High
1~32	0x03	0x00	0x3E	0x00	0x01	Calculated based on the first 6 bytes	

3) Return Instruction Format

Data byte returns 0 or 1. 0 means that the single-step test status is off in the programmed mode; 1 means that the single-step test status is on in the programmed mode.

Instrument address	Function Code	Number of Data	Data Byte1	Data Byte2	CRC Low	CRC High
1~32	0x03	0x02	0x00	0x00	Calculated based on the first 5 bytes	
				0x01		

6.4.3.63 Address 64 (Output Voltage)

1) Command Description

This command is used to obtain the output voltage. The command is valid when the output is turned on.

2) Send Instruction Format

Instrument address	Function Code	High Address	Low Address	High bytes	Low bytes	CRC Low	CRC High
1~32	0x03	0x00	0x40	0x00	0x02	Calculated based on the first 6 bytes	

3) Return Instruction Format

Return instruction data range is 0.0~300.0V

Instrument address	Function Code	Number of Data	Data Byte 1~4	CRC Low	CRC High
1~32	0x03	0x04	0.0~300.0, 4 bytes stored in float point type	Calculated based on the first 7 bytes	

6.4.3.64 Address 65 (Output Current)

1) Command Description

This command is used to obtain the output current. The command is valid when the output is turned on.

2) Send Instruction Format

Instrument address	Function Code	High Address	Low Address	High bytes	Low bytes	CRC Low	CRC High
1~32	0x03	0x00	0x41	0x00	0x02	Calculated based on the first 6 bytes	

3) Return Instruction Format

Return instruction data range is 0.000~8.400A

Instrument address	Function Code	Number of Data	Data Byte 1~4	CRC Low	CRC High
1~32	0x03	0x04	0.000~8.400, 4 bytes stored in float point type	Calculated based on the first 7 bytes	

6.4.3.65 Address 66 (Output Power)

1) Command Description

This command is used to obtain the output power. The command is valid when the output is turned on.

2) Send Instruction Format

Instrument address	Function Code	High Address	Low Address	High bytes	Low bytes	CRC Low	CRC High
1~32	0x03	0x00	0x42	0x00	0x02	Calculated based on the first 6 bytes	

3) Return Instruction Format

Return instruction data range is 0.0~1000.

Instrument address	Function Code	Number of Data	Data Byte 1~4	CRC Low	CRC High
1~32	0x03	0x04	0.0~1000, 4 bytes stored in float point type	Calculated based on the first 7 bytes	

6.4.3.66 Address 67 (Output AP)

1) Command Description

This command is used to obtain the output AP. The command is valid when the output is turned on.

2) Send Instruction Format

Instrument address	Function Code	High Address	Low Address	High bytes	Low bytes	CRC Low	CRC High
1~32	0x03	0x00	0x43	0x00	0x02	Calculated based on the first 6 bytes	

3) Return Instruction Format

When the voltage mode is "AUTO" and the voltage is less than 150V, the return instruction data range is 0.0~33.6A; when the voltage mode is "AUTO" and the voltage is greater than 150V or the voltage mode is "HIGH", the return command data range is 0.0~ 16.8A.

Instrument address	Function Code	Number of Data	Data Byte 1~4	CRC Low	CRC High
1~32	0x03	0x04	0.0~16.8 or 0.0~33.6, 4 bytes stored in float point type	Calculated based on the first 7 bytes	

6.4.3.67 Address 68 (Output PF)

1) Command Description

This command is used to obtain the output power factor. The command is valid when the output is turned on.

2) Send Instruction Format

Instrument address	Function Code	High Address	Low Address	High bytes	Low bytes	CRC Low	CRC High
1~32	0x03	0x00	0x44	0x00	0x02	Calculated based on the first 6 bytes	

3) Return Instruction Format

Return instruction data range is 0.000~1.000.

Instrument address	Function Code	Number of Data	Data Byte 1~4	CRC Low	CRC High
1~32	0x03	0x04	0.000~1.000, 4 bytes stored in float point type	Calculated based on the first 7 bytes	

6.4.3.68 Address 69 (Output CF)

1) Command Description

This command is used to obtain the output CF. The command is valid when the output is turned on.

2) Send Instruction Format

Instrument address	Function Code	High Address	Low Address	High bytes	Low bytes	CRC Low	CRC High
1~32	0x03	0x00	0x45	0x00	0x02	Calculated based on the first 6 bytes	

3) Return Instruction Format

Return instruction data range is 0.000~1.000.

Instrument address	Function Code	Number of Data	Data Byte 1~4	CRC Low	CRC High
1~32	0x03	0x04	0.000~1.000, 4 bytes stored in float point type	Calculated based on the first 7 bytes	

Chapter 7 Technical Specifications

7.1 Product Specifications

7.1.1 AC Input

Model	TH7105	TH7110	TH7120
Phase	1 ϕ		
Voltage	115/230Vac \pm 15%		
Frequency	47~63Hz		
Maximum Current	16A/8A	30A/16A	30A
Power Factor	0.7		

Table 7-1 AC Input

7.1.2 AC Output

Rated Power	500W	1000W	2000W	
Output Power	0~300Vac			
Output Frequency	45.0Hz~500Hz			
Maximum current (RMS)	0~150Vac	4.2A	8.4A	16.8A
	0~300Vac	2.1A	4.2A	8.4A
Maximum current (AP)	0~150Vac	16.8A	33.6A	67.2A
	0~300Vac	8.4A	16.8A	33.6A
Phase	1 ϕ /2W			
THD	When output voltage 80~140V(low range) or 160~280V(high range) \leq 0.5%			
CF	\geq 4			
Linear adjustment rate	0.1% \pm 10%			
Load adjustment rate	\leq 0.5% (Resistive load)			
Response Time	<100uS			

Table 7-2 AC Output

7.1.3 Setup

Voltage	Range	0~300Vac
	Resolution	0.1V
Frequency	Range	45.0Hz~500Hz
	Resolution	0.1Hz(45.0Hz~99.9Hz); 1Hz(100Hz~500Hz)
ON/OFF PHASE	Range	0~359 $^{\circ}$

	Resolution	1°
--	------------	----

Table 7-3 Instrument Setup

7.1.4 Measurement

Model		TH7105	TH7110	TH7120	
Voltage	Range	0~300Vac			
	Resolution	0.1V			
	Accuracy	±(0.5% readings + 2 digits)			
Frequency	Range	45.0Hz~500Hz			
	Resolution	0.1Hz(45.0Hz~99.9Hz); 1Hz(100Hz~500Hz)			
	Accuracy	±0.1Hz			
Current	Range	0~150Vac	0.000~4.200A	0.000~8.400A	0.000~16.800A
		0~300Vac	0.000~2.100A	0.000~4.200A	0.000~8.400A
	Resolution	0.001A			
	Accuracy	±(0.5% readings + 3 digits)			
AP	Range	0~150Vac	0.00~16.80A	0.00~33.60A	0.00~67.20A
		0~300Vac	0.00~8.40A	0.00~16.80A	0.00~33.60A
	Resolution	0.01A			
	Accuracy	±(5% readings + 2 digits)			
Power	Range	0~500W	0~1000W	0~2000W	
	Resolution	0.1W(0~1000W)		0.1W(0~1000W); 1W(1000~2000W)	
	Accuracy	±(0.6% readings + 5digits) when PF>0.5			
PF	Resolution	0.001			
	Accuracy	Measure and display to 3 digits significant figures			

Table 7-4 Instrument Measurement

7.1.5 Convention

Memory Sequence	50 groups, 9 steps/group
Remote Signal Input	Output on, off, read manual mode memory sequence 1 to memory sequence 7
Remote Signal Output	Pass、Fail、Testing
Synchronous output signal	Output signal 10V、BNC type

Protection	Over-set current protection (HI-A), over voltage protection (OVP), low voltage protection (LVP), over current protection (OCP), over power protection (OPP), over temperature protection (OTP)
LCD Display	4.3 inch, 480×270
Interface	USB COM、RS232、USBHOST

Table 7-5 Convention

7.1.6 Dimension

Length (mm)	600		602
Width (mm)	430		430
Height (mm)	88		176
Net Weight (Kg)	30	40	75

Table 7-6 Dimension

7.2 Supplementary features

- Status memory capacity: 50 groups
- Operation status recommended calibration frequency: 1 time / year
- cooling method: fan

Chapter 8 Warranty

Warranty period: the warranty period is 1 year. During the warranty period, if the user damages the instrument due to improper operation of the user, the maintenance cost shall be borne by the user. The instrument is responsible for lifelong maintenance by Tonghui.

The maintenance of this instrument requires professional and technical personnel to carry out; please do not replace the internal components of the instrument without authorization; after the instrument is repaired, it needs to be re-calibrated to avoid affecting the test accuracy. Due to the blind maintenance of the user, the instrument damage caused by replacing the instrument parts is not covered by the warranty, and the user should bear the maintenance cost.

The instrument should be protected from sun and moisture and should be used correctly in the environment described in 1.2.2.

If the instrument is not used for a long time, the instrument should be sealed in the package offered Tonghui.

Chapter 9 Appendix

9.1 Error Message

- 1) <Measurement display> the status bar display “HI-A” indicates that the output current exceeds the set current high limit, the display “OVP” indicates that the output voltage exceeds the set voltage by 5V or 10V, the display “LVP” indicates that the output voltage is lower than the set voltage by 5V or 10V; the display "OCP" indicates that the output current exceeds the maximum value of the instrument current, the display "OPP" indicates that the output power exceeds the maximum value of the instrument power, and display "OTP" to indicate that the instrument temperature exceeds 130 °C.
- 2) “U disk is not found” means that the USB port on the front panel of the instrument is not inserted into the USB flash drive.

9.2 SCPI Commands

9.2.1 DISP Commands

Commands	Description
:DISP:PAGE:MEAS	Set the display page to the measurement display page
:DISP:PAGE:MANU:MEM	Set the display page to the sequence setting page in manual mode.
:DISP:PAGE:MANU:COMM	Set the display page to the common settings page in manual mode.
:DISP:PAGE:PROG:MEM1	Set the display page to the sequence setting page 1 in the programmed mode.
:DISP:PAGE:PROG:MEM2	Set the display page to the sequence setting page 2 in the programmed mode.
:DISP:PAGE:PROG:MEM3	Set the display page to the sequence setting page 3 in the programmed mode.
:DISP:PAGE:PROG:COMM	Set the display page to the common setting page in the programmed mode.
:DISP:PAGE:SYST:ENV	Set the display page to the system environment page under System Setting
:DISP:PAGE:SYST:COM	Set the display page to the system communication page under System Setting
:DISP:PAGE:SYST:TOOL	Set the display page to the system tool page under System Setting
:DISP:PAGE:INTF	Set the display page to the internal file page
:DISP:PAGE:EXTF	Set the display page to the external file page
:DISP:PAGE?	Query the current display page of the instrument

Table 9-1 DISP Commands List

9.2.2 FUNC Commands

Title	Commands	Description
Output Switch	:FUNC:OUTP 0	Turn on AC output
	:FUNC:OUTP 1	Turn off AC output
	:FUNC:OUTP?	Query current output state. Return 0 or 1
Test Mode	:FUNC:RM:MANU	Set the test mode as manual
	:FUNC:RM:PROG	Set the test mode as programmed control
	:FUNC:RM?	Query the current test mode. Return 0 or 1
Exit	:FUNC:EXIT	Exit result display status
Save	:FUNC:SR	Save the test results when the result display mode is ALL
Trigger	:FUNC:TRIG	Manually trigger a surge drop
MANU		
MEM	:FUNC:MEM:MANU <value>	Set the number of the memory sequence in manual mode
	:FUNC:MEM:MANU?	Query the number value of the memory sequence in manual mode
Voltage	:FUNC:VOLT:MANU <value>	Set the voltage value in manual mode
	:FUNC:VOLT:MANU?	Query the set voltage value in the current manual mode
V Mode	:FUNC:VOLT:MODE:MANU:AUTO	Set the voltage output in manual mode to AUTO mode
	:FUNC:VOLT:MODE:MANU:HIGH	Set the voltage output in manual mode to HIGH mode
	:FUNC:VOLT:MODE:MANU?	Query the voltage output mode in manual mode. Return 0 or 1
Frequency	:FUNC:FREQ:MANU <value>	Set the set frequency value in manual mode
	:FUNC:FREQ:MANU?	Query the set frequency value in manual mode
Current High Limit	:FUNC:CURR:HILMT:MANU <value>	Set the current high limit in manual mode
	:FUNC:CURR:HILMT:MANU?	Query the current high limit value in manual mode
Current Low Limit	:FUNC:CURR:LOLMT:MANU <value>	Set the current low limit value in manual mode
	:FUNC:CURR:LOLMT:MANU?	Query the current low limit value in manual mode
SD Voltage	:FUNC:SD:VOLT:MANU <value>	Set the voltage value of the surge drop in manual mode
	:FUNC:SD:VOLT:MANU?	Query the voltage value of the surge drop in manual mode
SD Site	:FUNC:SD:SITE:MANU <value>	Set the site where the surge drop appears in manual mode
	:FUNC:SD:SITE:MANU?	Query the site where the surge drop appears in manual mode
SD Time	:FUNC:SD:TIME:MANU	Set the time width of the surge drop in manual mode

	<value>	
	:FUNC:SD:TIME:MANU?	Query the time width of the surge drop in manual mode
SD Connectio n	:FUNC:SD:CT:MANU 0	Turn off SD connection in manual mode
	:FUNC:SD:CT:MANU 1	Turn on SD connection in manual mode
	:FUNC:SD:CT:MANU?	Query the SD connection status of the current memory sequence in manual mode. Return 0 or 1
V HiLmt	:FUNC:VOLT:HILMT:MANU <value>	Set the voltage high limit in manual mode
	:FUNC:VOLT:HILMT:MANU?	Query the voltage high limit in manual mode
V LoLmt	:FUNC:VOLT:LOLMT:MANU <value>	Set the voltage low limit in manual mode
	:FUNC:VOLT:LOLMT:MANU?	Query the voltage low limit in manual mode
F HiLmt	:FUNC:FREQ:HILMT:MANU <value>	Set the output frequency high limit value in manual mode
	:FUNC:FREQ:HILMT:MANU?	Query the output frequency high limit value in manual mode
F LoLmt	:FUNC:FREQ:LOLMT:MANU <value>	Set the output frequency low limit value in manual mode
	:FUNC:FREQ:LOLMT:MANU?	Query the output frequency low limit value in manual mode
ON PHS	:FUNC:SANG:MANU <value>	Set the ON phase in manual mode
	:FUNC:SANG:MANU?	Query the ON phase in manual mode
OFF PHS	:FUNC:EANG:MANU <value>	Set the OFF phase in manual mode
	:FUNC:EANG:MANU?	Query the OFF phase in manual mode
Test Result	:FUNC:RESULT:MANU 0	Set the result display mode to NONE in manual mode
	:FUNC:RESULT:MANU 1	Set the result display mode to LAST in manual mode
	:FUNC:RESULT:MANU 2	Set the result display mode to ALL in manual mode
	:FUNC:RESULT:MANU 3	Set the result display mode to P/F in manual mode
	:FUNC:RESULT:MANU?	Query the result display mode in manual mode. Return 0 or 1 or 2 or 3
Surge Drop	:FUNC:SD:MANU 0	Turn off the surge drop function in manual mode
	:FUNC:SD:MANU 1	Turn on the surge drop function in manual mode
	:FUNC:SD:MANU?	Query the state of the surge drop in manual mode
Over Current Fold	:FUNC:OCF:MANU 0	Turn off the over current fold function in manual mode
	:FUNC:OCF:MANU 1	Turn on the over current fold function in manual mode
	:FUNC:OCF:MANU?	Query the state of over current fold in manual mode
Voltage Restriction	:FUNC:VOLT:LMT <value>	Set output voltage limit protection in manual mode
	:FUNC:VOLT:LMT?	Query the voltage output limit value in manual mode
Timer seconds	:FUNC: TIME:SEC <value>	Set the second value of the timer in manual mode
	:FUNC: TIME:SEC?	Query the second value of the timer in manual mode
Timer	:FUNC:TIME:MIN <value>	Set the minute value of the timer in manual mode

minutes	:FUNC:TIME:MIN?	Query the minute value of the timer in manual mode
Timer	:FUNC:TIME:HOURL <value>	Set the hour value of the timer in manual mode
	:FUNC:TIME:HOURL?	Query the hour value of the timer in manual mode
PROG		
Memy	:FUNC:MEM:PROG <value>	Set the number of the memory sequence in the programmed mode
	:FUNC:MEM:PROG?	Query the number of the memory sequence in the programmed mode
Memy Cycle	:FUNC:MEM:CYCLE <value>	Set the loop cycle of the current memory sequence in the programmed mode
	:FUNC:MEM:CYCLE?	Query the loop cycle of the current memory sequence in the programmed mode
Step	:FUNC:STEP <value>	Set the number of the step of the current memory sequence in the programmed mode
	:FUNC:STEP?	Query the number of the step of the current memory sequence in the programmed mode
Step Cycle	:FUNC:STEP:CYCLE <value>	Set the loop cycle of the current step in the programmed mode
	:FUNC:STEP:CYCLE?	Query the loop cycle of the current step in the programmed mode
Voltage	:FUNC:VOLT:PROG <value>	Set the voltage of the current step in the programmed mode
	:FUNC:VOLT:PROG?	Query the voltage of the current step in the programmed mode
V. Mode	:FUNC:VOLT:MODE:PROG:AUTO	Set the voltage output in the programmed mode to AUTO
	:FUNC:VOLT:MODE:PROG:HIG H	Set the voltage output in the programmed mode to HIGH
	:FUNC:VOLT:MODE:PROG?	Query the voltage output mode in the programmed mode. Return 0 or 1
IRMS_H	:FUNC:CURR:HILMT:PROG <value>	Set the current high limit of the current step in the programmed mode
	:FUNC:CURR:HILMT:PROG?	Query the current high limit of the current step in the programmed mode
IRMS_L	:FUNC:CURR:LOLMT:PROG <value>	Set the current low limit of the current step in the programmed mode
	:FUNC:CURR:LOLMT:PROG?	Query the current low limit of the current step in the programmed mode
Frequency	:FUNC:FREQ:PROG <value>	Set the output frequency value of the current step in the programmed mode
	:FUNC:FREQ:PROG?	Query the output frequency value of the current step in the programmed mode
Connect	:FUNC:CONNECT 0	Turn off the step connection of the current step

	:FUNC:CONNECT 1	Turn on the step connection of the current step
	:FUNC:CONNECT?	Query the state of the step connection of the current step. Return 0 or 1.
AP HiLmt	:FUNC:AP:HILMT <value>	Set the power high limit of the current step in the programmed mode
	:FUNC:AP:HILMT?	Query the power high limit of the current step in the programmed mode
AP LoLmt	:FUNC:AP:LOLMT <value>	Set the power low limit of the current step in the programmed mode
	:FUNC:AP:LOLMT?	Query the power low limit of the current step in the programmed mode
P HiLmt	:FUNC:POW:HILMT <value>	Set the power high limit of the current step in the programmed mode
	:FUNC:POW:HILMT?	Query the power high limit of the current step in the programmed mode
P LoLmt	:FUNC:POW:LOLMT <value>	Set the power low limit of the current step in the programmed mode
	:FUNC:POW:LOLMT?	Query the power low limit of the current step in the programmed mode
PF HiLmt	:FUNC:PF:HILMT <value>	Set the power factor high limit of the current step in the programmed mode
	:FUNC:PF:HILMT?	Query the power factor high limit of the current step in the programmed mode
PF LoLmt	:FUNC:PF:LOLMT <value>	Set the power factor low limit of the current step in the programmed mode
	:FUNC:PF:LOLMT?	Query the power factor low limit of the current step in the programmed mode
Time Unit	:FUNC:TIME:UNIT:SEC	The time unit of delay judgement and test time in programmed mode is second
	:FUNC:TIME:UNIT:MIN	The time unit of delay judgement and test time in programmed mode is minute
	:FUNC:TIME:UNIT:HOURL	The time unit of delay judgement and test time in programmed mode is hour
	:FUNC:TIME:UNIT?	Query the time unit of the current step in the programmed mode. Return 0 or 1 or 2
Delay Time	:FUNC:DELAY <value>	Set the delay judgment time of the current step in the programmed mode
	:FUNC:DELAY?	Query the delay judgment time of the current step in the programmed mode
Dwell Time	:FUNC:DWELL <value>	Set the dwell time of the current step in the programmed mode
	:FUNC:DWELL?	Query the dwell time of the current step in the programmed mode

R_Up Time	:FUNC:RAMP:UP <value>	Set the ramp up time of the current step in the programmed mode
	:FUNC:RAMP:UP?	Query the ramp up time of the current step in the programmed mode
R_Dn Time	:FUNC:RAMP:DOWN <value>	Set the ramp down time of the current step in the programmed mode
	:FUNC:RAMP:DOWN?	Query the ramp down time of the current step in the programmed mode
SD Voltage	:FUNC:SD:VOLT:PROG <value>	Set the voltage of surge drop of the current step in the programmed mode
	:FUNC:SD:VOLT:PROG?	Query the voltage of surge drop of the current step in the programmed mode
SD Site	:FUNC:SD:SITE:PROG <value>	Set the site of surge drop of the current step in the programmed mode
	:FUNC:SD:SITE:PROG?	Query the site of surge drop of the current step in the programmed mode
SD Time	:FUNC:SD:TIME:PROG <value>	Set the time width of surge drop of the current step in the programmed mode
	:FUNC:SD:TIME:PROG?	Query the time width of surge drop of the current step in the programmed mode
SD Connect	:FUNC:SD:CT:PROG 0	Turn off the step connection of the memory sequence current step in program-controlled mode
	:FUNC:SD:CT:PROG 1	Turn on the step connection of the memory sequence current step in program-controlled mode
	:FUNC:SD:CT:PROG?	Query the connection status of the current step of the memory sequence in program-controlled mode. Return 0 or 1.
V HiLmt	:FUNC:VOLT:HILMT:PROG <value>	Set the voltage high limit of the current step in the programmed mode
	:FUNC:VOLT:HILMT:PROG?	Query the voltage high limit of the current step in the programmed mode
V LoLmt	:FUNC:VOLT:LOLMT:PROG <value>	Set the voltage low limit of the current step in the programmed mode
	:FUNC:VOLT:LOLMT:PROG?	Query the voltage low limit of the current step in the programmed mode
F HiLmt	:FUNC:FREQ:HILMT:PROG <value>	Set the output frequency high limit of the current step in the programmed mode
	:FUNC:FREQ:HILMT:PROG?	Query the output frequency high limit of the current step in the programmed mode
F LoLmt	:FUNC:FREQ:LOLMT:PROG <value>	Set the output frequency low limit of the current step in the programmed mode
	:FUNC:FREQ:LOLMT:PROG?	Query the output frequency low limit of the current step in the programmed mode

ON PHS	:FUNC:SANG:PROG <value>	Set the starting angle of the current step in the programmed mode
	:FUNC:SANG:PROG?	Query the starting angle of the current step in the programmed mode
OFF PHS	:FUNC:EANG:PROG <value>	Set the end angle of the current step in the programmed mode
	:FUNC:EANG:PROG?	Query the end angle of the current step in the programmed mode
Test Results	:FUNC:RESULT:PROG 0	Set the result display mode of the current step in the programmed mode to LAST
	:FUNC:RESULT:PROG 1	Set the result display mode of the current step in the programmed mode to ALL
	:FUNC:RESULT:PROG 2	Set the result display mode of the current step in the programmed mode to P/F
	:FUNC:RESULT:PROG?	Query the result display mode of the current step in the programmed mode. Return 0 or 1 or 2 or 3
Surge Drop	:FUNC:SD:PROG 0	Turn off the surge drop at the current step of the memory sequence in the programmed mode
	:FUNC:SD:PROG 1	Turn on the surge drop at the current step of the memory sequence in the programmed mode
	:FUNC:SD:PROG?	Query the state of surge drop at the current step of the memory sequence in the programmed mode. Return 0 or 1
Over Current Fold	:FUNC:OCF:PROG 0	Turn off the over current fold function at the current step of the memory sequence in the programmed mode
	:FUNC:OCF:PROG 1	Turn on the over current fold function at the current step of the memory sequence in the programmed mode
	:FUNC:OCF:PROG?	Query the over current fold state at the current step of the memory sequence in the programmed mode. Return 0 or 1
Loop Cycle	:FUNC:LC <value>	Set the loop cycle at the current step of the memory sequence in the programmed mode
	:FUNC:LC?	Query the loop cycle at the current step of the memory sequence in the programmed mode
Single Step	:FUNC:SS 0	Turn off the single step test function at the current step of the memory sequence in the programmed mode
	:FUNC:SS 1	Turn on the single step test function at the current step of the memory sequence in the programmed mode
	:FUNC:SS?	Query the state of single test step at the current step of the memory sequence in the programmed mode. Return 0 or 1

Table 9-2 FUNC Commands

9.2.3 SYST Commands

Title	Commands	Description
Pass Beep	:SYST:BEEP:PASS 0	Turn off the pass beep
	:SYST:BEEP:PASS 1	Turn on the pass beep
	:SYST:BEEP:PASS?	Query the state of pass beep
Fail Beep	:SYST:BEEP:FAIL 0	Turn off the fail beep
	:SYST:BEEP:FAIL 1	Turn on the fail beep
	:SYST:BEEP:FAIL?	Query the state of fail beep
Date	:SYST:DATE <date>	Set system date
	:SYST:DATE?	Query system date
Year	:SYST:DATE:YEAR <value>	Set the year of the system time
	:SYST:DATE:YEAR?	Query the year of the system time
Month	:SYST:DATE:MONTH <value>	Set the month of the system time
	:SYST:DATE:MONTH?	Query the month of the system time
Day	:SYST:DATE:DAY <value>	Set the day of the system time
	:SYST:DATE:DAY?	Query the day of the system time
Time	:SYST:TIME <time>	Set the system time
	:SYST:TIME?	Query the system time
Hour	:SYST:TIME:HOURL <value>	Set the hour of the system time
	:SYST:TIME:HOURL?	Query the hour of the system time
Minute	:SYST:TIME:MIN <value>	Set the minute of the system time
	:SYST:TIME:MIN?	Query the minute of the system time
Second	:SYST:TIME:SEC <value>	Set the second of the system time
	:SYST:TIME:SEC?	Query the second of the system time
PLC	:SYST:PLC 0	Turn off PLC
	:SYST:PLC 1	Turn on PLC
	:SYST:PLC?	Query the state of PLC
Last State	:SYST:LS 0	Do not keep the last power on state
	:SYST:LS 1	Keep the last power on state
	:SYST:LS?	Query whether to keep the state of the last power on
System Language	:SYST:LANG 0	Set the instrument interface to English
	:SYST:LANG 1	Set the instrument interface to Chinese
	:SYST:LANG?	Query the language used by the instrument
Internal File	:SYST:INTF:SAVE <name>	Save file to internal storage
	:SYST:INTF:LOAD <name>	Load internal stored files
	:SYST:INTF?	Query internally stored files

Table 9-3 SYST Commands

9.2.4 FETCH Commands

Commands	Description
:FETCH:VOLT?	Query the output voltage value in manual mode
:FETCH:CURR?	Query the output current value in manual mode
:FETCH:POW?	Query the output power value in manual mode
:FETCH:AP?	Query ampere peak value in manual mode
:FETCH:PF?	Query the power factor value in manual mode
:FETCH:CF?	Query crest factor value in manual mode
:FETCH?	Query measurement parameters such as voltage, current, power, ampere peak , power factor, and crest factor in manual mode

Table 9-4 FETCH Commands

9.3 MODBUS Commands

Address	Number of registers	Read/Write	Return Value	Command Description
1	1	Read	7105	Read the instrument model number. 7105 indicates that the instrument model is TH7105, 7110 indicates that the instrument model is TH7110, and 7120 indicates that the instrument model is TH7120.
			7110	
			7120	
2	1	Read/Write	0	Set or read the status of the output switch. 0 means the status of the instrument output is off; 1 means the status of the instrument output is on.
			1	
3	1	Read/Write	0	Set or read the test mode of the instrument. 0 means the instrument is in manual mode; 1 means the instrument is in programmed mode
			1	
4	1	Read/Write	1~50	Set or query the number of the memory sequence in manual mode
5	2	Read/Write	0~300	Set or query the set voltage in manual mode
6	1	Read/Write	0	Set or read the voltage mode in the instrument manual mode. 0 means the voltage output mode is AUTO; 1 means the voltage output mode is HIGH
			1	
7	2	Read/Write	45~500	Set or query the output frequency in manual mode

8	2	Read/Write	0~4.2or0~8.4	Set or query the current high limit in manual mode
9	2	Read/Write	0~4.2or0~8.4	Set or query the current low limit in manual mode
10	2	Read/Write	0~300	Set or query the voltage of the surge drop in manual mode
11	1	Read/Write	0~99or0~20	Set or query the site of the surge drop in manual mode
12	1	Read/Write	0~99or0~20	Set or query the time width of the surge drop in manual mode
13	1	Read/Write	0	Set or query the SD connection status of the surge drop in manual mode. 0 means the SD connection is off; 1 means the SD connection is on.
			1	
14	2	Read/Write	0~300	Set or query the high limit of the voltage in manual mode
15	2	Read/Write	0~300	Set or query the low limit of the voltage in manual mode
16	2	Read/Write	45~500	Set or query the high limit of frequency in manual mode
17	2	Read/Write	45~500	Set or query the low limit of frequency in manual mode
18	1	Read/Write	0~359	Set or query the starting angle in manual mode
19	1	Read/Write	0~359	Set or query the end angle in manual mode
20	1	Read/Write	0	Set or query the result display mode in manual mode. 0 means the result display mode is NONE in manual mode; 1 means the result display mode is LAST in manual mode; 2 means the result display mode is ALL in manual mode; 3 means the result display mode is P/F in manual mode
			1	
			2	
			3	
21	1	Read/Write	0	Set or query the status of the surge drop in manual mode. 0 means that the glitch trap is in the off state; 1 means that the surge drop is on.
			1	
22	1	Read/Write	0	Set or query the state of over current fold in manual mode. 0 means that the over current fold is always in the off state; 1 means that the over current fold is always on.
			1	
23	2	Read/Write	5~50	Set or query the allowable voltage difference between the set voltage and the output voltage in manual mode.
24	1	Read/Write	0~59	Set or query the seconds of timer in the manual mode
25	1	Read/Write	0~59	Set or query the minutes of timer in the manual mode
26	1	Read/Write	0~99	Set or query the hours of timer in the manual mode
27	1	Read/Write	1~50	Set or query the memory sequence number in the programmed mode

28	1	Read/Write	0~999	Set or query the sequence times in the programmed mode
29	1	Read/Write	1~9	Set or query the number of steps in the programmed mode
30	1	Read/Write	0~999	Set or query the number of steps of the current memory sequence in the programmed mode
31	2	Read/Write	0~300	Set or query the set voltage in the programmed mode
32	1	Read/Write	0	Set or read the voltage mode in the instrument programmed mode. 0 means the voltage output mode is AUTO; 1 means the voltage output mode is HIGH
			1	
33	2	Read/Write	0~4.2or0~8.4	Set or query the current high limit value in the programmed mode
34	2	Read/Write	0~4.2or0~8.4	Set or query the current low limit value in the programmed mode
35	2	Read/Write	45~500	Set or query the output frequency in the programmed mode
36	1	Read/Write	0	Set or query the step connection status of the current step in the programmed mode. 0 means the step connection is off; 1 means the step connection is on.
			1	
37	2	Read/Write	0~4.2or0~8.4	Set or query the ampere peak high limit value in the programmed mode
38	2	Read/Write	0~4.2or0~8.4	Set or query the ampere peak low limit value in the programmed mode
39	2	Read/Write	0~1000	Set or query the power high limit value in the programmed mode
40	2	Read/Write	0~1000	Set or query the power low limit value in the programmed mode
41	2	Read/Write	0~1	Set or query the power factor high limit value in the programmed mode
42	2	Read/Write	0~1	Set or query the power factor low limit value in the programmed mode
43	1	Read/Write	0	Set or query the time unit of the current step in the programmed mode. 0 means that the time unit of the current step is second; 1 means that the time unit of the current step is minute; 2 means that the time unit of the current step is hour
			1	
			2	
44	2	Read/Write	0.1~999.9	Set or query the delay judgement time of the current step in the programmed mode
45	2	Read/Write	0.1~999.9	Set or query the test time of the current step in the programmed mode
46	2	Read/Write	0.1~999.9	Set or query the ramp up time of the current step in the programmed mode

47	2	Read/Write	0.1~999.9	Set or query the ramp down time of the current step in the programmed mode
48	2	Read/Write	0~300	Set or query the voltage of the surge drop in the programmed mode
49	1	Read/Write	0~99or0~20	Set or query the position where the surge drop appears in the programmed mode.
50	1	Read/Write	0~99or0~20	Set or query the time width of the surge drop in the programmed mode
51	1	Read/Write	0	Set or query the SD connection status of the surge drop in the programmed mode. 0 means the SD connection is off; 1 means the SD connection is on.
			1	
52	2	Read/Write	0~300	Set or query the high limit of the voltage in the programmed mode
53	2	Read/Write	0~300	Set or query the low limit of the voltage in the programmed mode
54	2	Read/Write	45~500	Set or query the high limit of the frequency in the programmed mode
55	2	Read/Write	45~500	Set or query the low limit of the frequency in the programmed mode
56	1	Read/Write	0~359	Set or query the starting angle in the programmed mode
57	1	Read/Write	0~359	Set or query the end angle in the programmed mode
58	1	Read/Write	0	Set or query the result display mode in the programmed mode. 0 means the result display mode is LAST in the programmed mode; 1 means the result display mode is ALL in the programmed mode; 2 means the result display mode is P/F in the programmed mode.
			1	
			2	
59	1	Read/Write	0	Set or query the state of the surge drop in the programmed mode. 0 means that the surge drop is in the off state; 1 means that the surge drop is on
			1	
60	1	Read/Write	0	Set or query the state of over current fold in the programmed mode. 0 means that the over current fold is in the off state; 1 means that the over current fold is in the on state
			1	
61	1	Read/Write	0~999	Set or query the loop cycle of the memory sequence in the programmed mode
62	1	Read/Write	0	Set or query the status of the single-step test in the programmed mode. 0 means single step test is off; 1 means single step test is on
			1	
63	1	Write		The instruction is used to exit the result display state

64	2	Read	0~300	Read the measured voltage
65	2	Read	0~4.2or0~8.4	Read the measured current
66	2	Read	0~1000	Read the measured power
67	2	Read	0~4.2or0~8.4	Read the measured ampere peak
68	2	Read	0~1	Read the measured power factor
69	2	Read	0~1	Read the measured crest factor

Table 9-5 MODBUS Commands

9.4 Manual Amendment Description

V1.0.0-----2017.12

V1.0.1-----2017.12

- 1) Amend DISPLAY sub-system command figure 6-6, a colon is missing
- 2) Amend HIGH to HILMT, LOW to LOLMT, avoid misleading with voltage mode。
- 3) Chang Figure1-1

V1.0.2-----2018.03

- 1) Amend FUNCTION sub-system commandFigure6-7, image command error

V1.0.3-----2018.04

- 1) Amend Figure 3-9, add voltage limit parameters
- 2) Change Figure 3-10、3-11、3-12、3-13, Setup 1, 2 are wrong in the picture
- 3) Change Figure 5-5

V1.0.4-----2018.10

- 1) Add command :FUNCTION:VOLTLiMT。
- 2) Add MODBUS commands

V1.0.5-----2019.4

- 1) Amend command :FUNCTION:RESULT。
- 2) Amend Figure 6-7
- 3) Change the 5.5 result display function, add “NONE”
- 4) Add appendix SCPI commands and MODBUS commands
- 5) Amend MODBUS command format, organize MODBUS commands

V1.0.5-----2019.4

- 1) Change the figures to align with the instrument
- 2) Change MODBUS protocol instruction