



携手同心 惠及未来

OPERATION MANUAL

TH 6900 Series

Constant Power DC Power Supply

TH 6900 Series DC Power Supply

[V 1.1 @ 2022.06](#)



Table of Contents

Chapter 1	Overview	1
1.1	Introduction	1
1.2	Product Features	1
1.3	Safety Instructions	2
1.3.1	Safety Symbols.....	2
1.3.2	Safety Brief	3
1.4	Unpacking & Installation	5
1.4.1	Selected Installation Location.....	5
1.4.1.1	Inspection Before Unpacking	5
1.4.1.2	Unpacking	5
1.4.2	Environment.....	6
1.4.3	Input Wiring.....	7
1.4.4	Output Wiring.....	7
1.4.4.1	Wiring Instruction.....	7
1.4.4.2	Battery Load Wiring Instruction	8
1.4.4.3	Inductive Load Wiring Instruction.....	9
1.4.4.4	Wire Diameter Requirement.....	9
Chapter 2	Panel 1	2-1
2.1	Front Panel Description	1
2.1.1	Key Function Introduction.....	1
2.2	Rear Panel Description.....	3
2.3	Technical Specifications.....	3
2.3.1	Electrical Characteristics	3
2.3.2	Voltage & Current Specifications.....	5
2.3.3	Dimensions	5
Chapter 3	Operating Instructions 1SCPI Protocol 6-11	

Chapter 1 Overview

Thank you for purchasing and using our products. Before you use this instrument, please first confirm the matters in Chapter 7 of the manual "Warranty" to protect your rights and interests.

1.1 Introduction

TH6900 series constant power DC power supply (or DC power supply) is a DC type programmable power supply with exquisite appearance, small size, high performance, powerful function and simple operation. It is a high performance and wide range single output DC high power switching power supply for test systems in aerospace and defense, consumer electronics, computer and peripheral, communication, semiconductor, solar and automotive electronics industries.

The functional features of TH6900 series constant power DC power supply are as follows:

- High resolution and high accuracy;
- Low ripple and low noise;
- Wide voltage range, 0~1000V, various voltage levels available;
- Support multiple modes, power supply constant voltage (CV), constant current (CC), constant power (CP) mode;
- Fast transient response capability;
- Flexible operation interface for user-friendly operation;
- Output parallel connection is possible, and the modular design is convenient for users to expand capacity;
- Flexible and powerful sequence test function;
- Complete protection, safety performance is guaranteed;
- Support OVP, OCP, OPP and input undervoltage protection and over-temperature protection of the power supply;
- With analog control interface, the power output can be controlled separately through the external analog interface;
- Built-in USB/RS232/GPIB/LAN/CAN communication interface.

1.2 Product Features

TH6900 series constant power DC power supply is only 2U chassis, especially suitable for system testing and industrial control, the basic functions of the power supply are mainly:

- Constant voltage (CV) mode, constant current (CC) mode, constant power (CP) mode output

The output mode of the DC test power supply is divided into constant voltage (CV) mode, constant current (CC) mode and constant power (CP) mode. The output mode depends on the set value of the output voltage, and current as well as



the size of load resistance.













- Built-in input undervoltage, short circuit, over-temperature protection, internal hardware input undervoltage, short circuit, over-temperature protection, can stop the output in the shortest time to protect the DC test power supply and the load in the connection.
- POST Function
Every time the system is powered on, it must perform a self-test to check some of the internal circuits, and if it is not normal, it cannot enter the normal standby state interface.
- 10 non-volatile save and read back shortcut groups
To adapt to different test requirements, save 10 groups of operating modes, and store 10 groups of modes in non-volatile memory. They are not lost after power failure, and it can be easily recalled.
- Sequence test
The sequence test function contains a total of 50 sequences stored in non-volatile memory, each group contains 20 test steps, the user can edit the function of each step according to actual needs, so that the power supply can be output in constant voltage, constant current or constant power mode in a sequence to meet specific test requirements.
- Local or remote control operation mode
Switching the local operation mode, local mode can be operated by keystroke, and remote mode can only be operated by communication port. Please refer to the appendix for the specific commands of the protocol used for external communication.
- Analog port remote control operation mode
With a variety of voltage, current and overvoltage given mode, and complete control and monitoring functions.

1.3 Safety Instructions

The safety precautions in this section and in the manual must be followed throughout the operation, maintenance, and repair of this product. Failure to follow these safety precautions results in the manufacturer disclaiming that it is not responsible for the user's operations in violation of such requirements.

1.3.1 Safety Symbols







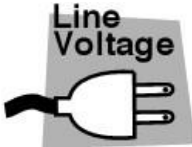

Symbol	Description	Symbol	Description
	Grounding		Turn on the power
			Disconnect the power

	PE	Protective Conductor		Indicates a switch that turns the power ON/OFF with the same operator. The normally used button has two stable positions.
	Prohibit			High temperature: indicates that the temperature here is higher than the acceptable range of the human body, do not arbitrarily contact to avoid injury to personnel.
	High Voltage Risk		 	This logo suggests that this device should not be mixed with other household waste for disposal. To prevent uncontrollable waste disposal from causing adverse ecological and health effects, the device should be recycled to improve the utilization of material resources. When recycling old devices, you can contact the retailer.
	Indoor Use			
	Safety: To avoid injury to personnel or damage to the instrument, the operator must refer to the instructions in the manual.			Danger! High Voltage
	The logo indicates that there is a risk that failure to follow the operating instructions may result in personal injury, so please do not operate without understanding the instructions.			This logo indicates that there is a risk that failure to follow operating instructions may result in injury or death, and this logo draws your attention to procedures, practices, conditions, etc.

1.3.2 Safety Brief

The following general safety precautions must be observed during operation or maintenance of this instrument, and we will not be liable for any injury to persons or damage to machinery caused by the customer's failure to observe these precautions or any of the specific warnings in this manual.

	<p>Please be sure to read this manual thoroughly before use and keep it in a safe place.</p>
---	--

	<p>Do not use the product for purposes other than those described in the manual.</p>
	<p>Before connecting the power supply, please check that the power supply meets the rated input value of the instrument, and make sure the switch is OFF.</p>
	<p>Protective grounding: Before turning on the power, be sure to connect the protective grounding to prevent electric shock.</p>
	<p>The need for protective grounding: Do not disconnect the internal or external protective ground wire or interrupt the connection of the protective ground terminal. Doing so will cause a potential electric shock hazard that may cause injury to humans.</p>
	<p>Fuses: Use only fuses of the required rated current, voltage and specific form (normal fuse, time delay, etc.). Do not use fuses of different specifications or short-circuit fuse holders, as this may cause a risk of electric shock or fire.</p>
	<p>Do not remove the housing of the instrument: The operator must not remove the housing of the instrument. Replacement of parts and internal adjustments should only be carried out by qualified service personnel.</p>
	<p>Do not operate in explosive or corrosive atmospheres Do not operate the instrument under flammable gas or gaseous or corrosive atmospheres</p>
	<ul style="list-style-type: none"> • Please turn off the power switch and disconnect all the wires when you change the position of the product. • The weight of the product is more than 20kg, please operate more than two people when resetting the position, you can find the weight of the product in the product manual. • Please be careful when handling the product, avoid collision, the high product is easy to fall, please be careful.
	<ul style="list-style-type: none"> • Check to make sure that the AC input voltage setting is consistent with the fuse specification and that there is no abnormality on the surface of the power cord, and make sure to disconnect the power cord or turn off the power switch before checking. • If there is any abnormality or fault, please stop using

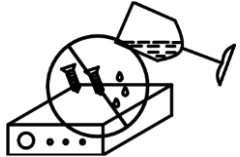
	<p>immediately, disconnect the power cord or disconnect the power from the power distribution box, and do not use until the product is repaired.</p> <ul style="list-style-type: none"> • Please use a cable with higher overcurrent capacity for output or load cable.
	<p>Do not allow water droplets or metal objects to enter the interior of this product.</p>



注意

If the product is damaged due to the use of incorrect grid input, it is not covered by the product warranty.



警告

When the voltage and current setting is completed and the output is started, the output terminal is a dangerous voltage, and touching it arbitrarily may cause injury or death.

1.4 Unpacking & Installation

1.4.1 Selected Installation Location

When installing, please choose a location with good ventilation and heat dissipation, the distance between the air inlet (outlet) and the wall or shelter should be more than 30cm, and avoid placing in the environment of direct sunlight, hot and humid, corrosive substances, and water shower is strictly prohibited.

1.4.1.1 Inspection Before Unpacking

Check the box for damage, and if damage is found, notify the freight forwarder to inspect the goods and record the damage at the time of delivery. If there is no damage, open the box according to the following steps.

1.4.1.2 Unpacking

- (1) Unpack the equipment according to the requirements of the outer box of the equipment and remove the equipment.
- (2) First check the product nameplate to make sure the model matches the order, check the objects in the box to make sure they match the packing list, if the items in the box do not match the contents listed in the "packing list", please contact the distributor or customer service center of Changzhou Tonghui Electronic Co.Ltd.
- (3) Visually observe whether there are obvious such as metal scratches damage, scribbles, dents, etc., check whether there is a loose connection, fasteners have not fallen off, or other abnormalities, if damage is found, please immediately

notify Changzhou Tonghui Electronics Co., Ltd. or its distributors. Our customer service center will repair or replace the machine for you. Please do not return the product immediately without notifying Changzhou Tonghui Electronics Co., Ltd. or its dealers.

- (4) To prevent accidental electric shock, please do not open the top cover of the instrument by yourself. If any abnormality happens to the instrument, please seek technical support from Changzhou Tonghui Electronics Co.,Ltd. or its designated distributors.

1.4.2 Environment

- (1) Power supply in the installation should maintain good ventilation and heat dissipation, power supply inlet (outlet) and the distance between the wall or shelter should be more than 30cm, and contact with corrosive substances is strictly prohibited.
- (2) Please make sure that the AC power to be connected meets the specifications.
- (3) Please refer to the specification parameters of each model for ambient temperature and humidity.
- (4) After the power supply is installed and test run, it is recommended that the power supply should be left in an energized state so that it can provide the best operating conditions for the electronic components and can keep some of the important components from getting wet. If the power supply has not been used for a long time, it should be visually inspected first, and if moisture is found in any internal location, this part must be made dry before use. General environmental conditions:
 - Not for outdoor use.
 - Keep away from flammable and explosive corrosive media: such as alcohol, diluent, sulfuric acid and other flammable and explosive corrosive materials.
 - Keep away from heat sources and avoid exposure to the sun.
 - Operating environment temperature: 0°C ~+50°C
 - Storage environment temperature: -25°C ~+65°C
 - Keep away from boilers, humidifiers, water sources, etc.
 - Working relative humidity: 10~95%RH, no condensation.
 - Storage relative humidity: not more than 80% (storage in high humidity environments, it is recommended to run the machine regularly for 20 minutes to avoid condensation of water vapor).
 - Keep away from strong electromagnetic interference sources and significant vibration and shock.
 - The working environment must be well ventilated and free of dust. Please keep the area around the vent open

within 30cm and without any sundries.

- Rapid changes in temperature must be avoided. Rapid changes in temperature can cause water vapor to condense inside the machine. When water vapor condensation occurs, the use of this power supply is prohibited.
- The input AC supply voltage fluctuates by $\pm 10\%$ of the rated voltage.
- The product should not be placed in a restricted location where the plug cannot be easily removed or the input switch cannot be easily disconnected to prevent a dangerous situation where the input cannot be disconnected.

1.4.3 Input Wiring

The connection between the power supply and the mains needs to use the attached power cord. If you need to use a different AC line, please ensure that the cross-section of the line is at least 2.5mm^2 . The default input value of this series is $220\text{V}\pm 10\text{V}$, 16A, 50Hz.



Please make sure the input power is disconnected before wiring. Due to the existence of leakage current, it can lead to the enclosure being charged, the grounding terminal should be well grounded to protect the safety of personnel.



The DC power input requires the connection of a circuit breaker or fuse with a current rating of 1.25 times the maximum input current of the power supply.

1.4.4 Output Wiring

1.4.4.1 Wiring Instructions

- (1) Connection method when lead voltage drop compensation function is not used

Connect the output terminals to the load as shown in Figure 2-1(a), and use the short route to connect the positive output terminal to S+ and the negative output terminal to S-. At this time, no compensation of lead voltage drop is performed, and the voltage value displayed is the voltage at the output of the power supply, not the voltage at both ends of the load.

- (2) Connection method when using the lead voltage drop compensation function

Connect the output terminals to the load as shown in Figure 2-1(b), with the positive output and S+ connected to one end of the load at the same time, and the negative output and S- connected to the other end of the load at the same time, at this time the displayed voltage value is the actual voltage at both ends of the load, realizing the function of lead voltage drop compensation.

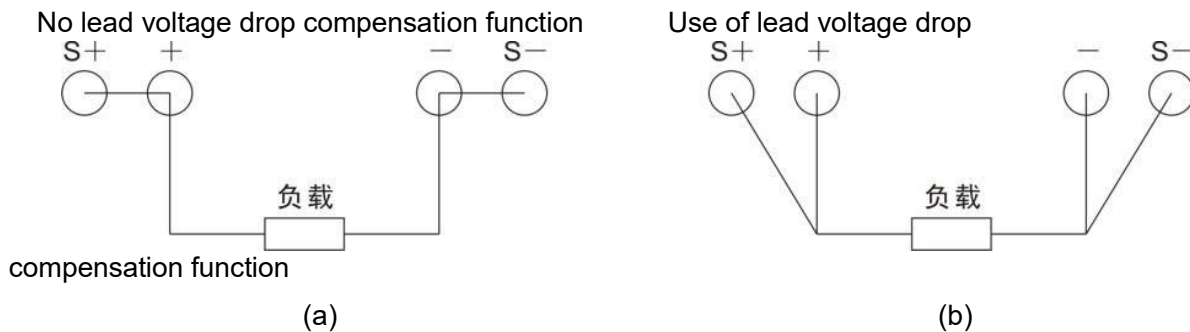

Figure 1-1 Output Wiring

⚡ 注意 If the output terminals of the power supply are not wired to the load, but only the SENSE line is connected, the current flows from the SENSE line and can damage the internal devices of the power supply.

1.4.4.2 Battery Load Wiring Instructions

The TH6900 series constant power DC power supply can be applied to battery type loads and must be operated in accordance with the following precautions in the process of use.

- (1) Must be wired in accordance with Figure 1-2:

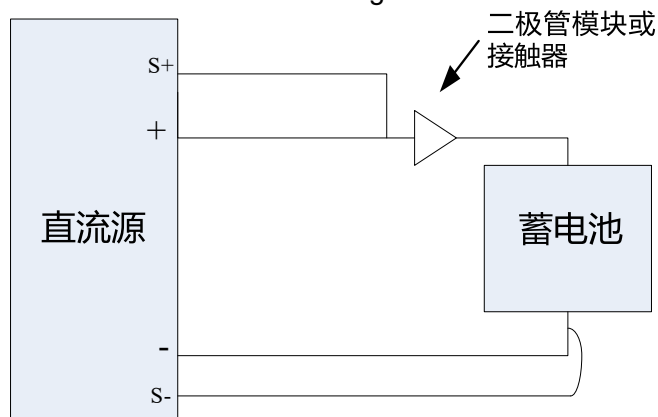

Figure 1-2 Battery Load Wiring Mode

- (2) Connect a diode or DC contactor (diode module is recommended) in series between the DC power supply and the load (battery). Avoid causing damage to the DC power supply and the battery.
- (3) The diode is selected according to the following principles: the minimum reverse withstand voltage value is 2~3 times the output voltage of the DC test power supply; the minimum

forward conduction current is 1.5 times the maximum output current of the DC source.

(4) Operation with contactors

First, when connecting the DC test power supply to the load, the contactor must be disconnected; second, after the DC test power supply is turned on and the output is activated, the contactor is closed;

Finally, when stopping charging, the contactor must be disconnected before stopping the DC test power output.

1.4.4.3 Inductive Load Wiring Instructions

The TH6900 series constant power DC power supply can be applied to inductive loads and must be operated in accordance with the following precautions during use.

(1) Must be wired as shown in Figure 1-3:

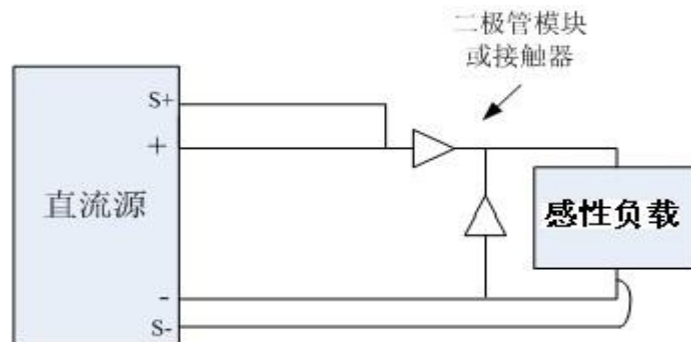

Figure 1-3 Inductive Load Wiring Mode

- (2) Connect diodes or DC contactors (diode modules are recommended) in parallel or series between each DC power supply and the load (inductive). Avoid causing damage to the DC power supply and the load.
- (3) The diode is selected according to the following principles: the minimum reverse withstand voltage value is 2~3 times the output voltage of the DC test power supply; the minimum forward conduction current is 1.5 times the maximum output current of the DC source.

1.4.4.4 Wire Diameter Requirements

Current	Input Lead Wire Diameter (including ground wire)	Output Lead Wire Diameter
10A	BVR 2.5mm ²	BVR 2mm ²
15A		BVR 2mm ²
20A		BVR 2.5mm ²
30A		BVR 6mm ²
60A		BVR 16mm ²
120A		BVR 50mm ²

Table 1-1 Output Lead Wire Diameter



注意

- 1) Please do not use the wire that is too thin in diameter to avoid overheating of the connection wire, which may cause danger.
- 2) The ground wire is recommended to use copper braid with a single wire diameter of not more than 0.15mm.

Chapter 2 Panel Description

The content of this chapter is only a general description, the specific operations and detailed explanation refer to the corresponding content of Chapter 3.

2.1 Front Panel Description

The front panel of TH6900 system power supply 2U model is the same, and the front panel of other models is the same as the front panel of 2U model. The following schematic diagram is the front panel schematic diagram and key function diagram of 2U model.

The schematic diagram of the front panel is shown in Figure 2-1.



Index	Features	Index	Features
1	Power switch button	5	Turn the button to adjust the voltage and current output value
2	Liquid Crystal Display	6	Start, stop output buttons and function buttons
3	Functional soft keyboard	7	Number keys and Escape key
4	Status indicator		

2.1.1 Key Function Introduction

The front panel keypad area is shown in the figure above. The keys set and control the output voltage and current, and provide the output status display through the LCD screen, with specific function descriptions:

Key Name	Function Description
F1-F4	The 4 buttons have different functions in different interfaces for user convenience.
Rotate button	In the setup interface, the CURRENT knob is used to adjust the cursor position, and the VOLTAGE knob is used to modify the value of the parameter corresponding to the cursor; in the power-on output state, the VOLTAGE knob is used to modify the voltage output value, and the CURRENT knob is used to modify the current output value.

Start/Stop key	Start or stop setting voltage and current output
VOLT	Voltage setting key, set the power output voltage value
CURR	Current setting key, set the power output current value
POWER	Power value setting, used to set the power supply output power
MENU	used to access the main menu
▲/▼	Up and down keys, used to select menu items in menu operations
CANCEL	Return key, return to the previous menu, set parameters invalid
0~9 number keys	Numeric input keys
ENTER	Confirmation key to confirm the entered number and operation

- (1) LED indicators: 4 indicators, when lit, indicate entry into the corresponding state.
- (2) CV: The light is on to indicate that it is in constant voltage output mode.
- (3) CC: The light is on to indicate that it is in constant current output mode.
- (4) CP: The light is on to indicate that it is in constant power output mode.
- (5) REMOTE: The light is on to indicate that the remote mode is entered.



When the switch is closed, it does not cut off the external input voltage, there is still high voltage inside the chassis, users should not open the case by themselves, customer service personnel for maintenance, should first remove the input cable.



Menu, **VOLT**, **CURR**, **POWER** do not respond in the sequence test execution, pause, single-step execution, and constant power mode execution screens.

2.2 Rear Panel Description

The rear panel of TH6900 system power supply 2U model is the same, and the rear panel of other models is the same as that of 2U model. Figure 2-2 is the rear panel schematic of the 2U model.

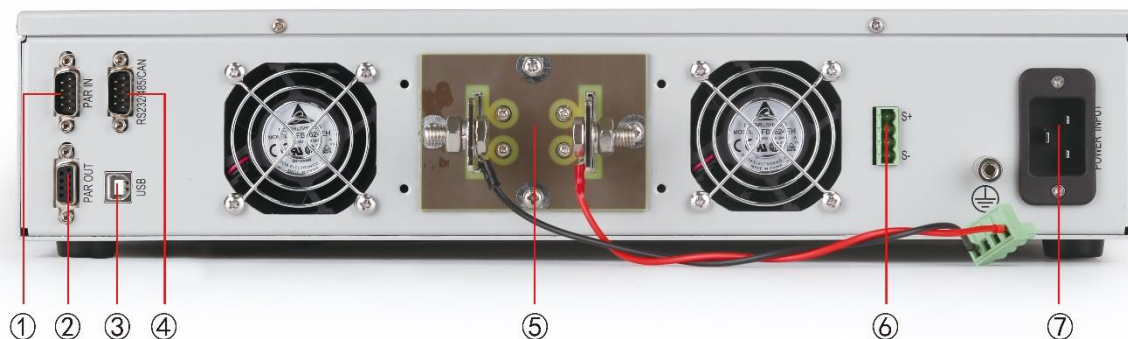

Figure 2-2 Rear Panel Schematic

Index	Features	Index	Features
1	Parallel input interface: as a slave	5	Power output terminal
2	Parallel output interface: as a host	6	Remote S compensation terminal
3	USB interface	7	Power input terminal
4	RS232/RS485/CAN/remote analog control interface		

Optional: Analog control interface, through which external analog signals control the output of the power supply, including voltage, current, OVP settings, start/stop, output and status monitoring.

2.3 technical specifications

TH6900 series constant power DC test power supply contains three basic models, 750W, 1.5KW and 3KW, with output voltage from 0~40V to 0~1000V and output current from 0~2.5A to 0~120A, corresponding to different models. Regardless of manual control or remote control (analog or digital), voltage, current and power can be continuously adjusted between 0% and 100%.

2.3.1 Electrical Characteristics

AC input voltage	
Voltage	90~264V, 1ph+N (model 1500W) 180~264V, 1ph+N (model 3000W)
Frequency	45~66Hz
Power Factor	≥0.99

Power Derating	Model 1500W: <math><150V_{AC}</math> reduced to 1000W Model 3000W: <math><205V_{AC}</math> reduced to 2500W
DC Output Voltage	
Accuracy \pm (%of output+offset)	$\leq \pm(0.05\%+0.04\%FS)$
0-100% Load Regulation	$\leq 0.05\%$ of full scale
$\pm 10\% \Delta U_{AC}$ Linear Adjustment Rate	$\leq 0.02\%$ of full scale
Load 10-100% adjustment time required	$\leq 2ms$
Output Voltage Rise Time	Maximum 30ms (10~90% full scale)
Overvoltage Protection	Adjustable, the range is 0~110%
DC Output Current	
Accuracy \pm (%of output+offset)	$\leq \pm(0.15\%+0.1\%FS)$
0-100% ΔU_{DC} Load Regulation	$\leq 0.15\%$ of full scale
$\pm 10\% \Delta U_{AC}$ Linear Adjustment Rate	$\leq 0.05\%$ of full scale
DC Output Power	
Accuracy	$\leq 0.8\%$ of full scale
Protective Function	OTP,OVP,OCP,OPP,PF
Isolation Withstand Voltage	
AC input to housing	2500V _{DC}
AC input to DC output	2500V _{DC}
DC output to housing (PE)	Negative pole: 400V _{DC} max, Positive pole: 400V _{DC} max + output voltage
Analog Interface:	Built-in 15-pin D-Sub female connector, electrical isolation
Signal Range	0~5V or 0~10V (switchable)
U / I / P / R Accuracy	0~10V: $\leq 0.2\%$ 0~5V: $\leq 0.4\%$
Communication Interface	RS232/RS485/CAN/GPIB/USB/LAN and other communication interfaces
Parallel Operation	Achievable, with true master-slave operation, to connect up to 10 products (via shared bus)

Cooling Mode	Temperature controlled fan
Operating Temperature	0~50°C
Storage Temperature	-20~70°C
Humidity	<80%, no condensation
Operational Height	<2000m

2.3.2 Voltage & Current Specifications

Voltage	Power			Efficiency	Ripple and Noise	
	750W	1.5KW	3KW		RMS (20Hz-300KHz)	PP (20Hz-20MHz)
	Current					
40	60	60	120	≤92%	20mVrms	75mVpp
80	30	60	120	≤92%	20mVrms	100mVpp
200	12.5	30	60	≤92%	25mVrms	175mVpp
360	7.5	15	30	≤93%	30mVrms	250mVpp
500	5	10	20	≤93%	45mVrms	325mVpp
750	3	7.5	15	≤93%	75mVrms	500mVpp
1000	2.5	5	10	≤93%	100mVrms	650mVpp

* VPP measurement requires a 1uF capacitor connected to the output terminal with a lead length of 1.8m, full load, and standard input voltage.

* VRMS measurements are taken directly at the output terminal, at full load, with standard input voltage.

2.3.3 Dimensions

Physical Parameters	2U Model
Width	482mm
Length	455mm
Height	88mm

Weight	13.5Kg
--------	--------



Figure 2 -3 Dimensions

Chapter 3 Operating Instructions

3.1 Introduction

This chapter will describe in detail how to use the front panel of the power supply to achieve the power supply function and operation of the power supply, the preparation and inspection of the power supply before use:

- (1) Make sure that the power cable and input and output cables are properly connected.
- (2) Please read the safety and warning signs posted on the instrument itself carefully before use.

3.2 Display Frame Description

3.2.1 Startup Picture

After checking the power cord to make sure it is correct, turn on the power switch. The welcome interface is shown in Figure 3-1 after power on.



Figure 3-1 Boot Screen

Under normal condition, it enters the standby interface about 5-10S, otherwise the power supply will enter the corresponding alarm state according to the error detected by self-test.

After the self-test is completed, the standby interface is entered, as shown in Figure 3-2:

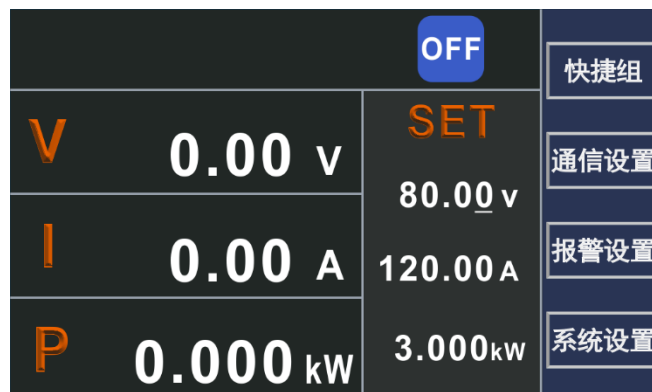

Figure 3-2 Standby Interface

3.2.2 Start & Stop

Press the **ON/OFF** button, if the start is successful, the red indicator inside the **ON/OFF** button lights up, indicating that it is in the output working state, while the indicator shows that it is currently in the CV, CP or CC state, as shown in Figure 3-3.

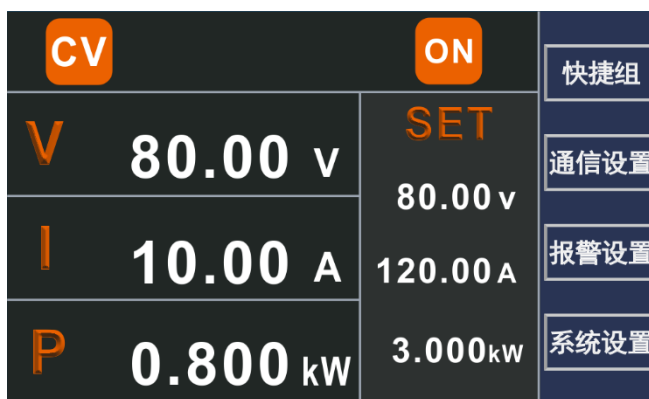

Figure 3 -3 Boot Screen

In the start state, press the **ON/OFF** button to stop the output and the output indicator goes out.

3.2.3 Set Output Voltage, Current and Power Values

In the standby interface, press the **VOLT** or **CURR** or **POWER** button to change the setting parameters directly. A white line will be prompted below the selected parameter, press the numeric keys or use the knob to modify the selected value, as shown in Figure 3-4 .

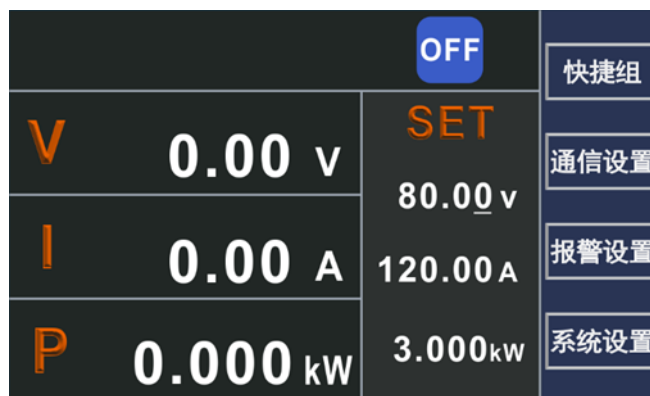

Figure 3-4 Setup Mode

3.2.4 Basic Setup

Under the comprehensive setting interface, you can mainly set the machine's LCD screen brightness, key sounds, language switching, keyboard lock, and view the machine system information. In the standby interface, press **F4** to enter the comprehensive setting interface, as shown in Figure 3-5 . Use

the knob to adjust the brightness, press **F1** to save, or **F4** to cancel saving to enter the standby interface; in the keyboard lock state only respond to key **F4**, press **F4** to enter the standby interface; use the knob to select information query, press **F3** to display the machine model, the last calibration date and software version and other information.

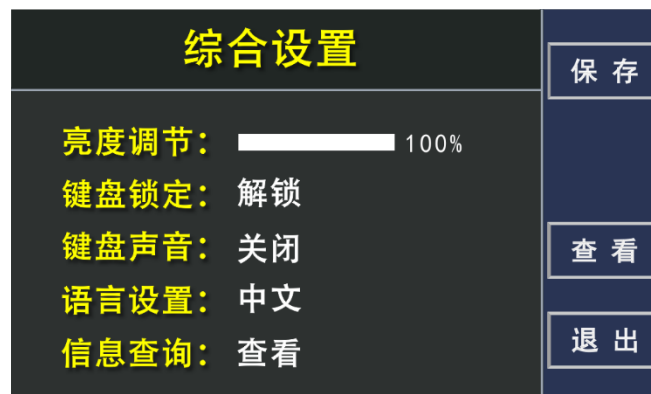

Figure 3-5 Comprehensive Setting Interface

3.2.5 Communication Setup

Press **F2** in the standby interface to enter the communication setting interface, as shown in Figure 3-6, the communication interface can be set as RS232/485/LAN/USB/CAN, select the item to be set by **↑**, **↓**, and use the knob to set the value of the parameter. Please refer to the appendix for specific communication commands, the address range is 1-255.



Figure 3-6 Communication Interface Setting

Press the **LOCAL** button to switch to the local mode. The remote operation mode here is communication control, and does not include the analog port control mode. When controlled through a communication interface such as RS232, the power supply automatically enters the remote mode, which will not respond to key functions.

注意 When using remote operation, the power supply and the computer must be grounded at the same time and hot-plugging is prohibited to avoid damage to the power supply or the computer.

3.2.6 Alarm Setup

The machine will send out alarms by signals for a variety of conditions, all alarm conditions will be displayed on the LCD screen, and there are alarm sound prompts, according to the different types of alarms machine, the alarm conditions can be divided into hardware alarms and software alarms, hardware alarm conditions include power failure alarm, over-temperature alarm, overload alarm, software alarm conditions include voltage, current, power upper and lower limit alarm, and master-slave protection alarm. The settings of software alarm are shown in Figure 3-7.



Figure 3-7 Alarm Setting Interface

Alarm	Meaning	Description
PF	Electric Failure	AC supply over- or under-voltage, power supply over specification or power failure will generate an alarm and the DC output will turn off.
BUCK	Hardware Failure	A failure in the hardware supply circuit will generate an alarm and the DC output will turn off.
OT	Overtemperature Alarm	The product's internal temperature exceeding a certain limit will trigger a sub-alarm and the DC output will turn off.
MSP	Master-slave Protection	Disconnection of the master from any slave under an initialized master-slave system triggers this alarm, and the DC output is turned off.
OVP	Voltage Upper Limit Alarm	If the voltage at the DC output terminal exceeds the set voltage upper limit, this alarm will be triggered and the DC output will be turned off.
OCP	Current Upper Limit Alarm	If the current at the DC output terminal exceeds the set current upper limit, this alarm will be triggered and the DC output will be turned off.
OPP	Power Upper Limit Alarm	If the power of the DC output terminal exceeds the set power upper limit, this alarm will be triggered and the DC output will be turned off.

UVP	Voltage Limit Alarm	Lower	If the voltage at the DC output terminal is lower than the set voltage lower limit, this alarm will be triggered and the DC output will be turned off.
UCP	Current Limit Alarm	Lower	If the current at the DC output terminal is lower than the set current lower limit, this alarm will be triggered and the DC output will be turned off.
UPP	Power Limit Alarm	Lower	If the power of the DC output terminal is lower than the set power lower limit, this alarm will be triggered and the DC output will be turned off.

**注意**

When the machine is turned off by the power switch, it cannot be distinguished from the power failure of the power supply terminal, so each time the machine is turned off, it will be prompted with PF alarm, which can be ignored at this time.

3.2.7 System Setup

Press **F4** in the standby interface to enter the system setting interface, as shown in Figure 3-8. The following functions can be selected by knob or numeric keys in the system setting interface.

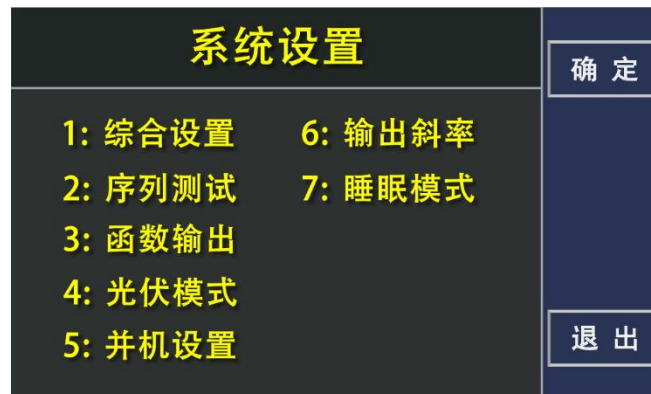



Figure 3-8 System Setting Interface

3.2.8 Shortcut Group Save and Recall

In the standby interface, according to the interface prompts, press **F1** to enter the shortcut group interface, and then press **F1** to enter the shortcut group editing interface as shown in Figure 3-9 to set and save the shortcut group parameters.

快捷组				保存
→ 0	0.00 V	0.00 A	0.000 kW	退出
1	0.00 V	0.00 A	0.000 kW	
2	0.00 V	0.00 A	0.000 kW	
3	0.00 V	0.00 A	0.000 kW	
4	0.00 V	0.00 A	0.000 kW	

Figure 3-9 Shortcut Group Interface

The VOLT voltage value, CURR current value, and POWER power value are selected by the knob or ,  buttons. A white line will be indicated below the selected parameter, press the numeric keys or use the knob to modify the selected value.

When the modification is completed, press the  button to save the shortcut group and return to the shortcut group interface as shown in the figure above.







注意

Group 0 parameters are read as default values after the power is turned on.

In the standby interface, according to the interface prompt, press  to enter the shortcut group recall interface to query and recall the parameters in the shortcut group, as shown in Figure 3-10.

快捷组				编辑
→ 0	0.00 V	0.00 A	0.000 kW	调用
1	0.00 V	0.00 A	0.000 kW	
2	0.00 V	0.00 A	0.000 kW	
3	0.00 V	0.00 A	0.000 kW	
4	0.00 V	0.00 A	0.000 kW	

Figure 3-10 Parameter Recall Interface

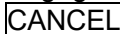
Browse the parameters of groups 0-9 by  and  buttons, press  to select the corresponding group in the shortcut group recall interface, press  or  to abandon the recall and return to the standby interface.

3.2.9 Sequence Test

Sequence test function allows users to set a series of voltage, current, power, and automatically output with the set rules to better meet the user's application of automatic testing and aging,

etc. A total of 50 sequences can be stored, each sequence contains 22 steps, each step of the function can be set independently, a total of 12 independent functions, including cycle control, ramp mode output and other rich control functions.

3.2.9.1 Basic Operation of Sequence Test

In the standby interface, press **F2** to enter the main sequence test interface, as shown in Figure 3-11.



Figure 3-11 Sequence Test Main Interface

In this screen, you can select one of the 50 sequences by using the numeric keys or the knob. The name of the sequence is in the format XX, where XX stands for 00-49.

From the main sequence test screen, you can start **(F1)** a sequence test, run it in a single-step **(F2)**, edit the sequence **(F3)** and delete the sequence **(F4)**.



注意

If operating sequence test related content via RS232, do not use communication commands that are not related to sequence test, see Appendix A/B for details of communication commands. If you are not operating the sequence test section, do not use sequence test related commands.

 **注意** When using the sequence test, avoid frequent voltage switching, if this can lead to damage to the internal devices of the power supply.

The following principles should be followed when using:

1. Pre-estimate the frequency of the desired sequence and the peak-to-peak value of the voltage (VPP).
2. Then estimate the percentage of the total voltage output accounted for by VPP, i.e., the %VPP. If the VPP of the design sequence is 10V and the maximum voltage of the power supply is 100V, then it is noted as %VPP=10/100=10%.
3. The relationship between frequency and VPP percentage should not exceed the table below.

Frequency	%VPP
10HZ	25%
50HZ	5.0%
100HZ	2.5%
150HZ	1.67%
200HZ	1.25%

4. When setting the running time of each step, you also need to consider the actual output rise or fall time. If it is not set properly, it will not create danger but the output waveform may be very different from what is needed, and this time has a lot to do with the actual load conditions. If you want to know more about it, please contact the manufacturer.

3.2.9.2 Launch Sequence Test

In the main interface of sequence test, press **F1** to start the sequence test and enter the sequence test execution interface as shown in Figure 3-12 to start executing a sequence.



Figure 3-12 Sequence Test Execution Interface

The interface displays the current running sequence number and step (e.g.: SEQ00:00, indicating step 0 of sequence 0), the function of the current step (e.g. Ramp V), the voltage, current, power and remaining execution time of the current step, and the time is in the format of ss.sss (the last 3 bits indicate milliseconds)

During the sequence test execution, press **F1** to pause the test or **F2** to stop the test, at this time the output will keep the output value of the current step. When stopping the test, return to the main sequence test interface. In the pause state, press **F1** to continue the test.



注意

When the sequence test is executed, the output of the power supply is still controlled by the ON/OFF key, that is, after the sequence test is started, the output needs to be started by pressing ON/OFF, and after the sequence test is paused or stopped, the output is stopped by pressing ON/OFF.

3.2.9.3 Sequence Test Single-step Run

In the main interface of sequence test, press **F2** to start single-step operation and enter the sequence test single-step execution interface as shown in Figure 3-13 to start a sequence in a single-step.



Figure 3-13 Sequence Test Single-step Run Interface

The interface shows the sequence number and step of the current run, the function of the current step, the voltage, current, power and remaining execution time of the current step.

When the current step is complete, press **F1** to continue with the next step. **F2** stops the test and returns to the main sequence test screen.

3.2.9.4 Sequence Parameter Editing

In the main interface of sequence test, press **F3** to enter the sequence program editing interface. It displays the sequence number and step of current edit, the function of the current step and the corresponding parameters, a total of 13 functions, which will be introduced one by one below.

The editing screen menu includes:

Copy (**F1**): Copy the parameters of the current step into the buffer.

Paste (**F2**): Paste the parameters copied into the buffer to the current step.

Insert (**F3**): Insert a step before the current step and move the following steps backward in order.

Delete (F4): Delete the current step.

Enter the sequence test editing interface, the function selection position is reversed, use the knob to select any one of the 13 functions, after selecting the function, select the parameter to be edited by the \uparrow and \downarrow keys, the numeric keys or use the knob to set the value of the parameter. The main process of sequence editing is as follows:

(1) After setting the function of the current step, select the parameter to be edited and set the parameter value.

(2) After editing a step, locate the editing position on the step number at the top of the screen and select the next step to be edited.

(3) Repeat step 1.

(4) After editing, press CANCEL to enter the sequence parameter saving interface, as shown in Figure 3-14. Press F1 to save the parameters and return to the main sequence test interface, press F4 to cancel saving and return to the main sequence test interface, or press CANCEL to return to the sequence parameter editing interface.



Figure 3-14 Sequence Parameter Saving

The following is a detailed description of each function:

NOP - Null Operation, unused steps should be set to this mode and skipped directly in the sequence test with no effect on the xoutput and settings, as shown in Figure 3-15 .



Figure 3-15 NOP Function

VI Mode - Voltage/current mode, this mode requires setting the

voltage, current, power value and duration to output at the set voltage, current, power and duration, as shown in Figure 3-16.



Figure 3-16 VI Mode

Ramp V - Voltage ramp mode, i.e., the output voltage gradually reaches the set end value (V_f) from the initial value (V_i) in a slope within the set time. During execution, the power supply automatically calculates an appropriate slope control function internally to drive the power supply output based on V_i , V_f and the set time, selecting V_i , V_f , current limit and duration by \uparrow and \downarrow keys, using the numeric keys or the knob to adjust the values of the parameters as shown in Figure 3-17.



Figure 3-17 Voltage Slope Mode

Ramp I - Current slope mode, i.e., the output current gradually reaches the set end value (I_f) from the initial value (I_i) in a slope within the set time. I_i , I_f , voltage limit and duration are selected by \uparrow and \downarrow , and the value of the parameters are adjusted by the numeric keys or using the knob, as shown in Figure 3-18.



Figure 3-18 Current Slope Mode

Repeat - Return to the starting position of the sequence (the starting position here may be the beginning of the current sequence or the beginning of another sequences, depending on the number of branches in the sequence execution and the use of the SubCall function) to execute the previous steps of Repeat once again, and when Repeat is encountered again, it will be skipped and the next steps will be executed. If you want the number of repetitions to be greater than 1, please use the Loop function. This function does not require parameters as shown in Figure 3-19.



Figure 3-19 Repeat Function

Subcall - This command allows calling other sequences to run as a subsequence during the sequence test execution, and If the subsequence contains the Return command, it returns to the main sequence to continue executing the subsequent steps of the Subcall command, as shown in Figure 3-20.



Figure 3-20 Subsequence Call Function

Return - This command allows the execution of a sequence test to return immediately to the sequence in which the Subcall command was last invoked during the execution of the sequence test. If no Subcall call has occurred by the time the Return command is executed, the sequence test stops and returns to the main sequence test interface. This command is often used in the last step of the sequence to return to the main calling sequence, as shown in the following figure.



Figure 3-21 Return Function

Loop - The function of this command is to make all the steps between Loop command and Next command repeat the set number of times, the maximum is 65535 times, and after executing the set number of times, continue to execute the steps after Next command. The number of repetitions is selected by and , and the value of the parameter is adjusted by the numeric keys or using the knob, as shown in Figure 3-22.

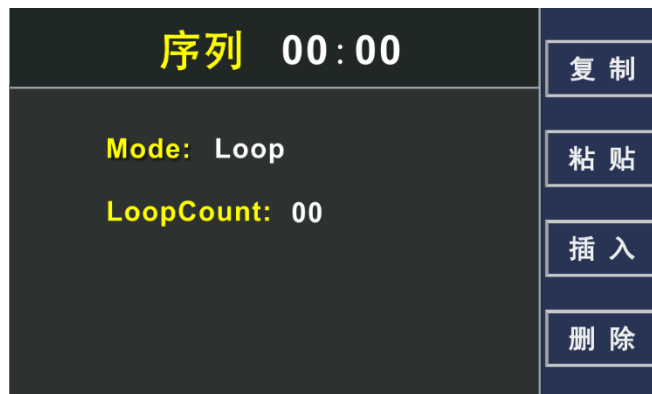

Figure 3 -22 Loop Control Function

Next - This command is used in conjunction with the Loop command. This command is placed after the last step of the loop execution, indicating that the steps between Loop and Next are repeatedly executed. If there is no Loop command before Next when the sequence test is running, the sequence test is stopped and returned to the main interface of the sequence test, as shown in Figure 3-23.



Figure 3-23 Loop end control

Stop - Stops the sequence test and returns to the main sequence test interface, while maintaining the last output value. This command is commonly used in the last step of the sequence to stop a test, as shown in Figure 3-24.



Figure 3-24 Stop Sequence Test

Goto - This command allows the user to exit the current sequence and start another sequence at the same time. It is used to unite multiple sequences, and to form a test, and is often used in the last step of the sequence. Select the sequence number to be jumped by \uparrow , \downarrow , and adjust the value of the parameter by numeric keys or using the knob, as shown in Figure 3-25.



Figure 3-25 Jump Control Function

Pause - This command is used to pause the sequence test, as shown in Figure 3-26.



Figure 3-26 Pause Function

3.2.9.5 Sequence Parameter Deletion

In the main interface of sequence test, press **F4** to enter the sequence deletion interface, as shown in Figure 3-27.



Figure 3-27 Sequence Deletion Interface

Press **F1** to confirm the deletion and return to the main interface of sequence test, this operation will set all the steps in the currently selected sequence to NOP. **F4** is to cancel the deletion and return to the main interface of sequence test.

3.2.9.6 Sequence Test Example

A typical aging test proceeds as follows: the voltage is first fed to the DUT at a certain slope for a certain period of time, then suddenly ramps up to another voltage for a certain period of time, then ramps up again for a certain period of time....., and finally drops to zero at a slope mode. In some cases, a sequence of voltage switching cycle tests is also required, as shown in Figure 3-28 which gives a voltage waveform for aging tests.

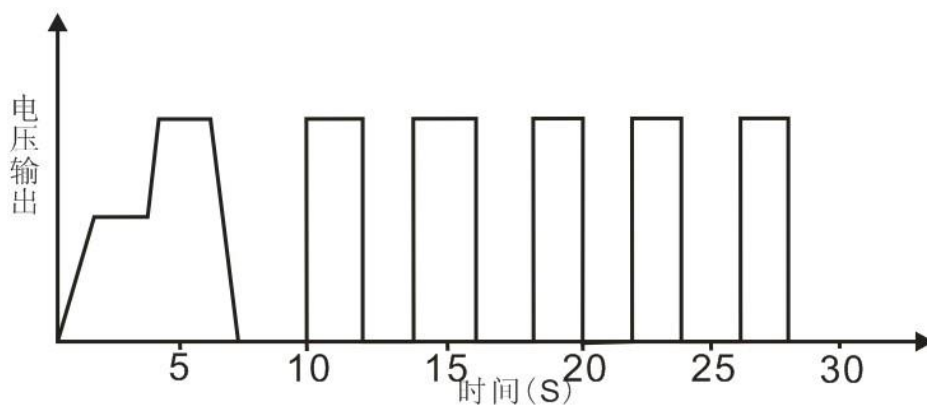

Figure
Sequence
Distance

3-28
Test

Implementing this waveform starts with knowing how to set up each step correctly. That waveform above requires two sequences to complete, one to implement the voltage ramp up, continues and down. The other implements the output of the voltage and stop loop. These two sequences are interconnected by the Goto instruction.

Sequence 1: TEST00

- Step 1 - Output from 0V to 20V in a slope mode for 1s.
- Step 2 - Hold 20V output for 2s.
- Step 3 - Ramp up from 20V to 40V in a ramp mode for 500ms.
- Step 4 - Hold 40V output for 2.5s.
- Step 5 - Decrease from 40V to 0V in a slope mode for 2s.
- Step 6 - Hold 0V output for 2s.
- Step 7 - Goto sequence 2.

Sequence 2: TEST01

- Step 1 - Use the loop command with a loop count of 5 times.
- Step 2 - Output 40V in voltage/current mode for 2s.
- Step 3 - Output 0V in voltage/current mode for 2s.
- Step 4 - Execute Next command after 5 loops.
- Step 5 - Stop the sequence test.

Please follow the steps below to edit the parameters of the sequence:

Sequence 1: In the standby interface, press **F3** to enter the main interface of sequence test, use the numeric keys or knob to adjust the sequence number, select TEST00, then press **F4** to delete TEST00, the deletion operation makes all the steps of TEST00 set to NOP to reset to a definite state. After deleting, press **F3** to enter the sequence parameter editing interface.

Step 1 - Output from 0V to 20V in a slope mode for 1s.

Select step 0 of sequence 0, i.e. TEST00:00, then **↓** key to invert the step function selection position, set the function to Ramp V mode, continue to select the parameters to be set by **↑**, **↓**, use the numeric keys or knob to set V_i to 0V, V_f

to 20V, current limit (need to be set according to the actual load condition, here it is assumed that the load is light and set to 1A), set the duration to 1s (0:00:01:000). After editing, press **F1** to copy the current step parameters to the buffer for later steps.

Step 2 - Hold 20V output for 2s.

↑, **↓** reverse the step number position, select step 1 of sequence 0, i.e. TEST00:01, then **↓** key reverse the step function selection position, set the function to VI Mode, continue to select the parameters to be set by **↑** and **↓**, use the numeric keys or knob to set V to 20V, I to 1A, P to 1kW, and set the duration to 2s (0:00:02:000).

Step 3 - Ramp up from 20V to 40V at a slope mode for 500ms.

↑, **↓** reverse the step number position, select step 2 of sequence 0, i.e. TEST00:02, then press **F2** to copy the parameters of TEST00:00 to the current step, continue to select the parameter to be modified by **↑**, **↓**, use the numeric keys or knob to modify Vi to 20V, Vf to 40V, and modify the duration to 500ms (0:00:00:500).

Step 4 - Hold 40V output for 2.5s.

↑, **↓** reverse the step number position, select step 3 of sequence 0, i.e. TEST00:03, then **↓** key reverse the step function selection position, set the function to VI Mode, continue to select the parameter to be set by **↑** and **↓**, use the numeric keys or knob to set V to 40V, I to 1A, P to 1kW, and set the duration to 2.5s (0:00:02:500).

Step 5 - Fall from 40V to 0V in a slope mode for 2s.

↑, **↓** reverse the step number position, select step 4 of sequence 0, i.e. TEST00:04, then press **F2** to copy the parameters of TEST00:00 to the current step, continue to select the parameters to be modified by **↑**, **↓**, use the numeric keys or knob to modify Vi to 40V, Vf to 0V, and modify the duration to 2s (0:00:02:000).

Step 6 - Hold 0V output for 2s.

↑, **↓** reverse the step number position, select step 5 of sequence 0, i.e. TEST00:05, then **↓** key reverse the step function selection position, set the function to VI Mode, continue to select the parameter to be set by **↑** and **↓**, use the numeric keys or knob to set V to 0V, I to 1A, P to 1kW, and set the duration to 2s (0:00:02:000).

Step 7 - Jump to Sequence 2.

↑, **↓** reverse the step number position, select step 6 of sequence 0, i.e. TEST00:06, then **↓** key reverse the step function selection position, set the function to Goto, select the parameter to be set by **↑**, **↓**, use the numeric keys or knob to set the sequence to be jumped to TEST01. Press **CANCEL** to enter the sequence parameter saving interface,

prompt whether to save TEST00, select **F1** to save.

Sequence 2: In the standby interface, press **F3** to enter the main sequence test interface, use the numeric keys or knob to adjust the sequence number, select TEST01, then press **F4** to delete TEST01, the deletion operation makes all the steps of TEST01 set to NOP to reset to a definite state. After deleting, press **F3** to enter the sequence parameter editing interface.

Step 1 - Set the loop command with a loop count of 5 times.

Select step 0 of sequence 1, i.e. TEST01:00, then **↓** key reverse the step function selection position, set the function to Loop, press **↓** to select the parameter to be set, and use the numeric keys or knob to set the number of loops to 5.

Step 2 - Output 40V in voltage/current mode for 2s.

↑, **↓** reverse the step number position, select step 1 of sequence 1, i.e. TEST01:01, then **↓** key reverse the step function selection position, use the numeric keys or knob to set the function to VI Mode, continue to select the parameters to be set by **↑**, **↓**, set V to 40V, I to 1A, P to 1kW, set the duration to 2s (0:00:02:000), press **F1** to copy the parameters of the current step to the buffer for later use.

Step 3 - Hold 0V output for 2s.

↑, **↓** reverse the step number position, select step 2 of sequence 1, i.e. TEST01:02, then **F2** paste the function of TEST01:01 to the current step and modify the voltage value V to 0V.

Step 4 - Execute the Next command after looping 5 times.

↑, **↓** reverse the step number position, select step 3 of sequence 1, i.e. TEST01:03, then **↓** key reverse the step function selection position, use the numeric keys or knob to set the function to Next.

Step 5 - Stop the sequence test.

↑, **↓** reverse the step number position, select step 4 of sequence 1, i.e. TEST01:04, then **↓** key reverse the step function selection position, use the numeric keys or knob to set the function to Stop. Press **CANCEL** to enter the sequence parameter saving interface, prompt whether to save TEST01, select **F1** to save.

The above completes the editing of the whole program. In the main interface of sequence test, press **F1** to start the sequence test execution, the whole sequence takes about 30s.

3.2.10 Function Output

The machine can output sine wave, rectangle wave, triangle wave, trapezoidal wave, etc. according to the set voltage or current, as shown in Figure 3-29, set the function type as sine

wave, set the output voltage or current, Amp: the amplitude of signal generated, Offset: the offset based on zero point, not less than the assigned value, Value: limited current value, Freq: the frequency of the output signal. When the parameters are set, the output voltage or current depicts a sinusoidal waveform under the premise that the load resistance value is constant.

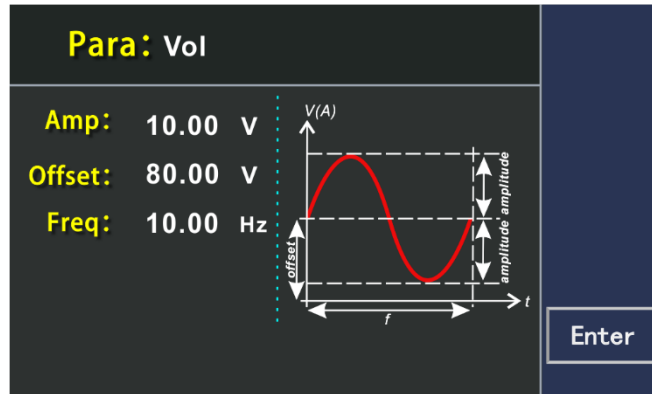

Figure 3-29 Output Sine Wave

Figure 3-30 shows the triangle waveform parameter settings, setting the signal amplitude, the offset value based on the bottom of the triangle waveform, the positive slope time of the triangle waveform, and the negative slope time of the triangle waveform. The sum of the positive slope time and the negative slope time of the triangle waveform is the cycle time, and its inverse is the frequency generated by the triangle waveform.

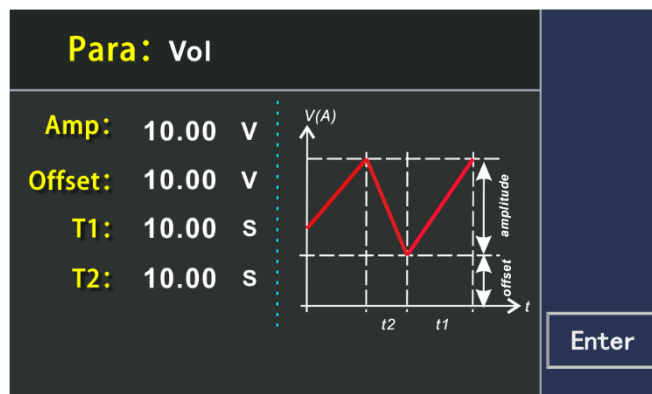

Figure 3-30 Output Triangle Waveform

Figure 3-31 shows the rectangular waveform parameter settings, setting the signal amplitude, the offset value based on the bottom of the rectangular waveform, the peak time of the rectangular waveform, and the reference time of the rectangular waveform. The sum of the peak time of the rectangular waveform and the reference time of the rectangular waveform is the cycle time, its reciprocal is the frequency generated by the triangle waveform, and the duty cycle can be defined as needed.

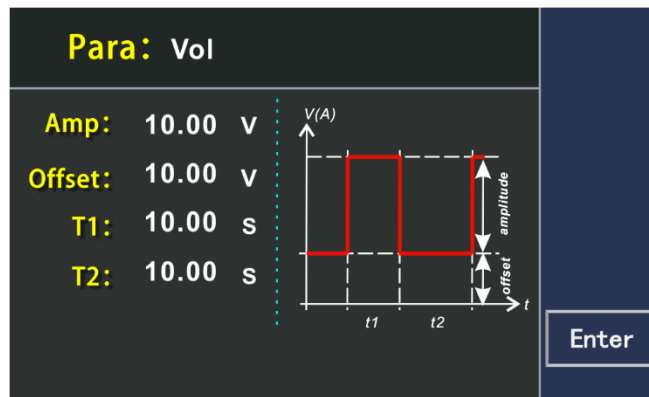

Figure 3-31 Output Rectangular Waveform

Figure 3-32 shows the trapezoidal waveform parameter setting, setting the signal amplitude, offset value based on the bottom of the trapezoidal waveform, the negative slope time of the trapezoidal waveform signal, the top value time of the trapezoidal waveform signal, the positive slope time of the trapezoidal waveform signal, and the basic value of the trapezoidal waveform signal, set different gain and attenuation time can form trapezoidal waveform with different slopes. The period time and repetition frequency are determined by these four times.

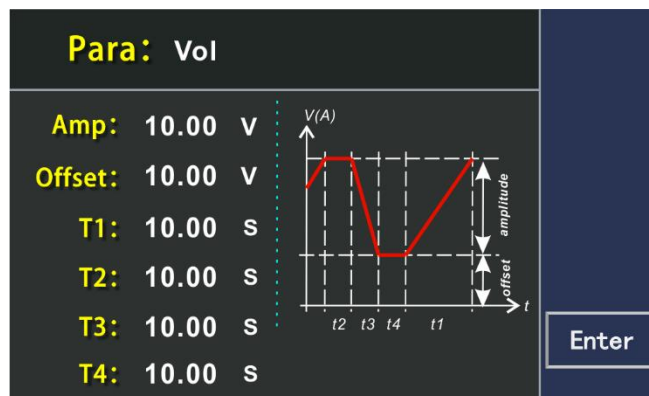

Figure 3-32 Output Trapezoidal Waveform

Based on these waveforms, users can form a sequence output, and the sequence can set up to ten steps, each step can set any kind of waveform and the duration of the sub-waveform, which is convenient for users to test products.

Copy: Copy the function type and parameter setting value of the current step;

Paste: Paste the copied function type and parameter values to the current step;

Insert: Insert a function output item in the sequence; Delete: Delete a function output item in the sequence.

3.2.11 Solar Array Simulation Capabilities

TH6900 power supply is equipped with solar array simulation function. In addition to the CC/CV mode and EN50530 mode output through the host software, the stand-alone unit also has a built-in model for simulating solar array output curve. The model

follows the following equation:

$$I = I_{sc} \left[1 - C_1 \left(e^{\frac{V}{C_2 V_{oc}}} - 1 \right) \right]$$

Among

$$C_1 = \left(1 - \frac{I_{mp}}{I_{sc}} \right) e^{\frac{-V_{mp}}{C_2 V_{oc}}}$$

$$C_2 = \frac{\frac{V_{mp}}{V_{oc}} - 1}{\ln \left(1 - \frac{I_{mp}}{I_{sc}} \right)}$$

V_{oc} : open-circuit voltage;

I_{sc} : short-circuit current;

V_{mp} : maximum power point voltage;

I_{mp} : maximum power point current;

The output curve is shown in Figure 3-33:

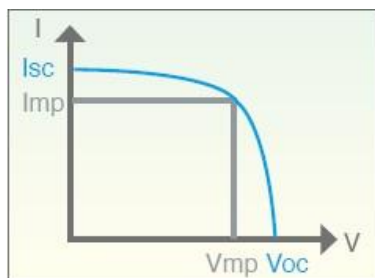

Figure 3-33 I-V Mode Output Curve

In addition, the factor of the model formula will make the V_{mp} and I_{mp} entered by the user different from the V_{mp} and I_{mp} of the maximum power point derived by the formula, and the difference will be larger when the fill factor is smaller.

Description:

1. Fill factor (FF) definition : $\frac{V_{mp} I_{mp}}{V_{oc} I_{sc}}$
2. V_{oc} , I_{sc} , V_{mp} , I_{mp} parameter setting limits:
 - $V_{oc} > V_{mp} > 0$
 - $I_{sc} > I_{mp} > 0$
 - $V_{mp} > V_{oc} \left(1 - \frac{I_{mp}}{I_{sc}} \right)$

Setting method:

Press **F3** in the standby interface to enter the SAS function interface, as shown in Figure 3-34. Select the parameter to be edited by **↑**, **↓**, and use the numeric keys or knob to change the value of the parameter.



Figure 3-34 SAS Function Setting Interface

After the parameter editing is finished, use **Enter** or **F3** key to confirm. If the parameter setting exceeds the range of the setting limit, the system will display an error message on the interface and will not respond to this key operation, as shown in Figure 3-35.



Figure 3-35 Parameter Setting Error

After editing the parameter to report an error, re-edit the parameter correctly to clear the error report. After finishing the parameter editing, use the **ON/OFF** key to start the output, as shown in Figure 3-36.



Figure 3-36 SAS Function Start Output

After the function is activated, all the keys except **ON/OFF** key are locked and the operation is invalid. Press the **ON/OFF** key again to stop the output.

3.2.12 Parallel Operation

This series of power supply models with the same specifications can be used in parallel, and parallel connection can increase the power output capacity and output current. When connecting in parallel, simply connect the DC output terminals of each unit to each other. Choose the wire diameter according to the maximum current and use the shortest possible wire. The master-slave connection terminals are built-in, so please use the attached connection cable to connect them. Up to 10 power supplies of the same type can be connected in parallel. There are two 9-pin connectors on the rear panel of the chassis, labeled "PAR OUT" and "PAR IN" respectively. Through these two connectors, use the "Master/Slave" mode to achieve parallel connection. Please follow the steps below:

1. First select a host (Master), the host user can choose, then connect the "PAROUT" interface on the rear panel of the master to the "PAR IN" interface of the other power supply (Slave 1) through the parallel signal cable.
2. Connect the "PARA OUT" interface of Slave1 to the "PARIN" interface of of the third power supply, Slave2, through the parallel signal cable, and continue to connect up to 10 power supplies according to this procedure.
3. Connect the positive output terminals of all power supplies together and to the load.
4. Connect the negative output terminals of all power supplies together and to the load.
5. Check the connections to make sure there are no short connections between positive and negative.
6. To connect the SENSE lines, the SENSE lines of all slaves are connected directly to the positive and negative terminals of their outputs, and the master has the following two connections: Using the lead drop compensation function: the SENSE lines of the master are connected to both ends of the load. Without lead drop compensation function: the SENSE of the master is connected directly to the positive and negative terminals of its output. Use twisted pairs for all SENSE lines and keep them as short as possible. When using the lead drop compensation function, the voltage display of the slave will be slightly higher than that of the master.

The parallel setup interface allows you to set the machine to stand-alone mode, master mode, and slave mode.

1. Stand-alone mode

When the machine is not used as a parallel machine, it should be set to stand-alone mode.

2. Master mode

Set the machine to master mode as shown in Figure 3-37. The master-slave system in master mode must perform the initialization operation, and the master will automatically search for slaves and then configure the corresponding set

and actual values for this machine. If one or more correctly configured slaves are found, the number of slaves with the addresses of the slaves and the total current and total power integrated will be displayed on the master screen. If no slave is found or the number displayed is incorrect, check the connections and settings between all slaves and the master, then repeat the setup procedure.

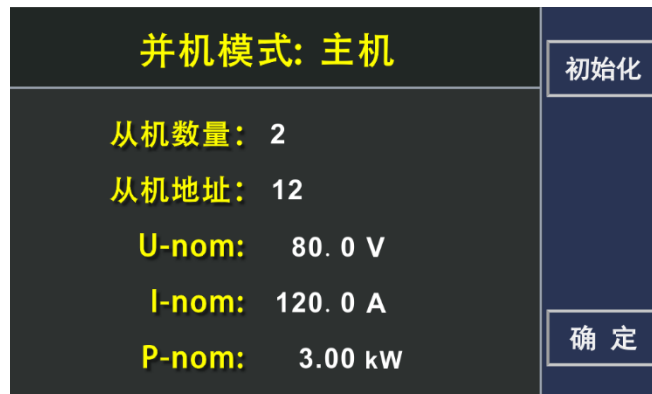

Figure 3-37 Slave Mode

- Set the machine to slave mode as shown in Figure 3-38. You need to set the slave address in slave mode, and pay attention to the slave addresses cannot be duplicated when there are multiple slaves.

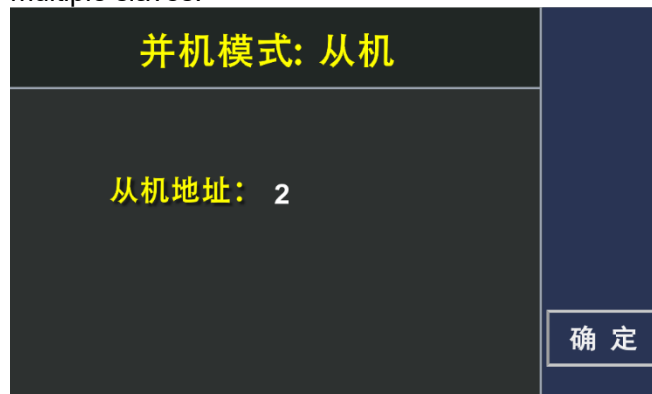

Figure 3-38 Slave Mode

After editing the mode, press F4 to save to return to the standby interface. If more than one slave machine has an alarm message, it will be displayed on the master, and it must be confirmed that it is slave before continuing operation, because the alarm will cause the DC output to be turned off and needs to be turned on again; if any slave machine has a loose connection, it will cause the DC outputs to be disconnected, and for safety reasons, the master will report this status, and the system needs to be reinitialized at this time.

3.2.13 Output slope setting

This series of power supply has adjustable rising edge and falling edge speed. Various modes (source CV, CC, CP) support setting rising and falling time c_{in} in the range of 0.01s~999.99s. Users can set the rising and falling time for voltage, current and power. The unit time is seconds (S). Each setting item can be selected by the

up and down arrow keys. The rise time can be adjusted by the numeric keys or knob.

V-Rise/V-Fall: voltage rise slope and fall slope.

I-Rise/I-Fall: current rise slope and fall slope.

P-Rise/P-Fall: power rise slope and fall slope.

The rise/fall time is the time for one voltage point to rise/fall to another voltage point when the power supply output is On. To observe the slope of a voltage drop to 0V, you need to set 0V by [V-set] and press [Enter] to confirm that the voltage starts to drop according to the set drop rate.



Figure 3-39 Output Slope Setting

3.2.14 Analog Interface Control (Optional)

The product has a built-in 15-pin analog interface on the rear panel with isolation withstand voltage up to 1000VDC, which has the following functions:

- (1) Remote control of voltage, current and power;
- (2) Remote monitoring of operating status (CC/CP, CV);
- (3) Remote monitoring alarm status (OT, OVP);
- (4) Remote monitoring of actual voltage and current output values;
- (5) Turn the DC output on or off remotely.

The setting of the three resistance values of voltage, current and power, via the analog interface, generally occurs synchronously and cannot be set via the analog control interface for voltage, but through the front panel knob for current and power, and vice versa. The OVP setting value, and other monitoring events and alarm limits cannot be set via the analog control interface, which can be operated in the general voltage range of 0 to 5V and 0 to 10V. They correspond to a selectable voltage range from 0 to 100% of the rated value. When the input exceeds the set value, it will be replaced by 100% of the set value.

The analog interface should be used with the following in mind:

- (1) The "remote" pin must first be used to activate the analog remote control;
- (2) Before connecting the hardware of the analog control

interface, ensure that no voltage higher than the specified value is output to the pin;

- (3) The setpoint input pin cannot be left dangling;
- (4) Requires three sets of set values to be provided each time.

3.2.14.1 Analog Control Interface Description

The analog interface control function allows the user to control the power supply via external analog signals, including: voltage, current, power setting, start/stop and other functions, which will be described in detail in the next sections. When setting the voltage, current and power values through the analog interface, what actually works is the sum of the value set through the analog interface and the value on the front panel, so if you want to control the power supply through the analog interface only, you need to set the value on the front panel to 0.

In addition, an optional isolated analog control interface is available, which completely isolates the ground of the external control signal from the ground of the power supply. In this case, some signals of the analog control interface are not available, and the analog interface pin are defined as shown in the table below.

Pin	Symbol	Description	Default level	Electrical Characteristics
1	R_ACTIVE	Resistance mode switch		
2	DGND	Digital		For control and status signals
3	AGND	Simulated		Analog signal ground
4	AN_UREF	Reference voltage	10V or 5V	Error is less than 0.2%, short-circuit protection to AGND
5	I_MON	Actual current	0~10V or 0~5V corresponds to 0~100% I _{Nom}	The accuracy is less than 0.2%, and the input impedance is greater than 40K
6	I_PROG	Set current	0~10V or 0~5V corresponds to 0~100% I _{Nom}	The accuracy is less than 0.2%, and the input impedance is greater than 40K
7	U_MON	Actual voltage	0~10V or 0~5V corresponds to 0~100%U _{Nom}	The accuracy is less than 0.2%, and the input impedance is greater than 40K
8	U_PROG	Set voltage	0~10V or 0~5V corresponds to 0~100%U _{Nom}	The accuracy is less than 0.2%, and the input impedance is greater than 40K
9	P_PROG	Set power	0~10V or 0~5V corresponds to 0~100% P _{Nom}	The accuracy is less than 0.2%, and the input impedance is greater than 40K
10	CV	Constant voltage adjustment activation	Constant voltage adjustment activation	Short-circuit protection for DGND

11	R_PROG	Set internal resistance	0~10V or 0~5V corresponds to 0~100% R Nom	The accuracy is less than 0.2%, and the input impedance is greater than 40K
12	OVP	Overvoltage alarm	Overvoltage alarm	Short-circuit protection for DGND
13	OT	Overheating or power failure alarm	Overheating or power failure alarm	Short-circuit protection for DGND
14	RSD	Power start/stop	DC output off: LOW is less than 1V DC output on: HIGH is greater than 4V	Voltage range: 0~30V, sender: Collector to DGND open
15	REMOTE	Open internal control/remote control	Remote: LOW is less than 1V Internal control: HIGH is greater than 4V	Voltage range: 0~30V, sender: Collector to DGND open

The functions and definitions of specific pins are shown in Table 3-1:

Table 3-1 Analog Interface Pin Configuration

* When the isolated analog control interface is selected, the ground of the control signal is isolated from the ground of the power supply.

** This signal is not available when the optional isolated analog control interface is fitted.



注意

If a standard analog control interface is used, not that the common ground is equipotential to the negative side of the power supply output. Improper connections may result in backflow and consequent damage to the internal circuitry of the power supply.

3.2.13.2 Set Output Voltage, Current and Power Values

Through the analog control interface, you can set the power supply voltage, current and power value, an external resistor or a voltage signal on the analog interface can be set to the power supply, when using the analog interface control, in order to minimize the noise interference to the signal, it is recommended to use shielded twisted pair cable. This feature enables the output of the voltage to be changed by an external analog signal by connecting an external DC voltage (voltage mode) or an external resistor (resistor mode) to pins 6, 8 and 9. To enable this feature, the output control must be in the external analog control mode. The external voltage range used to control the full scale output voltage can be selected from 0 to 5V/0 to 10V or resistor in 10KΩ. Figure 3-40 and 3-41 show the wiring diagrams for the external voltage source and external resistor, respectively.

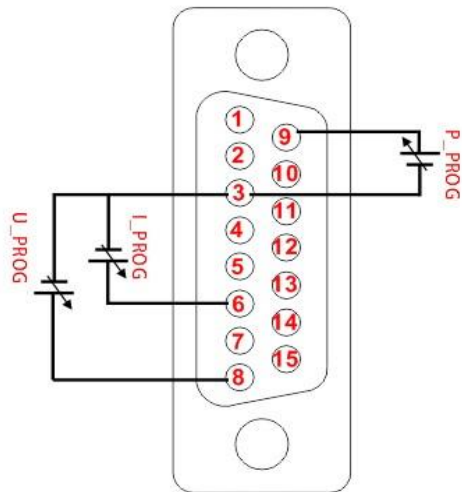

Figure 3-40 Set Voltage, Current and Power Values with External Voltage Source

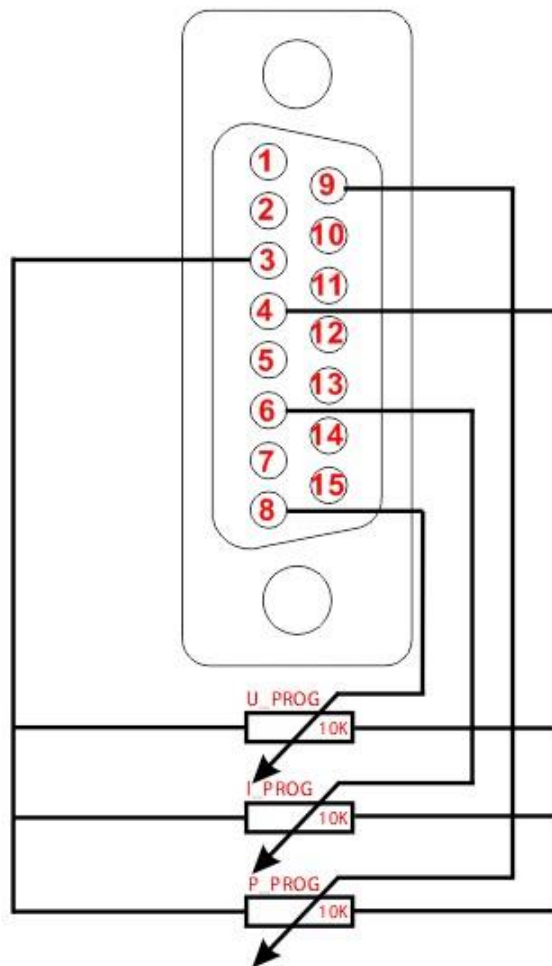

Figure 3-41 Set Output Voltage, Current and Power Values Through Resistors

3.2.14.3 Read Actual Values of Voltage and Current

This feature enables the voltage, current output to be monitored using pins 5, 7 and the ground pin (i.e. pin 3), which can be

connected to a digital voltmeter (DVM). The output voltage monitoring range (reflecting the power supply output voltage and current from zero to full scale) can be selected between 0 to 10V or 0 to 5V. The wiring is shown in Figure 3-42.

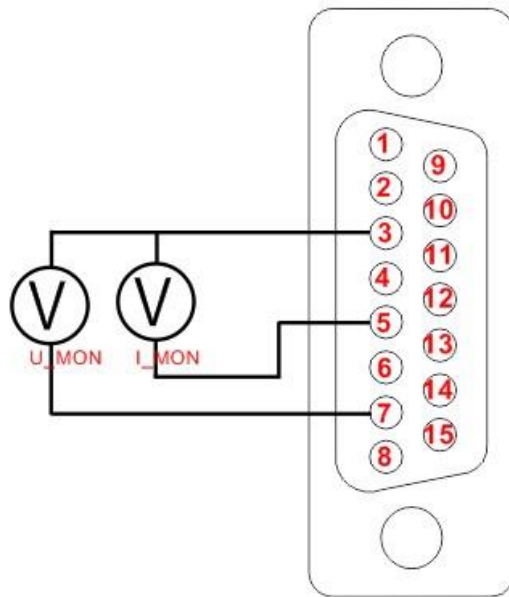

Figure 3-42 Monitor Output Voltage and Current Value

Chapter 4 Troubleshooting & Maintenance

4.1 Care and Maintenance

4.1.1 Regular Maintenance

If the equipment is not used for a long time, it should be energized once a month, and the energizing time should not be less than 30 minutes.

4.1.2 Routine Maintenance

It is recommended that the following work be done at least once a year

- (1) Regularly check whether the insulation of the input and output wires and terminals of the instrument are damaged, and replace them in time if they are damaged to avoid electric shock.
- (2) Regularly check that the input and output wiring is secure to prevent overheating due to loose electrics.
- (3) Regularly check all warning signs on the instrument and replace all warning signs that are not easily visible in a timely manner.
- (4) Visually inspect all exposed parts.

4.1.3 User Maintenance

It is forbidden to open the case of the instrument without permission to prevent accidental electric shock; moreover, it is forbidden to change the wiring or parts of the instrument without permission, if there is any change, the quality assurance commitment of the instrument will be automatically invalid. If the instrument is found to have been altered without authorization, our technical staff will restore the instrument and charge the repair cost.



Non-professional personnel should not open the instrument by themselves to avoid injury or damage to the equipment.

4.1.4 Maintenance and Care During Long-term Non-use

- (1) Long-term storage of instruments pay attention to the storage environment, see section 2.2 for details.
- (2) Please clean the dust on the surface of the instrument briefly before turning on the machine.
- (3) See Chapter 3.2 for details of the pre-start-up preparation

checks.

- (4) After turning on the machine, observe whether the instrument operates normally, if there is any abnormality or failure, please stop using it immediately, unplug the power cord or disconnect the power from the power distribution box, and do not use the product until it is repaired.

4.2 Simple Troubleshooting



注意

Equipment must be repaired and maintained by experienced professionals. Repair and maintenance by personnel without qualified training may result in personal injury or death.

Symptoms	Cause Analysis	Troubleshooting
OVP alarm	<ol style="list-style-type: none"> The actual output value is greater than the set OVP value S-terminal feedback line is reversed 	<ol style="list-style-type: none"> Reset the appropriate OVP value Detect whether the positive and negative ends of the S terminal are connected wrongly
Hardware error alarm	<ol style="list-style-type: none"> Internal machine overheating Internal function module failure 	<ol style="list-style-type: none"> Clear alarm and detect whether the ambient temperature is too high If the alarm cannot be cleared, please contact Changzhou Tonghui Electronics Co., Ltd. or your local distributor
No display on boot	<ol style="list-style-type: none"> Three-phase power supply abnormalities (phase loss, over-undervoltage) Low ambient temperature 	<ol style="list-style-type: none"> Observe whether the three-phase power supply wiring is good, and measure whether the three-phase power supply meets the requirements Please leave it at room temperature for a period of time before starting
Large error in actual output voltage	<ol style="list-style-type: none"> Enter restricted-current mode Unconnected S terminal feedback line 	<ol style="list-style-type: none"> Observe the CV/CC indicator on the front panel Connect the S-terminal feedback wire to the DC output terminal or the load

4.3 Storage & Transport

4.3.1 Storage

Storage environment temperature: -25~65°C

Storage relative humidity: not more than 80% (high humidity environment storage, it is recommended to run the machine regularly for 20 minutes to avoid water vapor condensation).



Dustproof measures should be taken when storing, and it is forbidden to stack any items on the instrument.

4.3.2 Transport

4.3.2.1 Packaging

The instrument should be returned for repair or shipped in its original packaging. If the original packaging cannot be found, be sure to pack it accordance with the following requirements:

- (1) First seal the instrument in a plastic bag;
- (2) Then place the equipment in a wooden box or multi-layer carton that can withstand a weight of 50kg;
- (3) Must use shockproof material filling, thickness of about 60mm, and the panels must be protected by thick plastic foam;
- (4) Properly seal the box, and indicate with a conspicuous sign "Fragile, please handle with care".



When returning for repair, please be sure to package all accessories such as power cord and test cable with the instrument, and please indicate the fault phenomenon.

4.3.2.2 Transportation

During transportation, violent bumps, brutal loading and unloading, rain and inversion should be avoided.

Chapter 5 DC Test Power Supply Communication Protocol

5.1 Communication Protocol Command Format

5.1.1 Communication Mode

RS232 or RS485, default is RS232. The PC is the master by default, and the standard unit is the slave. Master-slave response mode is adopted, and the slave does not send data to the master when the address does not match.



注意

When using remote operation, the power supply and the computer must be grounded at the same time and hot-plugging is prohibited to avoid damage to the power supply or the computer.

5.1.2 Baud Rate

1200, 9600, 19200, 38400, default is 38400.

address range

001~255.

data frame format

1 start bit, data bit, 1 stop bit.

The Accepted Data Frame Format is as Follows

Frame Header	Total Bytes	Slave Address	Command			Checksum	End of Frame
			Type	Command Word	Parameter		
0x7B	XX	X	X	X		X	0x7D

Note:

1. Each X represents a byte count.
 2. The number of bytes of command parameter varies depending on the length of the parameters carried by the specific command.
1. Frame header: 1 byte, fixed to 0x7B, which is the ASCII code of '{'.
 2. Total bytes: 2 bytes, the value is the sum of the frame header + total bytes + slave address + command type + command

word + command parameters + checksum + number of bytes at the end of the frame, the high byte is in the front and the low byte is after.

3. Slave address: 1 byte

0x00 is used as a special address for system broadcast. All devices in the address range of 0x01~0xFF can receive broadcast commands, but can only execute other types of commands except query class, and do not return answers to control, setup and debug commands at this address.

4. Command:

A. Types: The commands are classified into the following categories according to the different functions of the communication commands:

a) Control class: 0x0F, contains commands for all control operations of the slave, such commands should be without any parameters.

b) Query class: 0xF0, contains all commands of the slave without parameter query operation command. That is, query the measured value and query the self-test status command class.

c) Query class with parameter: 0xF1, contains all commands of the slave with one parameter query operation.

d) Query setting class: 0xA5, contains all query setting parameter operations of the slave.

e) Setting class: 0x5A, contains commands for all setting operations of the slave.

f) Error class: 0x99, the command returned when the slave receives an error command.

g) Debug class: 0x3C, contains commands for all debug check operations of the slave.

B. Command word: 1 byte, which indicates a specific command in a command type, and the specific operation can be performed according to the command type and command word slave function.

C. Parameters: See the specific command. It is required that all digital quantities are expressed in hexadecimal numbers (the parameter string does not contain units), and the unit is unified as the corresponding unit of the minimum resolution of the corresponding parameter, e.g.: the minimum current setting value of model 61015-600 is the resolution of 0.1A, then the unit of the parameter is 0.1A. When a parameter needs to be expressed in multiple bytes, the high byte is in the front and the low byte is after.

5. Checksum: 1 byte (hexadecimal number), which is the result of checksum of the sent data. The checksum adopts horizontal checksum, that is, the sum of total bytes + slave address + command, and the take the low byte as the checksum.

6. End of Frame: 1 byte, fixed to 0x7D, i.e. ASCII code of '}'.

5.2 Summary Table of Communication Protocol Commands

Command Class	Command			Functional meaning
	Type	Command Word	Parameter	
Control Class	0x0F	0x00		Stop
		0x01		Start up
		0x02		Reset to factory state
		0x03		Dismiss the alarm
Query Class	0xF0	0x00		Output states (non-starting, CC, CV)
		0x10		Voltage output value
		0x11		Current output value
		0x12		Power output value
		0x80		Query voltage, current and power output value
		0xEB		Query current status
		0xED		Query model
		0xEF		Query software version
Query Class with Parameters	0xF1	0x50	X	Data of a certain group (voltage, current, power)
		0x51	X	Voltage of a group
		0x52	X	Current of a group
		0x55	X	Power of a group
Query Setting Class	0xA5	0x00		Query the set voltage value
		0x01		Query the set current value
		0x02		Query the set power value
		0x06		Query Ramp voltage value
		0x07		Query Ramp current value
		0x10		Query whether the OPV function is enabled
		0x12		Query the total system current
		0x40		Query SAS mode setting values (Voc, Isc, Vmp, Imp)
		0x41		Query the set Voc value
		0x42		Query the set Isc value
		0x43		Query the set Vmp value
		0x44		Query the set Imp value
Setting Class	0x5A	0x00	XX	Set voltage value
		0x01	XX	Set current value
		0x02	XX	Set power value
		0x40	XXXX	Set SAS data (Voc, Isc, Vmp, Imp)
		0x51	XX	Set the current group serial number
		0x52	XX	Set the current group voltage value
		0x53	XX	Set the current group current value
		0x54	XX	Set the current group power value
		0x55	XX	Save the specified group
Sequence Test Setup Class	0x5C	0x01	X	Select the specified sequence
		0x03		Define the function, parameters of the selected step

		0x04		Store the current sequence
		0x05		Delete the current sequence
		0x07		Start-up sequence test
		0x08		Stop sequence test
		0x09		Pause sequence test
		0x0A		Continue sequence test
Sequence Test Query Class	0xC5	0x00		Query the current serial number
		0x01		Query the current sequence test status

5.3 Communication Protocol Command Description

(1) Control class commands (0x0F)

a) Command word: 00H

Command function: Stop output

Command format: 0x7B XX X 0x0F 0x00 X 0x7D

Command length: 8 Format description: no parameter

Command example: 7B 00 08 01 0F 00 18 7D

b) Command word: 01H

Command function: Start output

Command format: 0x7B XX X 0x0F 0x01 X 0x7D

Command length: 8 Format description: no parameter

Command example: 7B 00 08 01 0F 01 19 7D

c) Command word: 02H

Command function: Reset to factory default state

Command format: 0x7B XX X 0x0F 0x02 X 0x7D

Command length: 8 Format description: no parameter

Command example: 7B 00 08 01 0F 02 1A 7D

d) Command word: 03H

Command function: Restore to standby state when in alarm state

Command format: 0x7B XX X 0x0F 0x03 X 0x7D

Command length: 8 Format description: no parameter

Command example: 7B 00 08 01 0F 03 1B 7D

Note: For the return command format without the return format description in the command, please refer to Section 3 General Return Commands.

(2) Query class commands (0xF0)

a) Command word: 00H

Command function: Query the power supply output status (non-start state, CC, CV)

Command format: 0x7B XX X 0xF0 0x00 X 0x7D

Command length: 8 Format description: no parameter

Command example: 7B 00 08 01 F0 00 F9 7D

Return format: 0x7B XX X 0xF0 0x00 XX 0x7D

Return length: 9

Format description: 1-byte parameter, where the parameter meaning is

1 Non-start state; 3 CV state; 4 CC state;
5 CP state.

Return command example: 7B 00 09 01 F0 00 04 FE 7D

Return command description: In the state of starting CC

b) Command word: 10H

Command function: Query voltage output value

Command format: 0x7B XX X 0xF0 0x10 X 0x7D

Command Length: 8

Format description: no parameter

Command example: 7B 00 08 01 F0 10 09 7D

Return format: 0x7B XX X 0xF0 0x10 XXX X 0x7D

Return length: 11

Format description: 2 bytes 1 parameter, the parameter is the hexadecimal value of the voltage output value, the value is the decimalized value of the data

Return command example: 7B 00 0B 01 F0 10 00 06 FD 0F 7D

Return command description: The output voltage is 17.89V (assuming 61015-600 with a resolution of 0.01 in front of the 2nd digit at the beginning of the lower decimal place)

c) Command word: 11H

Command function: Query current output value

Command format: 0x7B XX X 0xF0 0x11 X 0x7D

Command length: 8

Format description: no parameter

Command example: 7B 00 08 01 F0 11 0A 7D

Return format: 0x7B XX X 0xF0 0x11 XX X 0x7D

Return length: 10

Format description: 2 bytes 1 parameter, the parameter is the hexadecimal value of the voltage output value, the value is the decimalized value of the data

Return command example: 7B 00 0A 01 F0 11 00 45 51 7D

Return command description: The output current is 0.69A (assuming 61015-600 with a resolution of 0.01 in front of the 2nd digit at the beginning of the lower decimal place)

d) Command word: 12H

Command function: Query power output value

Command format: 0x7B XX X 0xF0 0x12 X 0x7D

Command length: 8

Format description: no parameter

Command example: 7B 00 08 01 F0 12 0B 7D

Return format: 0x7B XX X 0xF0 0x11 XX X 0x7D

Return length: 10

Format description: 2 bytes 1 parameter, the parameter is the hexadecimal value of the voltage output value, the value is the decimalized value of the data

Return command example: 7B 00 0A 01 F0 12 00 01 0E 7D

Return command description: The output power is 0.01kW (assuming 61015 series, which has a resolution of 0.01 in front of the 2nd digit at the beginning of the lower decimal place)

e) Command word: 80H

Command function: Query voltage, current, and power output value

Command format: 0x7B XX X 0xF0 0x80 X 0x7D

Command length: 8

Format description: no parameter

Command example: 7B 00 08 01 F0 80 79 7D

Return format: 0x7B XX X 0xF0 0x80 XX X 0x7D

Return length: 15

Format description: 7 bytes 3 parameters, respectively voltage, current and power.

Return command example: 7B 00 0F 01 F0 80 00 06 FD 00 45 00 01 C9 7D

Return command description: 17.89V, 0.69A, 0.01kW.

- f) Command word: EBH
Command function: Query current status
Command format: 0x7B XX X 0xF0 0xEB X 0x7D
Command length: 8
Format description: no parameter
Command example: 7B 00 08 01 F0 EB E4 7D
Return format: 0x7B XX X 0xF0 0xEB XX 0x7D
Return length: 9
Format description: 1 byte 1 parameter:
1 standby state; 2 start-up state; 3 hardfault alarm; 4 OVP alarm.
Return command example: 7B 00 09 01 F0 EB 01 E6 7D
Return command description: In standby mode
- g) Command word: EDH
Command function: Query the machine model
Command format: 0x7B XX X 0xF0 0xED X 0x7D
Command length: 8
Format description: no parameter
Command example: 7B 00 08 01 F0 ED E6 7D
Return format: 0x7B XX X 0xF0 0xED XX X 0x7D
Return length: 12
Format description: 4 bytes 2 parameters: series of machine, voltage level
Return command example: 7B 00 0D 01 F0 ED 00 EE 84 FA 00 57 7D
Return command description: The model is 61060-250
- h) Command word: EFH
Command function: Query the software version number
Command format: 0x7B XX X 0xF0 0xEF X 0x7D
Command length: 8
Format description: no parameter
Command example: 7B 00 08 01 F0 EF E8 7D
Return format: 0x7B XX X 0xF0 0xEF XX X
Return length: 10

Format description: 2 bytes 1 parameter: the parameter is the hexadecimal value of the software version number, the value is the decimalized value of the data

Return command example: 7B 00 0A 01 F0 EF 00 64 4E 7D

Return command description: The software version number is 1.00

(3) Query class commands with parameters (0x F1)

a) Command word: 50H

Command function: Query the data of the requested storage group

Command format: 0x7B XX X 0xF1 0x50 XX 0x7D

Command length: 9

Format description: 1 parameter (0-9)

Command example: 7B 00 09 01 F1 50 00 4B 7D

Return format: 0x7B XX X 0xF1 0x50 XX X 0x7D

Return length: 14

Format description: 6 bytes 3 parameters: the parameters are voltage, current, and OVP of the step, the value is the decimalized value of the data (set the value resolution to 0.1)

Return command example: 7B 00 0E 01 F1 50 00 28 00 32 00 46 F0 7D

Return command description: The voltage of the current step is 4.0v, the current is 5.0A, OVP is 7.0V.

b) Command word: 51H

Command function: Query the set voltage of the storage group

Command format: 0x7B XX X 0xF1 0x51 XX 0x7D

Command Length: 9

Format description: 1 parameter (0-9)

Command example: 7B 00 09 01 F1 51 00 4C 7D

Return format: 0x7B XX X 0xF1 0x51 XX X 0x7D

Return length: 10

Format description: 2 bytes 1 parameter: the parameter is the hexadecimal value of the set voltage value, the value is the decimalized value of the data

Return command example: 7B 00 0A 01 F1 51 00 28 75 7D

Returns command description: .

c) Command word: 52H
Command function: Query the set current of the storage group
Command format: 0x7B XX X 0xF1 0x52 XX 0x7D
Command length: 9
Format description: 1 parameter (0-9)
Command example: 7B 00 09 01 F1 52 00 4D 7D
Return format: 0x7B XX X 0xF1 0x52 XX X
Return length: 10
Format description: 2 bytes 1 parameter: the parameter is the hexadecimal value of the set current value, the value is the decimalized value of the data
Return command example: 7B 00 0A 01 F1 52 00 32 80 7D
Returns command description: .

d) Command word: 55H
Command function: Query the power value of a certain group
Command format: 0x7B XX X 0xF1 0x53 XX 0x7D
Command length: 9
Format description: 1 parameter (0-9)
Command example: 7B 00 09 01 F1 55 00 50 7D
Return format: 0x7B XX X 0xF1 0x55 XX X 0x7D
Return length: 10
Format description: 2 bytes 1 parameter: the parameter is the hexadecimal value of the set time
Return command example: 7B 00 0A 01 F1 55 00 46 97 7D
Returns command description: .

(4) Query setting class commands (0xA5)

a) Command word: 00H
Command function: Query the set voltage value
Command format: 0x7B XX X 0xA5 0x00 X 0x7D
Command length: 8
Format description: no parameter
Command example: 7B 00 08 01 A5 00 AE 7D
Return format: 0x7B XX X 0xA5 0x00 XX X 0x7D
Return length: 10

Format description: 2 bytes 1 parameter, the parameter is the hexadecimal value of the voltage setting value, the value is the decimalized value of the data

Return command example: 7B 00 0A 01 A5 00 0A 14 CE 7D

Return command description: 0A14: 2580, indicating that the current setting value is 258.0V (assuming 61015-600, the decimal place is in front of the first digit at the beginning of the lower position)

b) Command word: 01H

Command function: Query the set current value

Command format: 0x7B XX X 0xA5 0x01 X 0x7D

Command Length: 8

Format description: no parameter

Command example: 7B 00 08 01 A5 01 AF 7D

Return format: 0x7B XX X 0xA5 0x01 XX X

Return length: 10

Format description: 2 bytes 1 parameter, the parameter is the hexadecimal value of the current setting value, the value is the decimalized value of the data

Return command example: 7B 00 0A 01 A5 01 00 EF A0 7D

Return command description: The current setting value is 23.9A (assuming 61015-600, the decimal place is in front of the first digit at the beginning of the lower position)

c) Command word: 02H

Command function: Query the set power value

Command format: 0x7B XX X 0xA5 0x02X 0x7D

Command Length: 8

Format description: no parameter

Command example: 7B 00 08 01 A5 02 B0 7D

Return format: 0x7B XX X 0xA5 0x90 XX X 0x7D

Return length: 10

Format description: 2 bytes 1 parameter, the parameter is the hexadecimal value of the power value, the value is the decimalized value of the data

Return command example: 7B 00 0A 01 A5 02 00 0A 1A 7D

Return command description: The power setting value is 0.10kW

-
- d) Command word: 40H
Command function: Query SAS mode setting value (V_{oc} , I_{sc} , V_{mp} , I_{mp})
Command format: 0x7B XX X 0xA5 0x40 X 0x7D
Command Length: 8
Format description: no parameter
Command example: 7B 00 08 01 A5 40 EE 7D
Return format: 0x7B XX X 0xA5 0x40 XX XX XX XX X 0x7D
Return length: 16
Format description: 2 bytes 1 parameter, the parameters are the hexadecimal value of V_{oc} , I_{sc} , V_{mp} , I_{mp} , the value is the decimalized value of the data
Return command example: 7B 00 10 01 A5 40 0F A0 00 50 0D AC 00 46 F4 7D
Return command description: set V_{oc} to 400.0V, I_{sc} to 8.0A, V_{mp} to 350.0V, I_{mp} to 7.0A (assuming 61015-600, the decimal place is in front of the first digit at the beginning of the lower position)
- e) Command word: 41H
Command function: Query the set V_{oc} value

Command format: 0x7B XX X 0xA5 0x41 X 0x7D

Command length: 8

Format description: no parameter

Command example: 7B 00 08 01 A5 41 EF 7D

Return format: 0x7B XX X 0xA5 0x41 XX X 0x7D

Return length: 10

Format description: 2 bytes 1 parameter, the parameter is the hexadecimal value of V_{oc} , the value is the decimalized value of the data

Return command example: 7B 00 0A 01 A5 41 0F A0 A0 7D

Return command description: The set V_{oc} is 400.0V (assuming 61015-600, the decimal place is in front of the first digit at the beginning of the lower position)

f) Command word: 42H

Command function: Query the set I_{sc} value

Command format: 0x7B XX X 0xA5 0x42 X 0x7D

Command Length: 8

Format description: no parameter

Command example: 7B 00 08 01 A5 42 F0 7D

Return format: 0x7B XX X 0xA5 0x42 XX X 0x7D

Return length: 10

Format description: 2 bytes 1 parameter, the parameter is the hexadecimal value of I_{sc} , the value is the decimalized value of the data

Return command example: 7B 00 0A 01 A5 42 00 50 42 7D

Return command description: The set I_{sc} is 8.0A (assuming 61015-600, the decimal place is in front of the first digit at the beginning of the lower position)

g) Command word: 43H

Command function: Query the set V_{mp} value

Command format: 0x7B XX X 0xA5 0x43 X 0x7D

Command Length: 8

Format description: no parameter

Command example: 7B 00 08 01 A5 43 F1 7D

Return format: 0x7B XX X 0xA5 0x43 XX X 0x7D

Return length: 10

Format specification: 2 bytes 1 parameter, the parameter is the hexadecimal value of V_{mp} , the value is

the decimalized value of the data

Return command example: 7B 00 0A 01 A5 43 0D AC
AC 7D

Return command description: The set V_{mp} is 350.0V
(assuming 61015-600, the decimal place is in front of
the first digit at the beginning of the lower position)

h) Command word: 44H

Command function: Query the set I_{mp} value

Command format: 0x7B XX X 0xA5 0x44 X 0x7D

Command Length: 8

Format description: no parameter

Command example: 7B 00 08 01 A5 44 F2 7D

Return format: 0x7B XX X 0xA5 0x44 XX X 0x7D

Return length: 10

Format description: 2 bytes 1 parameter, the parameter
is the hexadecimal value of I_{mp} , the value is the
decimalized value of the data

Return command example: 7B 00 0A 01 A5 44 00 46 3A
7D

Return command description: The set I_{mp} is 7.0A
(assuming 61015-600, the decimal place is in front of
the first digit at the beginning of the lower position)

(5) Setting class commands (0x5A)

a) Command word: 00H

Command function: Set the voltage value

Command format: 0x7B XX X 0x5A 0x00 XX X 0x7D

Command length: 10

Format description: 2 bytes 1 parameter, the parameter
is the hexadecimal value of the voltage setting value,
the value is the decimalized value of the data

Command example: 7B 00 0A 01 5A 00 0B B8 28 7D

Example description: Set the output voltage to 300.0V

b) Command word: 01H

Command function: Set the current value

Command format: 0x7B XX X 0x5A 0x01 XX X 0x7D

Command length: 10

Format description: 2 bytes 1 parameter, the parameter

is the hexadecimal value of the current setting value, the value is the decimalized value of the data

Command example: 7B 00 0A 01 5A 01 00 EF 55 7D

Example description: Set the output current to 23.9A

c) Command word: 02H

Command function: Set the power value

Command format: 0x7B XX X 0x5A 0x11 XX X 0x7D

Command length: 10

Format specification: 2 bytes 1 parameter, the parameter is the hexadecimal value of the power setting value, the value is the decimalized value of the data

Command example: 7B 00 0A 01 5A 02 00 64 CB 7D

Example: Set the power value to 1.00kW

d) Command word: 40H

Command function: Set SAS data (V_{oc} , I_{sc} , V_{mp} , I_{mp})

Command format: 0x7B XX X 0x5A 0x40 XX XX XX XX X 7D

Command length: 16

Format description: 2 bytes 1 parameter, the parameter is the hexadecimal value of V_{oc} , I_{sc} , V_{mp} , I_{mp} setting value, the value is the decimalized value of the data, note that the data order cannot be changed.

Command example: 7B 00 10 01 5A 40 0F A0 00 50 0D AC 00 46 A9 7D

Example description: Set V_{oc} to 400.0V, I_{sc} to 8.0A, V_{mp} to 350.0V, I_{mp} to 7.0A.

e) Command word: 51H

Command function: Set the serial number of the storage group

Command format: 0x7B XX X 0x5A 0x51 XX X 0x7D

Command length: 10

Format description: 2 bytes 1 parameter,

Command example: 7B 00 0A 01 5A 51 00 02 B8 7D

Command description: The current step number is set to 2

f) Command word: 52H

Command function: Set the voltage of the storage group
Command format: 0x7B XX X 0x5A 0x52 XX X 0x7D
Command length: 10
Format description: 2 bytes 1 parameter,
Command example: 7B 00 0A 01 5A 52 09 C4 84 7D
Command description: The current step voltage is set to 250.0V

g) Command word: 53H

Command function: Set the current of the storage group
Command format: 0x7B XX X 0x5A 0x53 XX X 0x7D
Command length: 10
Format description: 2 bytes 1 parameter,
Command example: 7B 00 0A 01 5A 53 00 C4 7C 7D
Command description: The current step current is set to 19.6A

h) Command word: 54H

Command function: Set the power value of the storage group
Command format: 0x7B XX X 0x5A 0x54 XX X 0x7D
Command length: 10
Format description: 2 bytes 1 parameter,
Command example: 7B 00 0A 01 5A 54 00 64 86 7D
Command description: The current step time is set to 1.00kW

(6) Sequence test setting class commands (0x5C)

a) Command word 01H

Command function: Select sequence
Command format: 0x7B XX X 0x5B 0x04XX X 0x7D
Command Length: 9
Format description: 1 byte 1 parameter, (0-49)
Command example: 7B 00 09 01 5C 01 01 68 7D
Command description: Read sequence 1, i.e., set the current sequence to TEST1

b) Command word 03H

Command function: Define the function of the selected step, this command has more parameters

Command format: 0x7B XX X 0x5C 0x03 XXXXX 0x7D

Command length: varies with different modes

Format description: The first byte is the step number (0-21), the second byte is the mode: 0: NOP, 1: VIMode, 2: Ramp V, 3: Ramp I, 4: CP, 5: Repeat, 6: SubCall, 7: Return, 8: Loop, 9: Next, 10: Stop, 11: Goto, 12: Pause, when the selected mode is 0 (NOP), 5 (Repeat), 7 (Return), 9 (Next), 10 (Stop) or 12 (Pause), the total number of parameters is 2, i.e., only the step number and mode need to be set, and the corresponding mode has no parameters. When the selected mode is 6 (SubCall), 8 (Loop) or 11 (Goto), the total number of parameters is 3. In addition to the step number and mode, it is also necessary to set the parameters corresponding to the mode: the subsequence number of the recall, the number of loops, and the sequence number of the Goto jump, respectively. When the selected mode is 2 (RampV), 3 (RampI), 4 (CPMode), the total number of parameters is 8. Except for the step number and mode, it is necessary to set OVP, Vi, Vf, current value, execution time (S, ms), and when the selected mode is 1, the total number of parameters is 7. Except for the step number and mode, it is necessary to set OVP, V, I, execution time (S, ms).

The specific command format and parameters are shown in the following table:

X (step)	X Mode	XX	XX	XX	XX	XXX	XX
Step number	0	*	*	*	*	*	*
Step number	1	OVP	Voltage value	Current value	*	Time S	Time ms
Step number	2	OVP	Voltage starting value	Voltage end value	Current value	Time S	Time ms
Step number	3	OVP	Current starting value	Current end value	Current value	Time S	Time ms
Step number	4	OVP	Voltage limit	Current limit	Power value	Time S	Time ms
Step number	5	*	*	*	*	*	*
Step number	6	Serial number (0-49)	*	*	*	*	*
Step number	7	*	*	*	*	*	*
Step number	8	Number of loops (0-65535)	*	*	*	*	*
Step number	9	*	*	*	*	*	*
Step number	10	*	*	*	*	*	*
Step number	11	Serial number (0-49)	*	*	*	*	*

Step number	12	*	*	*	*	*	*
-------------	----	---	---	---	---	---	---

In the above table: * stands for no such parameter, each X represents a byte command example:

7B 00 0A 01 5C 03 00 00 6A 7D Set step 0 to NOP

7B 00 15 01 5C 03 01 01 03 E8 00 64 00 64 0F FF FF 00 FF 36 7D Set step 1 to VI mode

7B 00 17 01 5C 03 02 02 03 E8 03 64 00 64 00 64 00 FF FF 00 09 9C 7D Set step 2 to RAMPV mode

7B 00 17 01 5C 03 03 03 03 E8 03 64 00 64 00 64 00 FF FF 00 09 9E 7D Set step 3 to RAMPI mode

7B 00 17 01 5C 03 04 04 03 E8 00 64 00 64 00 01 00 FF FF 00 09 3A 7D Set step 4 to CP mode

7B 00 0A 01 5C 03 05 05 74 7D Set step 5 to Repeat mode

7B 00 0C 01 5C 03 06 06 00 16 8E 7D Set step 6 to SubCall

7B 00 0A 01 5C 03 07 07 78 7D Set step 7 to Return

7B 00 0C 01 5C 03 08 08 FF FF 7A 7D Set step 8 to Loop

7B 00 0A 01 5C 03 09 09 7C 7D Set step 9 to Next

7B 00 0A 01 5C 03 0A 0A 7E 7D Set step 10 to Stop

7B 00 0C 01 5C 03 0B 0B 00 16 98 7D Set step 11 to Goto 7B

00 0A 01 5C 03 0C 0C 82 7D Set step 12 to Pause

c) Command word 04H

Command function: Save the current sequence

Command format: 0x7B XX X 0x5C 0x04 X 0x7D

Command length: 8

Format description: None

Command example: 7B 00 08 01 5C 04 69 7D

d) Command word 05H

Command function: Delete the current sequence

Command format: 0x7B XX X 0x5C 0x05 X 0x7D

Command length: 8

Format description: None

Command Example: 7B 00 08 01 5C 05 6A 7D

e) Command word 07H

Command function: Start sequence test

Command format: 0x7B XX X 0x5C 0x07 X 0x7D

Command length: 8
Format description: None
Command example: 7B 00 08 01 5C 07 6C 7D

f) Command word 08H

Command function: Stop sequence test
Command format: 0x7B XX X 0x5C 0x08 X 0x7D
Command length: 8
Format description: None
Command example: 7B 00 08 01 5C 08 6D 7D

g) Command word 09H

Command function: Pause sequence test
Command format: 0x7B XX X 0x5C 0x09 X 0x7D
Command length: 8
Format description: None
Command example: 7B 00 08 01 5C 09 6E 7D

h) Command word 0AH

Command function: Continue sequence test
Command format: 0x7B XX X 0x5C 0x0A X 0x7D
Command length: 8
Format description: None
Command example: 7B 00 08 01 5C 0A 6F 7D

(7) Sequence test query class commands (0xC5)

a) Command word 00H

Command function: Query the current serial number
Command format: 0x7B XX X 0xC5 0x00 X 0x7D
Command length: 8
Format description: None
Command example: 7B 00 08 01 C5 00 CE 7D

b) Command word 01H

Command function: Query the current sequence test

status

Command format: 0x7B XX X 0xC5 0x01 X 0x7D

Command length: 8

Format description: none

Command example: 7B 00 08 01 C5 01 CF 7D

(0: sequence test completed, 1: running, 2: paused)

5.4 Communication Protocol General Return Command Description

The general return data frame format for the lower computer is as follows:

Frame header	Total bytes	Slave address	Order			Checksum	End of frame
			Type	Command Word	Parameter		
0x7B	XX	X	X	X	X	X	0x7D

The frame header, total bytes, slave address, checksum, and frame tail have the same meaning as the received data frame format.

- a) Command type: When the correct command is received, it is the command type of the received communication command. The command type is 0x99 when an error command is received.
- b) Command word: the received command word.
- c) Parameter:
 1. When the correct query class or a combined class command that needs to return data is received, the parameter of reply command should be the query result, and the number of bytes is specified according to the specific command.
 2. When an incorrect command reply is received, the parameter here should be an error code, and the number of bytes is 1 byte. The slave should return an error message to the master each time it receives a command error from the master.
 3. Returns the previously received command type and command word when a command of a type other than a query class or a combined class command that needs to return data is correctly received, where the parameter is 0x00.

Error Code	Error message	Remark
0x01	Checksum error	

0x02	Command type error	Command type is not in the scope of communication protocol
0x03	Command word error	When the command word is not in the scope of the communication protocol
0x04	Status discrepancy	This error code is answered when the current state does not allow the received command to be executed. For example, if the power supply does not allow changing the overcurrent protection limit in the startup state, the power supply should reply to the error code if the command to change the overcurrent protection limit is received at the start-up time
0x05	Parameter error	Invalid or inconsistent parameters
0x06	Protection alarm	For example, when overcurrent protection occurs in the power supply, the upper computer sends
		Send the command to set the output voltage of the power supply, and the power supply should respond to the error code
0x07	Out of range	The measured parameter is out of the current range
0x08	Command length error (i.e., the length of the communication command input is different from the theoretical length of the command)	

Chapter 6 DC Test Power Supply SCPI Protocol

6.1 Basic Command

- (1) Clear alarm messages

*CLS

This command is used to clear the alarm information

Command syntax: *CLS

Parameters: None

- (2) Reset factory settings

*RST

This command resets the power supply to the factory set state.

Command syntax: *RST

Parameters: None

6.2 Query Measured Value

- (1) Query the voltage output value

MEASure:VOLTage[:DC]?

This command is used to read the latest power supply voltage DC value.

Command syntax: MEASure:VOLTage[:DC]?

Parameters: None

Return parameter: <NRf>

Return parameter unit: V

Example: MEASure:VOLTage?

- (2) Query the current output value

MEASure:CURRent[:DC]?

This command is used to read the latest power supply current DC value.

Command syntax: MEASure:CURRent[:DC]?

Parameters: None

Return parameter: <NRf>

Return parameter unit: A

Example: MEASure: CURRent?

- (3) Query the power output value

MEASure:POWer[:DC]?

This command is used to read the output power of the latest power supply.

Command syntax: MEASure[:SCALar]:POWer[:DC]?

Parameters: None

Return parameter: <NRf>

Return parameter unit: kW

Example: MEASure:POWer?

- (4) Query voltage, current, and power output value

MEASure?

This command is used to get the latest measured values (voltage, current, power).

Return parameter unit: V, A, kW

Command syntax: MEASure?

Return parameter: <NRf>, <NRf>, <NRf>

6.3 Query and Set Output Setting Value

- (1) Query and set the output voltage value

[SOURce:]VOLTage

This command is used to set the power supply voltage value.

Command syntax: [SOURce:]VOLTage <NRf>

Parameters: NRf

Unit: V

Reset value: 0.0

Example: SOURce:VOLTage 60.0

Query command: [SOURce:]VOLTage?

Return parameter: NRf

- (2) Query and set the output current value

[SOURce:]CURRent

This command is used to set the power supply current value.

Command syntax: [SOURce:]CURRent <NRf>

Parameters: NRf

Unit: A

Reset value: 0.0

Example: SOURce:CURRent 2.0

Query command: SOURce:CURRent?

Return parameter: NRf

(3) Query and set the output power value

[SOURce:] POWer

This command is used to set the power output of the power supply.

Command syntax: [SOURce:]POWer < NRf>

Parameters: NRf

Unit: kW

Reset value: 0.0

Example: [SOURce:]POWer 1.0

Query command: [SOURce:]POWer?

Return parameter: NRf

(4) Set the power output state

[SOURce:] OUTPut

This command is used to control the power output to turn on or off.

Command syntax: [SOURce:]OUTPut <bool>

Parameters: 0|1|OFF|ON

Reset value: 0

Example: SOURce:OUTPut 1

Query command: [SOURce:]OUTPut?

Return parameter: 0|1

(5) Set the minimum voltage value of the power supply

[SOURce:]VOLTage:MINimum

This command is used to set the minimum voltage value of the power supply.

Command syntax: [SOURce:]VOLTage:MINimum <NRf>

Parameters: NRf

Unit: V

Reset value: MINimum

Example: [SOURce:]VOLTage:MINimum 2.0

Query command: [SOURce:]VOLTage:MINimum?

Return parameter: NRf

(6) Set the maximum voltage value of the power supply

[SOURce:]VOLTage:MAXimum

This command is used to set the maximum voltage value of the power supply.

Command syntax: [SOURce:]VOLTage:MAXimum <NRf>

Parameters: NRf

Unit: V

Reset value: MAXimum

Example: [SOURce:]VOLTage:MAXimum 24.0

Query command: [SOURce:]VOLTage:MAXimum?

Return parameter: NRf

- (7) Set the minimum current value of the power supply

[SOURce:]CURRent:MINimum

This command is used to set the minimum current value of the power supply.

Command syntax: [SOURce:]CURRent:MINimum <NRf>

Parameters: NRf

Unit: A

Reset value: 0.0

Example: [SOURce:]CURRent:MINimum 0.0

Query command: [SOURce:]CURRent:MINimum?

Return parameter: NRf

- (8) Set the maximum current value of the power supply

[SOURce:]CURRent:MAXimum

This command is used to set the maximum current value of the power supply.

Command syntax: [SOURce:]CURRent:MAXimum <NRf>

Parameters: NRf

Unit: A

Reset value: MAXimum

Example: [SOURce:]CURRent:MAXimum 120.0

Query command: [SOURce:]CURRent:MAXimum?

Return parameter: NRf

- (9) Set the minimum power value of the power supply

[SOURce:]POWer:MINimum

This command is used to set the minimum power of the power supply.

Command syntax: [SOURce:]POWer:MINimum <NRf>

Parameters: NRf

Unit: kW

Reset value: 0.00

Example: [SOURce:]POWer:MINimum 0.00

Query command: [SOURce:]POWer:MINimum?

Return parameter: NRf

(10) Set the maximum power value of the power supply

[SOURce:]POWer:MAXimum

This command is used to set the maximum power of the power supply.

Command syntax: [SOURce:]POWer:MAXimum <NRf>

Parameters: NRf

Unit: kW

Reset value: MAXimum

Example: [SOURce:]POWer:MAXimum 1.00

Query command: [SOURce:]POWer:MAXimum?

Return parameter: NRf

(11) Set the power supply voltage rise time

[SOURce:]VOLTage:RISE

This command is used to set the power supply voltage rise time.

Command syntax: [SOURce:]VOLTage:RISE < NRf>

Parameters: NRf

Unit: S

Example: [SOURce:]VOLTage:RISE 5.0

Query command: [SOURce:]VOLTage:RISE?

Return parameter: NRf

(12) Set the power supply voltage fall time

[SOURce:]VOLTage:FALL

This command is used to set the power supply voltage fall time.

Command syntax: [SOURce:]VOLTage:FALL < NRf>

Parameters: NRf

Unit: S

Reset value: 0.0

Example: [SOURce:]VOLTage:FALL 2.0

Query command: [SOURce:]VOLTage:FALL?

Return value: NRf

(13) Set the power supply current rise time

[SOURce:]CURRent:RISE

This command is used to set the power supply current rise time.

Command syntax: [SOURce:]CURRent:RISE < NRf>

Parameters: NRf

Unit: S

Reset value: 0.0

Example: [SOURce:]CURRent:RISE 10.0

Query command: [SOURce:]CURRent:RISE?

Return parameter: NRf

(14) Set the power supply current fall time

[SOURce:]CURRent:FALL

This command is used to set the power supply current fall time.

Command syntax: [SOURce:]CURRent:FALL <NRf>

Parameters: NRf

Unit: S

Reset value: 0.0

Example: [SOURce:]CURRent:FALL 2.0

Query command: [SOURce:]CURRent:FALL?

Return parameter: NRf

(15) Set the power supply power rise time

[SOURce:]POWer:RISE

This command is used to set the power rise time of the power supply.

Command syntax: [SOURce:]POWer:RISE <NRf>

Parameters: NRf

Unit: S

Example: [SOURce:]POWer:RISE 5.0

Query command: [SOURce:]POWer:RISE?

Return parameter: NRf

(16) Set the power supply power fall time

[SOURce:] POWer: FALL

This command is used to set the power fall time of the power supply

Command syntax: [SOURce:]POWer:FALL <NRf>
Parameters: NRf
Unit: S
Reset value: 0.0
Example: [SOURce:]POWer:FALL 3.0
Query command: [SOURce:]POWer:FALL?
Return parameters: NRf 4,

6.4 PV Command

(1) Set VOC value

SOLar:EDIT:SAS:VOC

This command is used to set VOC.

Command syntax: SOLar:EDIT:SAS:VOC < NRf>

Parameters: NRf

Unit: V

Example: SOL:EDIT:SAS:VOC 2.0

Query command: SOLar:EDIT:SAS:VOC?

Return parameter: NRf

(2) Set ISC value

SOLar:EDIT:SAS:ISC

This command is used to set ISC.

Command syntax: SOLar:EDIT:SAS:ISC < NRf>

Parameters: NRf

Unit: A

Example: SOL:EDIT:SAS:ISC 2.0

Query command: SOLar:EDIT:SAS:ISC?

Return parameter: NRf

(3) Set VMP value

SOLar:EDIT:SAS:VMP

This command is used to set VMP.

Command syntax: SOLar:EDIT:SAS:VMP < NRf>

Parameters: NRf

Unit: V

Example: SOL:EDIT:SAS:VMP 5.0

Query command: SOLar:EDIT:SAS:VMP?

Return parameter: NRf

(4) Set IMP value

SOLar:EDIT:SAS:IMP

This command is used to set IMP.

Command syntax: SOLar:EDIT:SAS:IMP < NRf>

Parameters: NRf

Unit: A

Example: SOL:EDIT:SAS:IMP 5.0

Query command: SOLar:EDIT:SAS:IMP?

Return parameter: NRf

Chapter 7 Warranty

Warranty period: The warranty period is twelve months from the date of shipment from the company for those who use the instrument purchased from the company, and from the date of shipment from the operating department for those who purchase from the operating department. The warranty should be issued to the instrument warranty card. During the warranty period, if the instrument is damaged due to improper operation by the user, the repair cost shall be borne by the user. The instrument is responsible for the lifetime maintenance by the company.

The repair of this instrument requires professional and technical personnel for maintenance; please do not replace the internal components of the instrument without permission during the repair; after the repair of the instrument, it needs to be remeasured and calibrated to avoid affecting the test accuracy. Due to the user's blind repair, replacement of instrument parts caused by damage to the instrument is not covered by the warranty, the user should bear the maintenance costs.

Chapter 8 Appendix

8.1 Version History

This manual will be continuously improved for ease of use.

Due to the possible errors or omissions in the manual, the improvement and perfection of instrument functions, the update of technology and the upgrade of software, the manual will be adjusted and revised accordingly.

Please pay attention to the software version and manual version you are using.

⚠ Disclaimer: Our company may improve and enhance the performance, functions, software, structure, appearance, accessories, packaging and manuals of this product without prior notice! If this causes any doubt, please contact our company.



同惠网址

常州同惠电子股份有限公司 📞 **400-624-1118**

地址：江苏省常州市新北区天山路3号(213022)

电话：0519-85132222 传真：0519-85109972

[Http://www.tonghui.com.cn](http://www.tonghui.com.cn) Email: sales@tonghui.com.cn